

REVIEW ALL INSTRUCTIONS COMPLETELY BEFORE ATTEMPTING INSTALLATION**GENERAL NOTES:**

- Instructions are intended for trained door systems technicians using proper tools and equipment.



WARNING! – Components under **extreme spring tension** can cause death or serious injury.



WARNING! – **Releasing the door operator brake, or loosening or removing any part of the drive system, can cause the door to move uncontrolled** and cause death or serious injury.

- The terms “door” and “doors” apply generally to all types of rolling closures. If an instruction refers to a specific type, it will be noted as such.
- Instructions refer to doors operated from the left side (tension adjusting wheel on the right side).
- Wall bolts are not provided. Refer to the “WALL BOLT SCHEDULE” for suggested wall bolts. Wall construction and wall bolts must be adequate for the size and weight of door and its intended use.

INSTALLATION:

NOTE: If the door is to be mounted between the jambs, it is provided with extra “filler” angle(s) or tube(s). Install the filler(s) as shown in the installation drawings, following the same procedure as for the installation of wall angles for face mount doors as noted below.

NOTE: If the door is tube mount, no wall angles are provided – guides and brackets attach directly to the tube supports. Install the tubes following a similar procedure as for the installation of the wall angles. Tube support mounting clips/plates must be adequately attached to the tubes, the slab and the supporting structure. Tube supports may also require additional bracing.

NOTE: If a fascia is provided, evaluate field conditions and decide when the best time would be to install it. The fascia may attach to separate fascia mounting angles installed on each jamb or directly to the filler angles or tubes. If intermediate support(s) are included, space support(s) equally between the jambs. Drill holes as indicated on the “WALL BOLT SCHEDULE” and attach support(s) to the header. Attach the fascia with the sheet metal screws provided.

- 1) Measure the door opening and verify that the door size is correct for the opening. If it is not correct, contact the factory for further instruction.

- 2) **If the door is face mount:** Level across the opening and mark the “heels” dimension on the jambs as shown on the “DOOR SCHEDULE”. (For a door installed with a “Z” guide configuration, “heels” is the same as the door width plus the width of both guides. For a door installed with an “E” guide configuration, “heels” is the same as the door width plus the width of both guides and the thickness of both wall angles.)

If the door is tube mount: Level across the opening and mark the “tube to tube” dimension on the floor as shown on the “DOOR SCHEDULE”.

- 3) Set the wall angles/tubes on the floor/sill at the “heels” or “tube to tube” marks. Wall angles/tubes must be installed level and plumb. Shim up the lower wall angle/tube, if necessary, to be level.

- 4) *(Omit this step if the door is tube mount)* Using the wall angles as templates, mark, or drill through slots, for wall bolts.

- Drill holes as indicated on the “WALL BOLT SCHEDULE” for the wall bolt type used.
- Locate all holes at the center of the slots in the wall angles.

- 5) **If the door is face mount:** Secure the wall angles to the jambs. All wall bolts require a washer between the bolt head and the wall angle.

If the door is tube mount: Attach mounting clips/plates to the tubes and secure to the slab and the supporting structure. Tubes may also require additional bracing.

- 6) Slide the brackets onto the barrel shafts.

- The tension bracket (plate with tension lock) goes on the end of the barrel with the rotating shaft that is normally notched or drilled to match the type of tension adjusting wheel provided.
- The operating bracket (with operating mechanism) goes on the opposite end of the barrel with the fixed shaft that is normally keyed.
- The end of the barrel should be tight against the bearing in the operating bracket.
- There should be clearance between the barrel and the tension bracket.

- 7) It is recommended that operating bracket components be assembled now. Operating bracket components must be set tight against the outside of the bracket bearing. Use washers to shim for alignment if necessary. *(As an alternative, this may be done after the barrel and brackets are raised and bolted to the wall angles.)*

NOTE: Assembly details are included for typical push-up, chain, crank and motor operated doors. *For motor operated doors, refer to supplemental installation instructions provided with the motor operator.*

- 8) Remove the truss head bolts and washers from across the barrel. Raise the barrel and brackets into position between the tops of the wall angles/tubes. **CAUTION:** *Use a hoisting method adequate to safely lift the size and weight of the barrel.* Bolt the brackets to the inside of the wall angles/tubes with the flat head bolts, washers and hex nuts provided.

9) Raise the curtain, with the starter slats pointing away from the wall, to below the barrel.
CAUTION: Use a hoisting method adequate to safely lift the size and weight of the curtain.
Set slings around the barrel and the curtain. **CAUTION: Use a minimum of 2 slings spaced across the barrel, but as many as required to safely support the size and weight of the curtain.**
Set the curtain into the slings and cut the bands around the curtain. Unroll enough of the curtain to reach the barrel. Feed the curtain between the back of the barrel and the slings. Turn the barrel to bring the curtain over the top and around to the front. Center the curtain between the brackets. Align the slots in the starter slats with the nuts welded to the barrel. The starter slat at each side of the curtain must be against the endlock. Attach the starter slats to the barrel with the truss head bolts and washers previously removed.

10) Slide the tension adjusting wheel onto the shaft extending through the tension bracket. If the shaft is drilled or keyed to secure the tension adjusting wheel, install the pin or key provided (and tighten any set screws).

11) Insert a winding bar into the top of the tension adjusting wheel and pull down, away from the wall, to wind the spring assembly. Carefully continue adding tension until the curtain coils itself nearly completely around the barrel. When the curtain is hanging balanced, lock the tension wheel with the tension lock bolt.



WARNING! – Components under **extreme spring tension** can cause death or serious injury.

12) Attach the guide channels to the insides of the wall angles/tubes with truss head bolts. If attaching to wall angels, use washers under the flange nuts.

13) Make sure the curtain stops are in position and secured to the guides. Adjust the spring tension so the bottom bar wants to raise up to the curtain stops. Remove the slings from around the curtain and barrel. Try the operation of the door and adjust spring tension as necessary so the curtain is as balanced as possible. **CAUTION: Adjust spring tension only when the curtain is in the open position.**



WARNING! – Components under **extreme spring tension** can cause death or serious injury.

14) If intermediate hood support(s) are provided, install now. Space support(s) equally between the brackets. The top of the support(s) must be even with the top of the brackets. Drill holes as indicated on the “WALL BOLT SCHEDULE” for the wall bolt type used and attach supports.

15) Align the brackets so they are square (not “toed in” or “toed out”). If a hood is provided, lift the hood, set in place centered between the brackets, and attach to the band on each bracket (and intermediate supports) with sheet metal screws provided.

16) If the door is motor operated and a momentary pressure close function is desired, or the door cannot be seen from any control station, at least one monitored sensing device is required. Install devices as shown, connect to the operator, and test to make sure all devices function correctly.

17) If end cap(s) or a motor cover is provided, install them now.

18) Make sure warning labels are attached to the door as follows:

- L70011 Guide Label is attached to the guide (or to the wall if the guides are concealed) at eye level on the operating side of the door
- L70010 Spring Label is attached to the tension bracket
- L70027 Operator Label is attached to the operating bracket (this label is not provided if the door is push-up operated)

If any warning labels are missing or not legible, contact the factory for replacement labels.

WALL BOLT SCHEDULE

CONSTRUCTION	WIDTH	TYPE	SIZE	SIZE	HOLE DEPTH
Concrete	to 16'	Wedge anchor	3/8" x 3"	3/8"	2 1/4"
	over 16'	Wedge anchor	1/2" x 4"	1/2"	3"
Filled CMU, brick or concrete	to 16'	Sleeve anchor	1/2" x 3"	1/2"	3"
	over 16'	Sleeve anchor	5/8" x 4"	5/8"	4"
Drywall/16 ga. metal stud	to 16'	Self-tapping screw	3/8" x 2"	5/16"	N/A
	over 16'	Not Recommended	N/A	N/A	N/A
Drywall/wood stud	to 16'	Lag screw	3/8" x 3"	1/4"	N/A
	over 16'	Lag screw	1/2" x 4"	11/32"	N/A
3/16" (min.) structural steel	to 16'	Self-tapping screw	3/8" x 1"	Letter "S"	N/A
	over 16'	Machine screw	1/2" x 1"	27/64"	N/A

GENERAL NOTES:

- 1) Length of wall bolts is generally referenced from the bottom of the head, except for wedge anchors which are referenced by overall length.
- 2) Length of wall bolts must be increased accordingly if the door is attached to the jambs through another material (such as drywall, veneer, stucco, plaster, tile, etc.) depending on the thickness of that material.

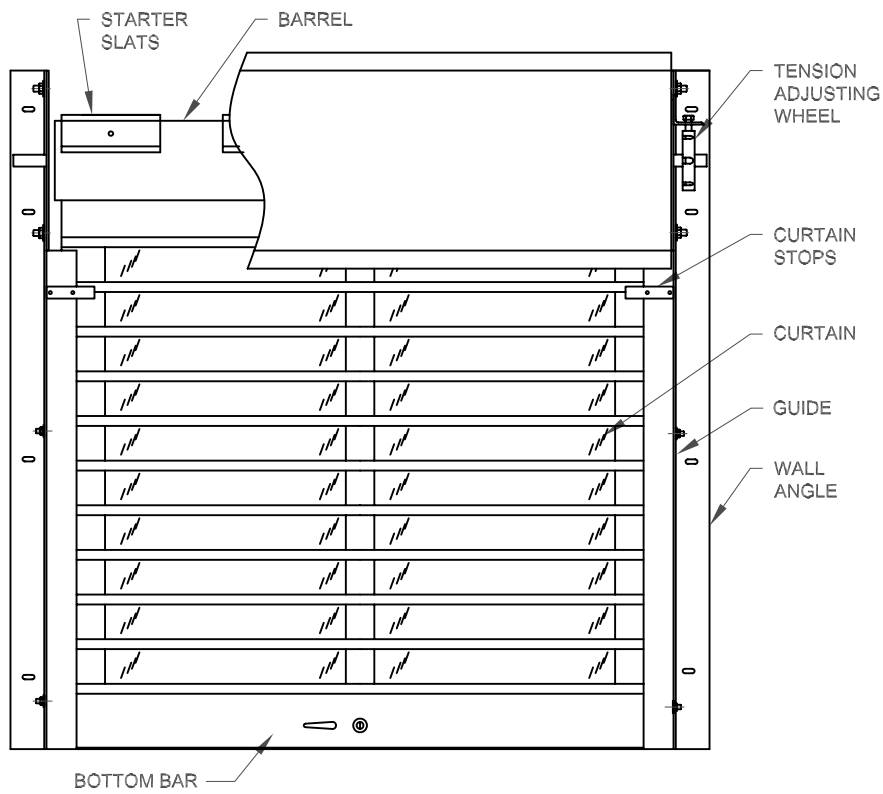

FACE MOUNT

NOTE: MODEL AC "CLEAR PANEL" SHOWN - OTHER MODELS SIMILAR

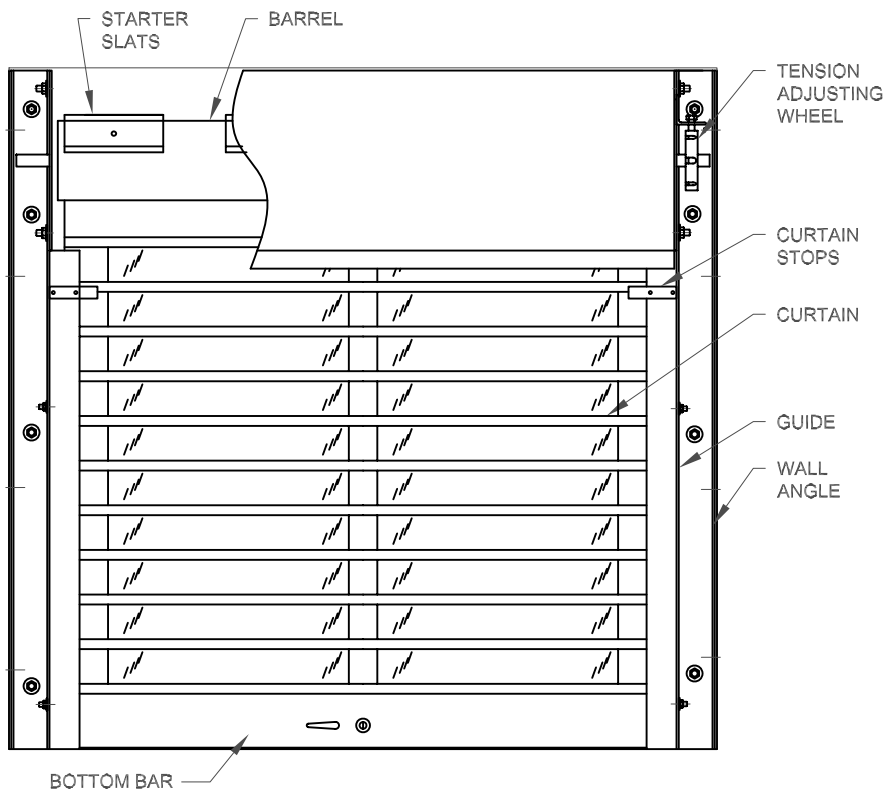
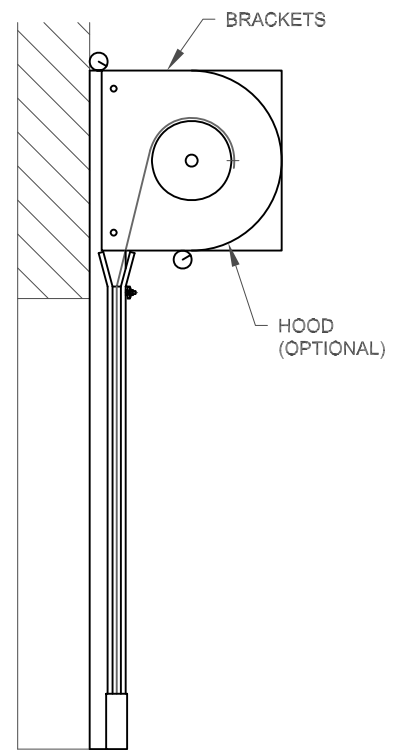

BETWEEN JAMB MOUNT

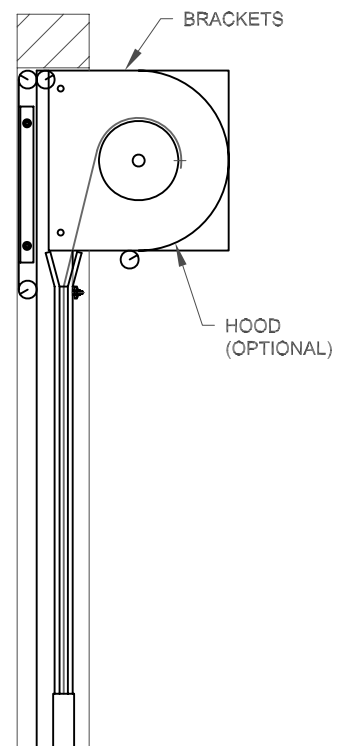

GENERAL NOTE:
DOOR WIDTHS MAY NOT BE
THE SAME AS OP'NG WIDTHS

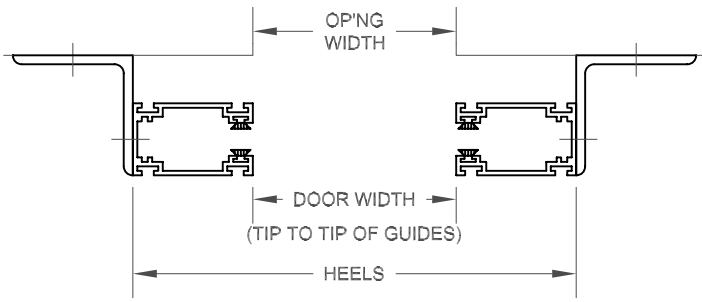

"Z" GUIDE CONFIGURATION

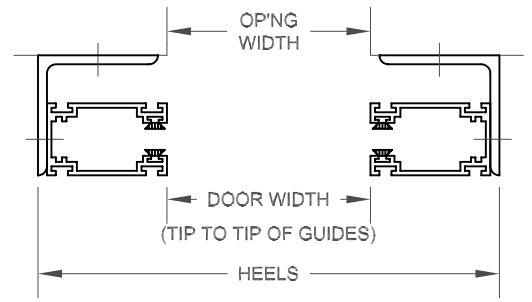

"E" GUIDE CONFIGURATION

FACE MOUNT

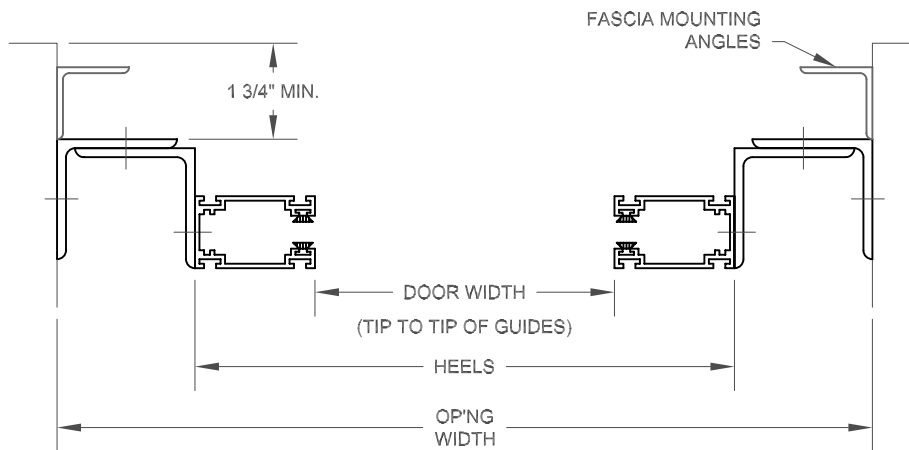

BETWEEN JAMB MOUNT

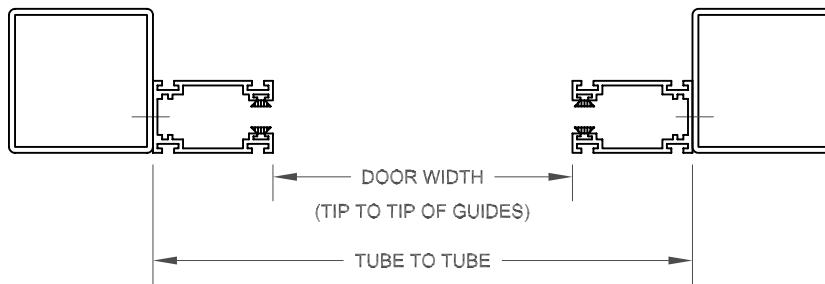

TUBE MOUNT

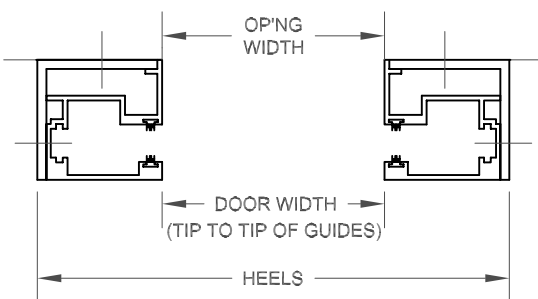

FACE MOUNT

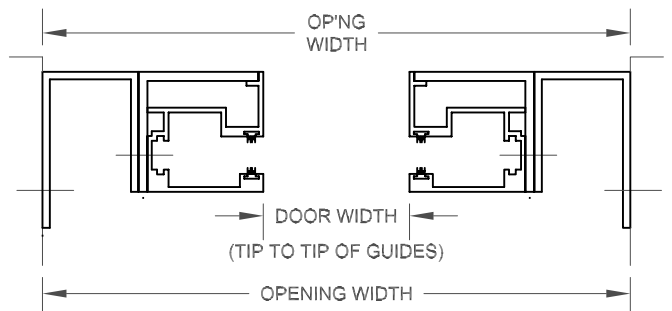

BETWEEN JAMB MOUNT

"CD" GUIDE

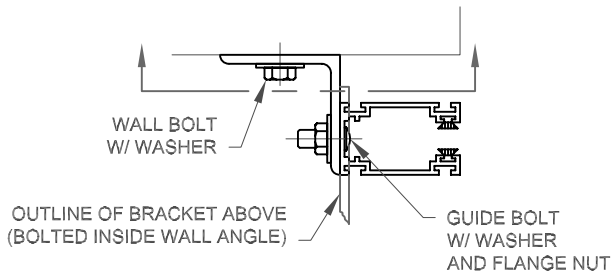

**STANDARD MOUNT
(Z-CONFIG. SHOWN))**

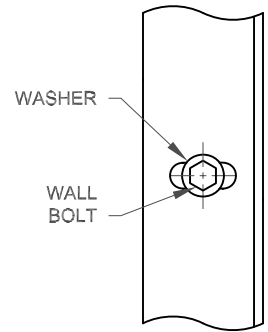

SECTION

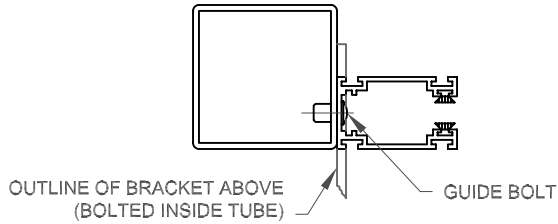

**TUBE MOUNT
(OPTIONAL)**

GUIDE INSTALLATION & ASSEMBLY

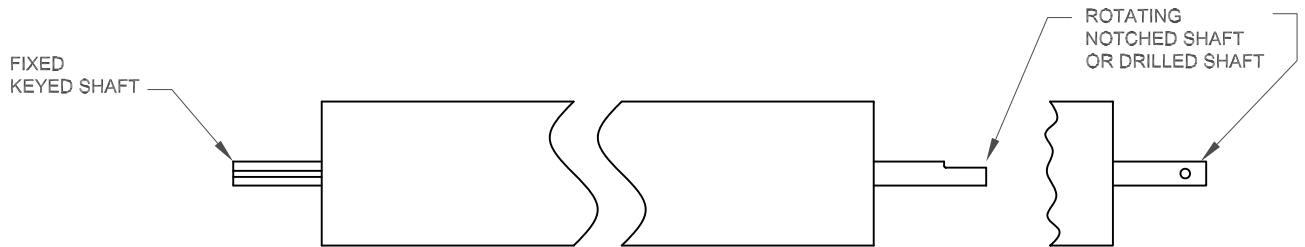

LEFT HAND OPERATION IS SHOWN-
RIGHT HAND OPERATION IS OPPOSITE

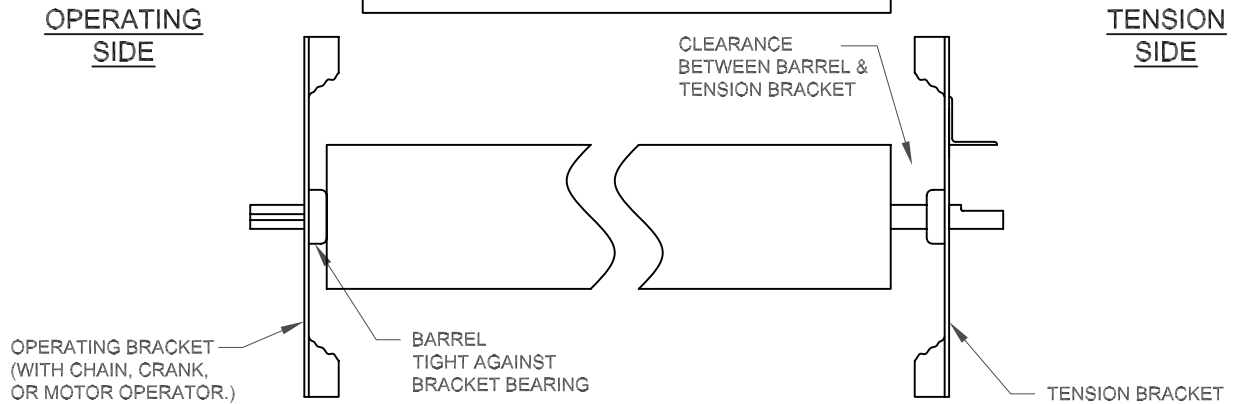

BARREL & BRACKET ASSEMBLY

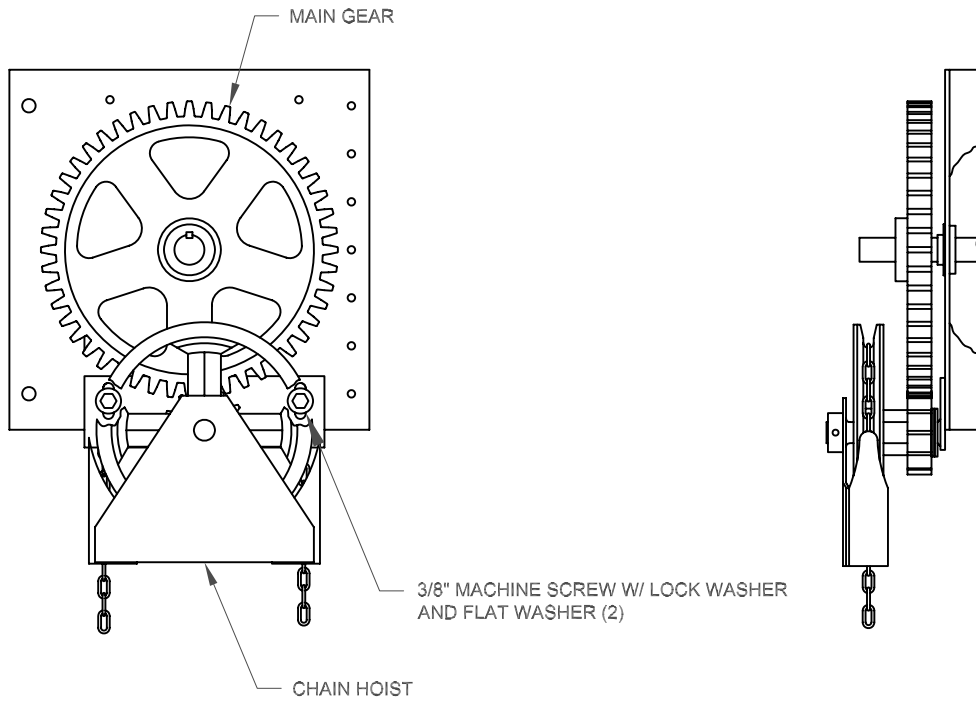

CHAIN OPERATOR WITH SINGLE GEAR REDUCTION

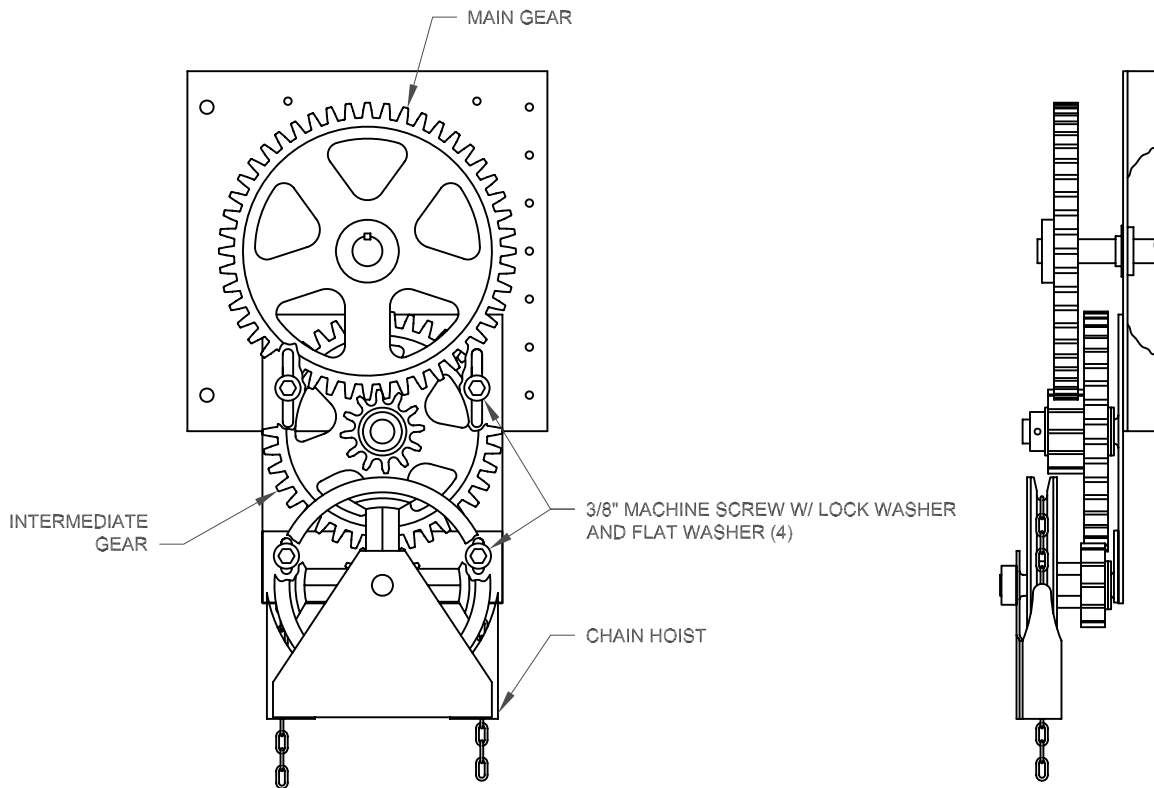

CHAIN OPERATOR WITH MULTIPLE GEAR REDUCTION

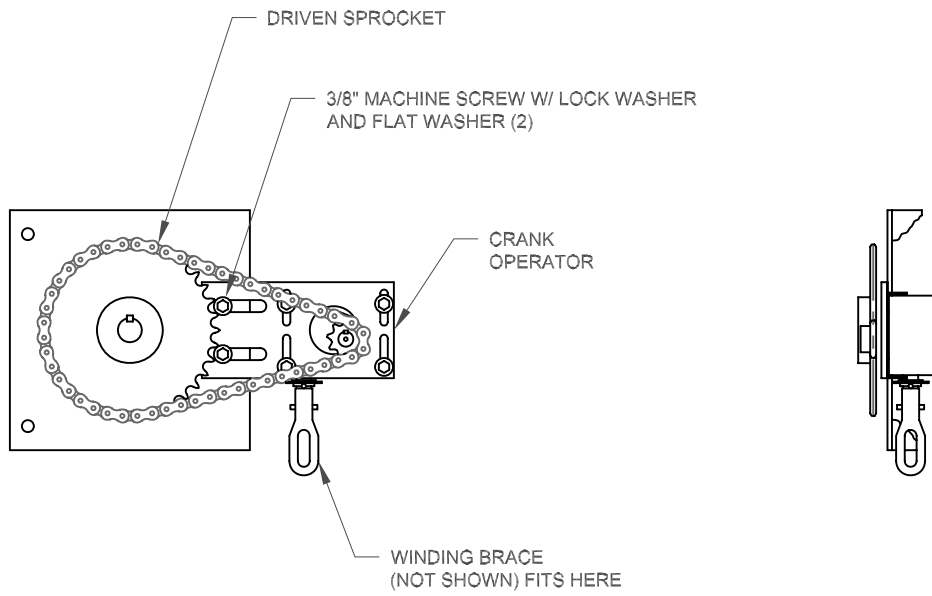

CRANK OPERATOR WITH REDUCTION SPROCKETS

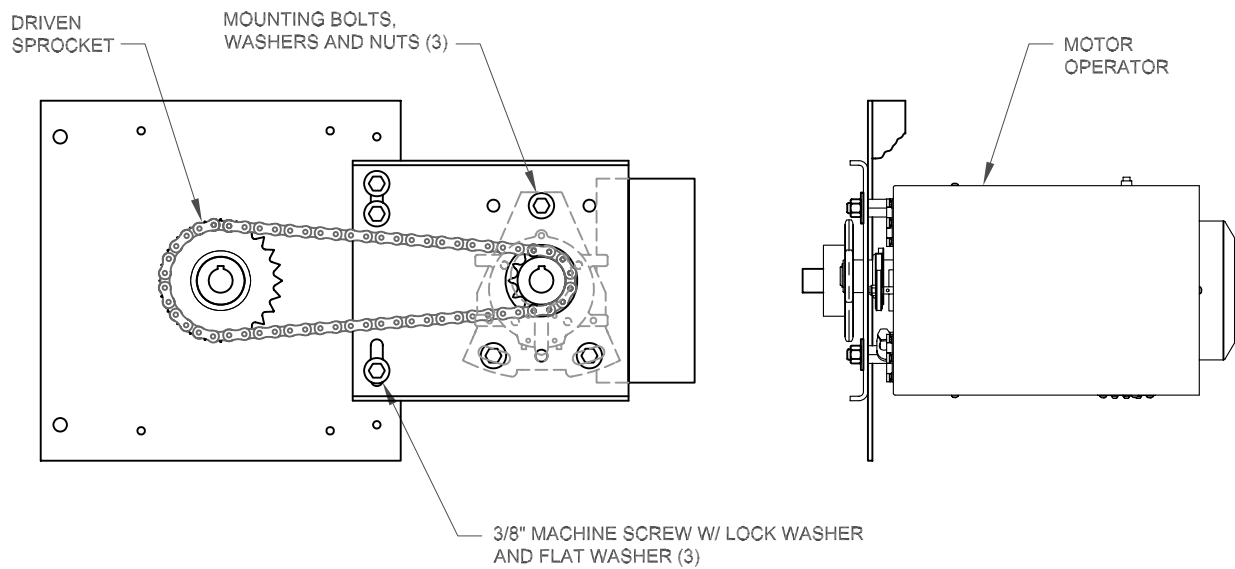

MOTOR OPERATOR WITH STRAIGHT MOUNTING PLATE
(MGRL SHOWN - MGRL-H AND MGH SIMILAR)

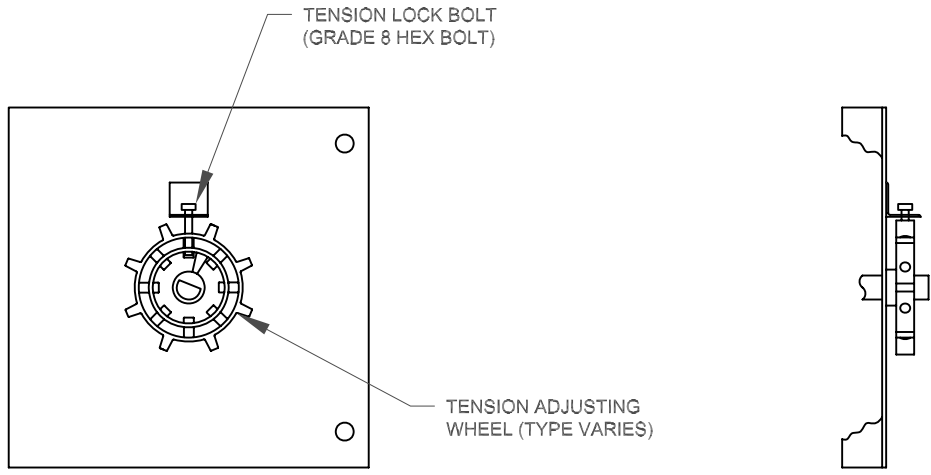

NOTE - TENSION LOCK BOLTS
ARE GOLD IN COLOR WITH SIX
INDICATOR MARKS ON THE HEAD



STANDARD TENSION BRACKET