



Fire Door Release
MODEL AR-D2

MANUAL RESET ALARM RELEASE – V3

INSTRUCTION MANUAL

GENERAL INFORMATION

1. Review all installation instructions, procedures, cautions and warnings contained within this manual and on the release device prior to installing and/or servicing this product. As with all release device systems, maximum fire protection is provided when installed in accordance with factory specifications and used with fusible link systems.
2. DO NOT install this unit without fusible links.
3. Installation and testing to factory specifications shall be performed by a trained door systems technician for proper operation in accordance with all of the latest National Fire Protection Association (NFPA), Underwriters Laboratories (UL), National Electrical Code (NEC), local, state, county, district and/or other applicable building and fire standards, guidelines, regulations and codes including, but not limited to, all appendices and amendments and the requirements of the local authority having jurisdiction (AHJ).

GENERAL WARNINGS

1. High voltage can cause death or serious injury.
 - Turn off power to release before servicing.
 - Only open hinged front panel to service.
2. Fire door could close rapidly without warning and cause serious injury or death.
 - Keep doorway clear when testing or servicing release.
 - Tampering with release may cause fire door to close without warning.
 - Turning off power to release will cause fire door to close. (This unit has an internal battery that may still be charged and holding the door from releasing even in the event of a loss of power.)

SYSTEM DESCRIPTION

This release device is a failsafe constantly energized solenoid mechanism. It is designed for use on rolling fire doors and single or bi-parting sliding fire doors with level or inclined tracks. Inside the device, contact relays receive the alarm signal from the detector(s) or fire alarm control panel. When the device receives the signal, the power to the solenoid is cut, releasing the latch and causing the fire door to close. The alarm signal must be a Form C dry contact. Any interruption of line power longer than the duration of battery power will release the solenoid mechanism. The release has a 10 second delay upon power failure and alarm, closed door detection capabilities, Form C relay outputs for release status and 24VDC output power for warning prior to/during door closing.

SPECIFICATIONS

Input Power Rating:	100-240VAC, 0.5A; 24VAC, 1.0A; 24VDC, 0.6A
Alarm Dry Contact Rating:	12.2 ohms max line impedance
Lower Limit Microswitch Rating:	12.2 ohms max line impedance
Door Close Warning Power:	24VDC @Max. 0.5A
Status Dry Contact:	Rating: 24VDC/VAC, 0.5A Max. Resistive Load
Frequency:	50Hz or 60Hz
Release Pull:	50 lbs (22.7kgs)
Fuse:	F1 & F2: 2A@250V, Fast-Act Type

*Input voltage [standby/full load** current]: 100~240VAC [0.15~0.1A/0.5~0.25A], 24VAC [0.5/1.0A] or 24VDC [0.2/0.6A]

**Full load current only required for optional warning device(s).

- Release device must be installed with UL Listed fusible links.
- 100-240V input power can be from any source including normal building current.
- 24V input power can be either 24VAC or 24VDC from any source or 24VDC from a fire alarm control panel (FACP) or an approved UL1481 regulated power supply.
- 18-gauge wire recommended.
- For “Indoor Dry” location use only.
- Power for the door closing warning device is provided from when the alarm occurs until the door reaches the close limit, up to a maximum of 1 minute. (48 ft. maximum wire length).
- Use warning device(s) supplied or other compatible device(s).

NOTE: Door Closing Warning Output is only functional when release device has specified input/backup power.

INSTALLATION

Installation Tip: Try this unit before installing it. Test and learn the release mechanism before connecting to a fire door.



Disconnect power supply before servicing.

- For “Indoor Dry” location use only. All wiring must satisfy the most current version of NFPA72 – National Fire Alarm Code and the National Electric Code.
1. Standard mounting of release device is on a vertical surface with release latch exiting right side of enclosure. Unit may be rotated 90° clockwise for bottom pull or 180° for left side pull (test button and LED’s will be on top), or mounted on ceiling.

2. Structure supporting release device (and eye bolts) must be adequate to support its weight and the load pulling on the release latch (and eye bolts).
3. Use suitable fasteners for mounting conditions, such as
 - expansion or sleeve anchors into concrete
 - sleeve anchors into masonry
 - self-tapping screws into steel framing
 - lag screws into wood framing

On drywall construction, it may be necessary to bridge across studs with a suitable support system – DO NOT use hollow wall anchors

4. Illustrations for typical installation configurations are following - actual configurations may differ depending upon field conditions and designs of fire door closing systems.
5. Fusible link cable must pull straight out of release device a sufficient distance to allow for complete release of fire door closing mechanism(s). For most closing systems, a straight pull for 18 inches before turning is adequate. Some systems may require more, others may not require as much. See door manufacturer recommendations and NFPA 80 for use of this product with specific door types. DO NOT install this unit without fusible links.

NOTE: Use as few turns as possible – avoid turns greater than 90°.

6. Installation and testing is to be performed by a trained door systems technician.

AR-D2 Fire Door Release Assembly

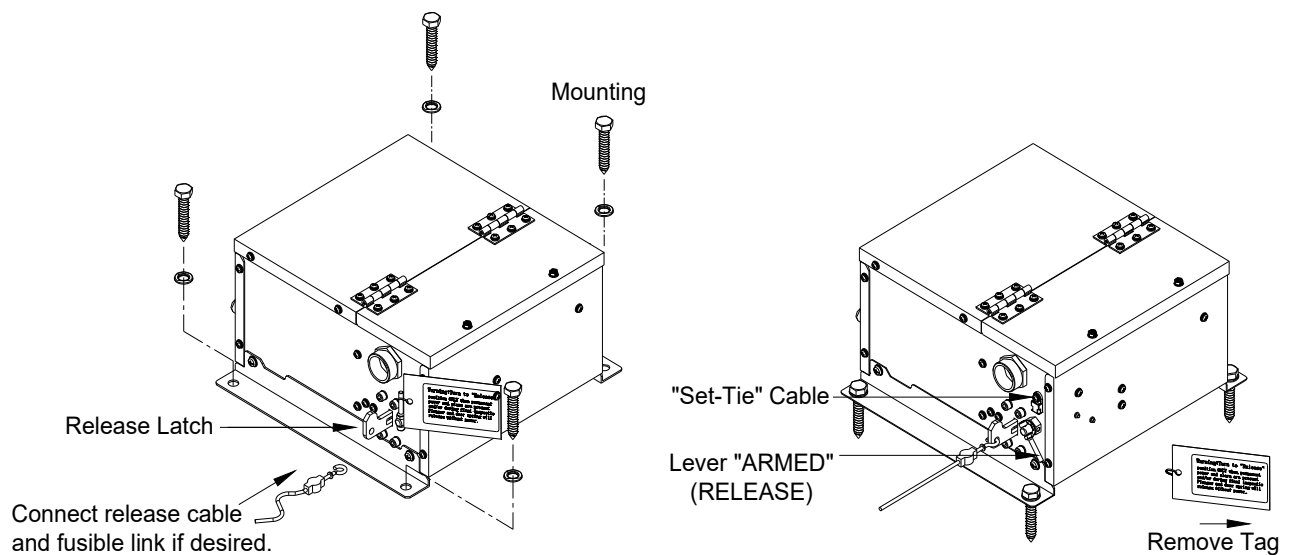

NOTE: Typical configurations are following - actual configurations may differ depending upon field conditions and designs of fire door closing systems. Distance from release latch in side of release device to eye bolt must be adequate to allow for complete release of fire door closing mechanism(s).

“Easy-Reset” chain, crank or motor operation

(LH chain operation shown, RH opposite – crank and motor operation similar)

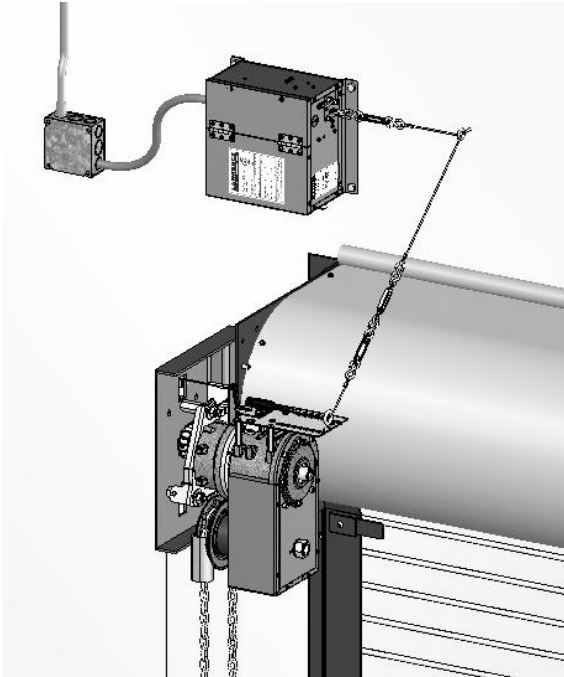

RECOMMENDED INSTALLATION:

Locate eye bolt in wall aligned above eye at end of operator’s fusible link release module and at least 12” above top of door coil. Mount release device at side of door and above top of door coil so release latch in side of release device is level with eye bolt in wall. Install cable from fusible link on fusible link release module through eye bolt in wall to fusible link on release latch.

Push-up operation with single-side tension release

(LH operation shown, RH opposite – other operation methods or single drive side release similar)

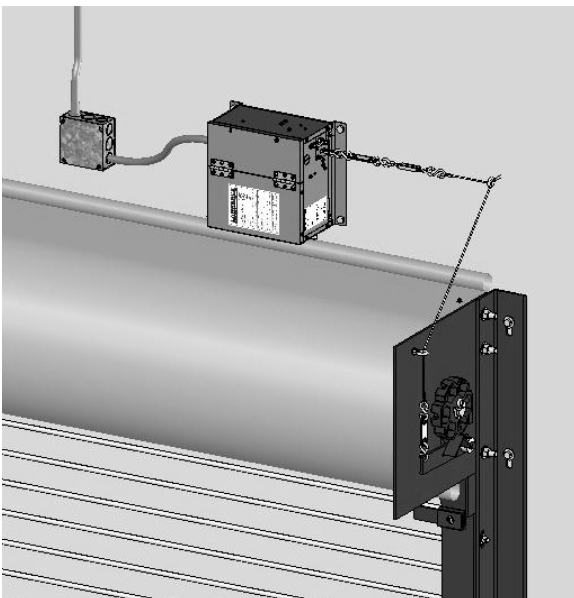

RECOMMENDED INSTALLATION:

Locate eye bolt in wall aligned above eye on bracket plate (or end of drop-out arm) and at least 12” above top of door coil. Mount release device above top of door coil so release latch in side of release device is level with eye bolt in wall. Install cable from fusible link on tension release arm through eye bolt in bracket plate (or from drop-out arm) through eye bolt in wall to fusible link on release latch.

Double-side gear and tension release
(LH chain operation shown, RH opposite)

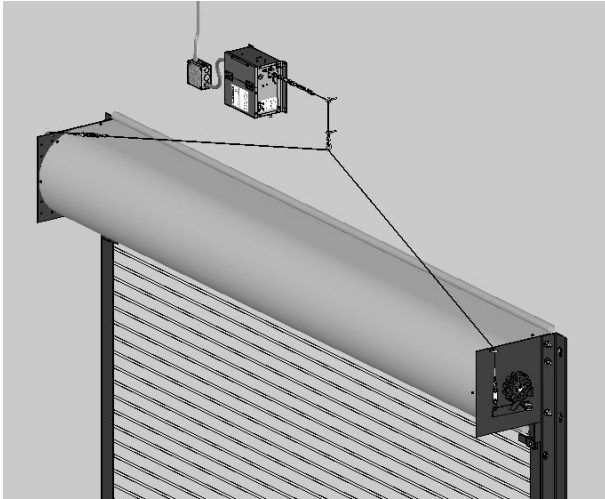

RECOMMENDED INSTALLATION:

Installation requirements will vary depending upon operating and closing system design and type and location of drop-out/release arms. Fusible link cable must pull straight from release latch. Distance from release latch to eye bolt level with latch, and arrangement of remaining fusible link cable(s), must be adequate to allow for complete release of fire door closing mechanisms.

WIRING



Disconnect power supply before servicing.

1. ELECTRICAL CONNECTIONS – Installation of all wiring and connections shall be performed in accordance with, but not limited to, the latest NFPA, UL and NEC standards.
2. Verify voltage rating of power source is compatible with release device.
3. Connect power and alarm signal to the release device using 18 gauge wire.
4. Remove the “Set-Tie” cable after power and alarm connection.

“Set-Tie” cable mechanically secures release latch and must be removed to allow proper emergency operation of release device after installation is completed.

NOTE: A trouble sounder will be activated if power is present, the latch is engaged, but the “Set-Tie” has not been removed and/or the lever is in the “DIS-ARMED” position.



Disconnect power supply before servicing.

WIRE ROUTING

AR-D2

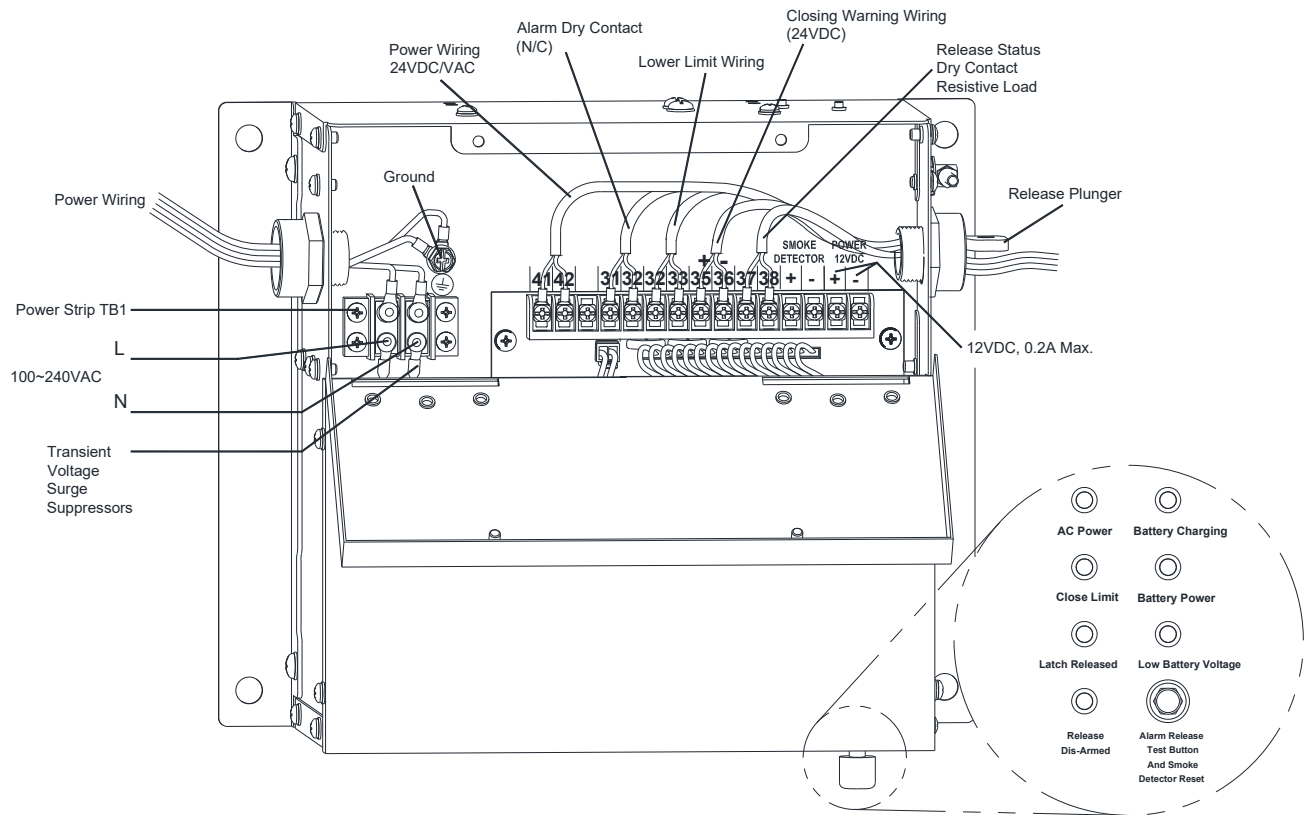

Note: Not supervised.

**100-240VAC Power Input,
Dry Contact Signal from
Alarm Panel**

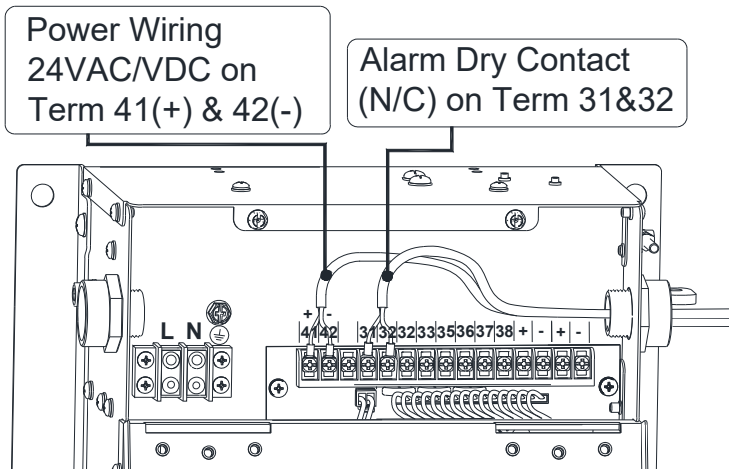
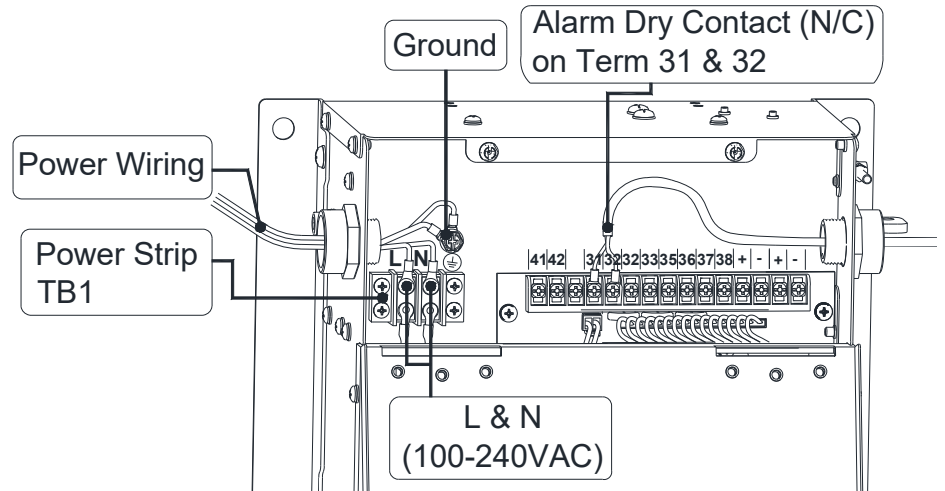

**24VAC/VDC Power Input,
Dry Contact Signal from Alarm Panel**

Lower Limit Detection

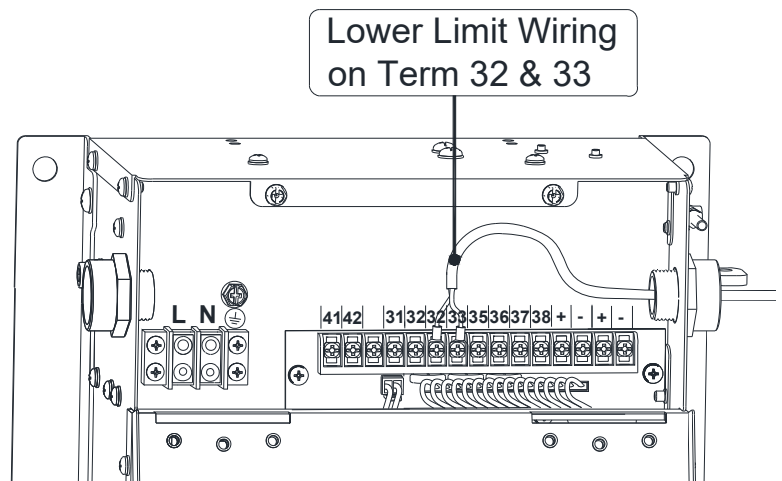

Closing Warning Wiring
on Term 35(+) & 36(-)

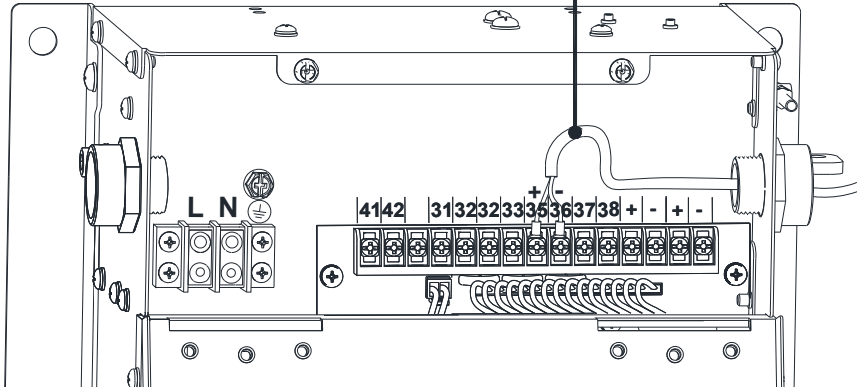

Closing Warning Device

Release Status Dry Contact
Resistive Load on Term 37 & 38

Release Status

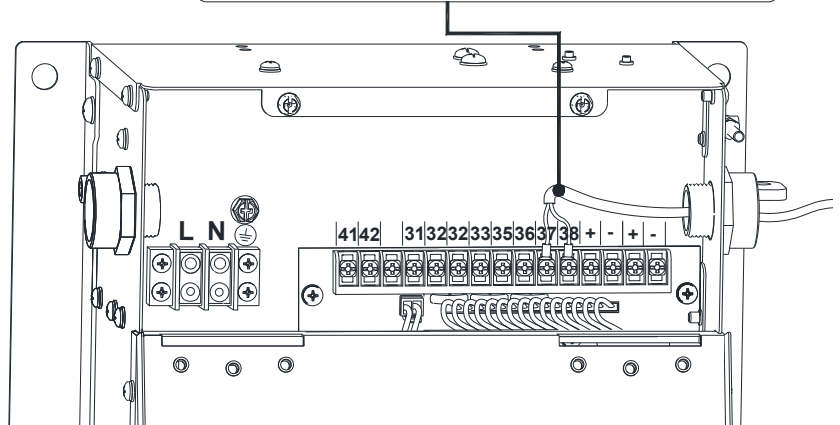

TERMINAL CONNECTIONS



Disconnect power supply before servicing.

TB1

L	N
Input power 100-240VAC*	

See ***Note. 7**

CN2

41	42	31	32	33	35 (+)	36 (-)	37	38	Smoke Detector		Power 12VDC	
									+	-	+	-
Input 24VDC/VAC *Note. 7		Alarm Dry Contact (N/C) Max. Short circuit current 6mA, 14.7VDC *Note 1			Door closing warning 24VDC, 0.5A Max. Regulated *Note 3		Release dry contact *Note 4		Smoke detector connection 12VDC/24VDC, 1.85mA Max. Power-limited, Special application (See Page 15 for connection details) Compatibility ID: SD2W-1 *Note 5		12VDC output power, 0.2A Max. Special Application (See Page 16 for connection details) Compatibility ID: SD4W-1 *Note 6	
			Lower Limit Microswitch (N/C) 3mA, 14.7VDC *Note 2									

* Wirings on CN2 (35,36), Smoke Detector (+, -) and Power 12VDC (+, -) are limited to a distance of 48 feet.

*** Notes:**

1. Terminal 31&32

Building fire alarm panel needs to provide dry contact (N/C) connection with 12.2 ohms max line impedance.

2. Terminal 32&33

Use this connection to notify release device of the status of the door. Field installation of microswitch/proximity sensor on the door or connection to an extra limit switch in the door operator is necessary to use terminal 32&33.

When the door is already in its close position, a closed contact (N/C) can cause the release device not to release (12.2 ohms max line impedance). Power failure will still cause the solenoid to let go, hence resetting is necessary.

3. Terminal 35&36

This connection provides 24VDC, 0.5A power with 18AWG wire for maximum of 48 ft., when release device has been released. This can be used to provide power for warning devices. Power for the warning device is provided from when the alarm occurs until the door reaches the close limit, up to a maximum of 1 minute. The wiring connections are enclosed within conduit or equivalently protected against mechanical injury.

4. Terminal 37&38

These terminal connections will provide the status of this release device. When release device is in the standby mode, connection is open (N/O). When release device have been activated or released, connection would be in closed (N/C) state (12.2 ohms max line impedance).

5. Smoke Detector (+, -)

2-wire 12/24VDC smoke detector connection points. In serial connection max. 4 detectors can be connected.

6. Power 12VDC (+, -)

12VDC output power, 0.2A Max. Up to 4 detectors can be connected, wired in series.

7. See connection chart for power inputs.

Connection Chart

Power Connection Type	AR-D2 Terminals	
	Line In Term: L & N (100-240VAC High Voltage)	Low Voltage Term: 41 & 42 (24VDC or 24VAC)
Alarm Dry Contact Signal	Battery must be good and connected	
	Term: 31&32 Connect FACP* Alarm Dry Contact (12.2 ohms max line impedance)	Term: 31&32 Connect FACP* Alarm Dry Contact (12.2 ohms max line impedance)

* Note: FACP – Fire Alarm Control Panel.

WIRING DIAGRAM

AR-D2 WIRING DIAGRAM
(100~240VAC 1 PHASE or 24VAC/VDC)

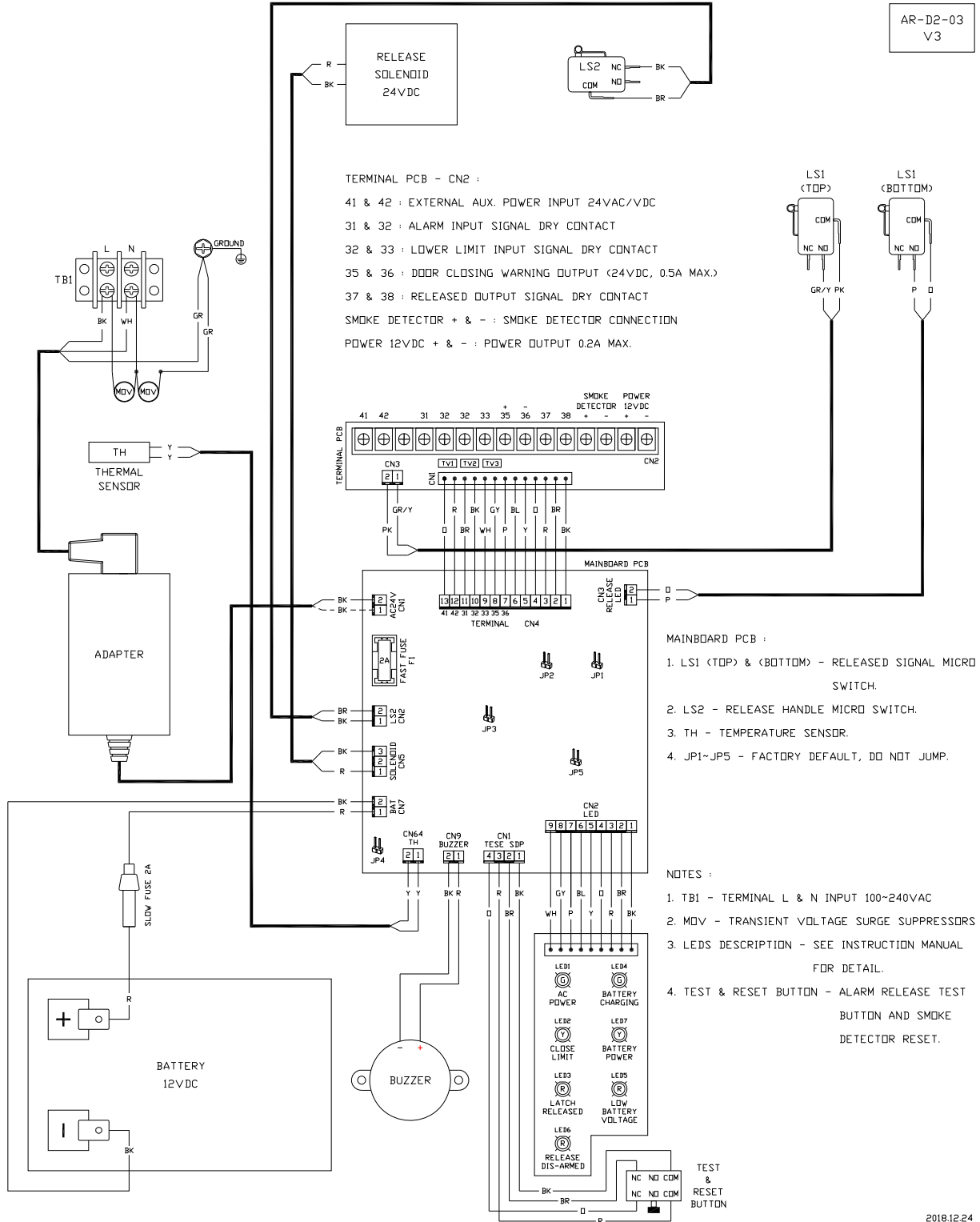

2018.12.24

INDICATOR LIGHTS

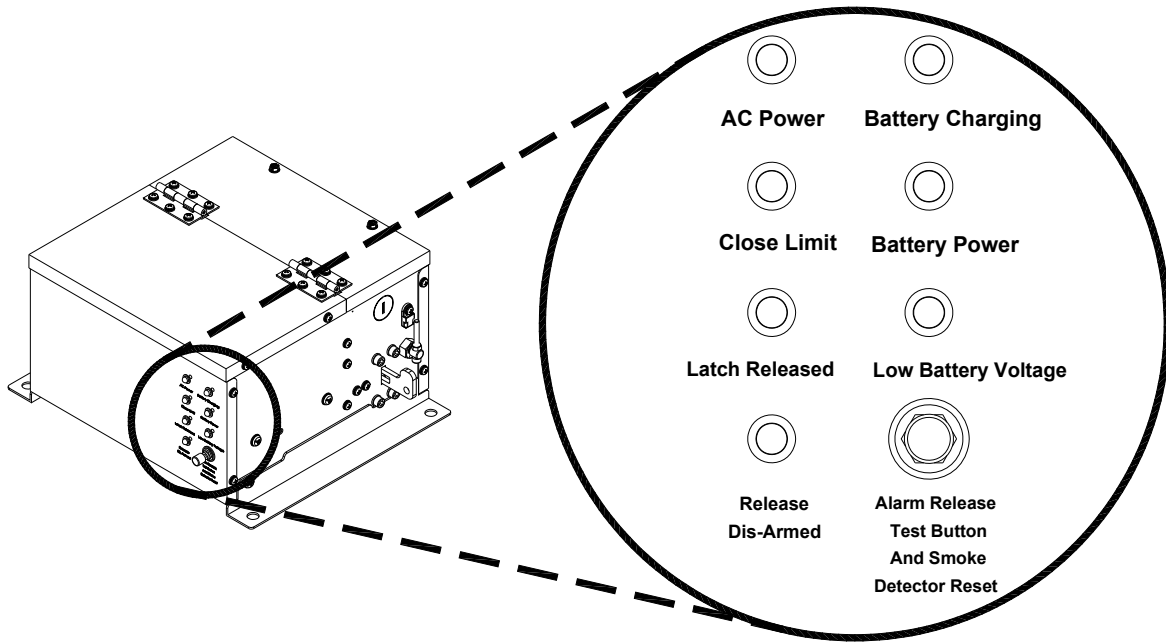

Release Status	Light	Normal	Abnormal
AC Power	Green LED G	Power on	Power off
Battery Charging	Green LED G	Charging	Not Charging
Close Limit	Yellow LED Y	Door Not at Close Limit	Door at Close Limit
Battery Power	Yellow LED Y	Not Being Used	Being Used
Latch Released	Red LED R	Not Released	Released
Low Battery Voltage	Red LED R	Voltage Normal	Low Battery Voltage
Release Dis-Armed	Red LED R	Armed	Not Armed

BATTERY SPECIFICATION & CONNECTION

Specification:

Type	Battery Rating	Battery Expected Standby Operating Time(s)
Sealed Lead Acid Rechargeable Battery	One (1) 12VDC, Max. 12AH	168 Hours



This unit has an internal battery that may still be charged and holding the door from releasing even in the event of a loss of line power.

Connection:

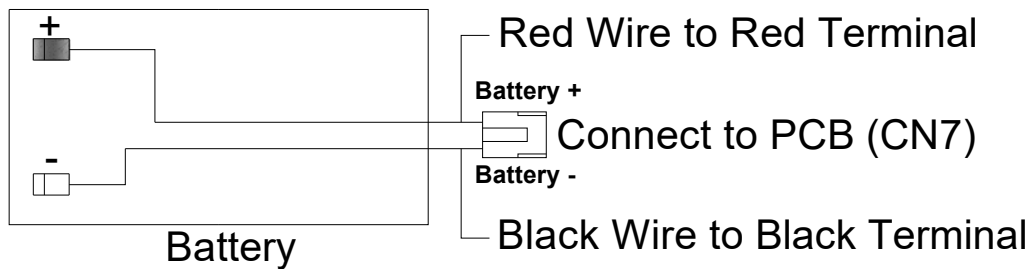

Charging Voltage:	14.7VDC
Charging Current:	Max. 0.55A

- Low battery voltage warning light indication is provided when battery voltage drops below 10VDC.

CONNECTIONS OF INITIATING DEVICES AND ACCESSORIES

Normally Open 2-wire Class B initiating devices:

A maximum of 4 “2-Wire” smoke detectors may be installed with this device.

- Field wiring shall consist of 18 AWG wiring.
- Normally open 2-wire Class B initial devices connected on terminal board CN2 smoke detector (+) & (-), Loop SD2W-1.
- The line impedance should be less than 6 Ohm.
- Keep 2.2k Ohm resistor between CN2 (+) & (-) if smoke detector not used.
- The suitable models of smoke detector for connecting to Loop SD2W-1.

Manufacturer	System Sensor
Model	2W-B, 2WT-B

A 24VDC max. 0.5A door closing warning output signal is provided for annunciator(s) connection at terminal 35,36.

- The suitable models of annunciator for connecting to door closing output warning signal at terminal 35,36.

Manufacturer	System Sensor	U.S. Gear
Model	P2R-P , SR-P	GVMS-S-01

Loop SD2W-1 wiring connections:

AR-D2 SMOKE DETECTOR WIRING DIAGRAM

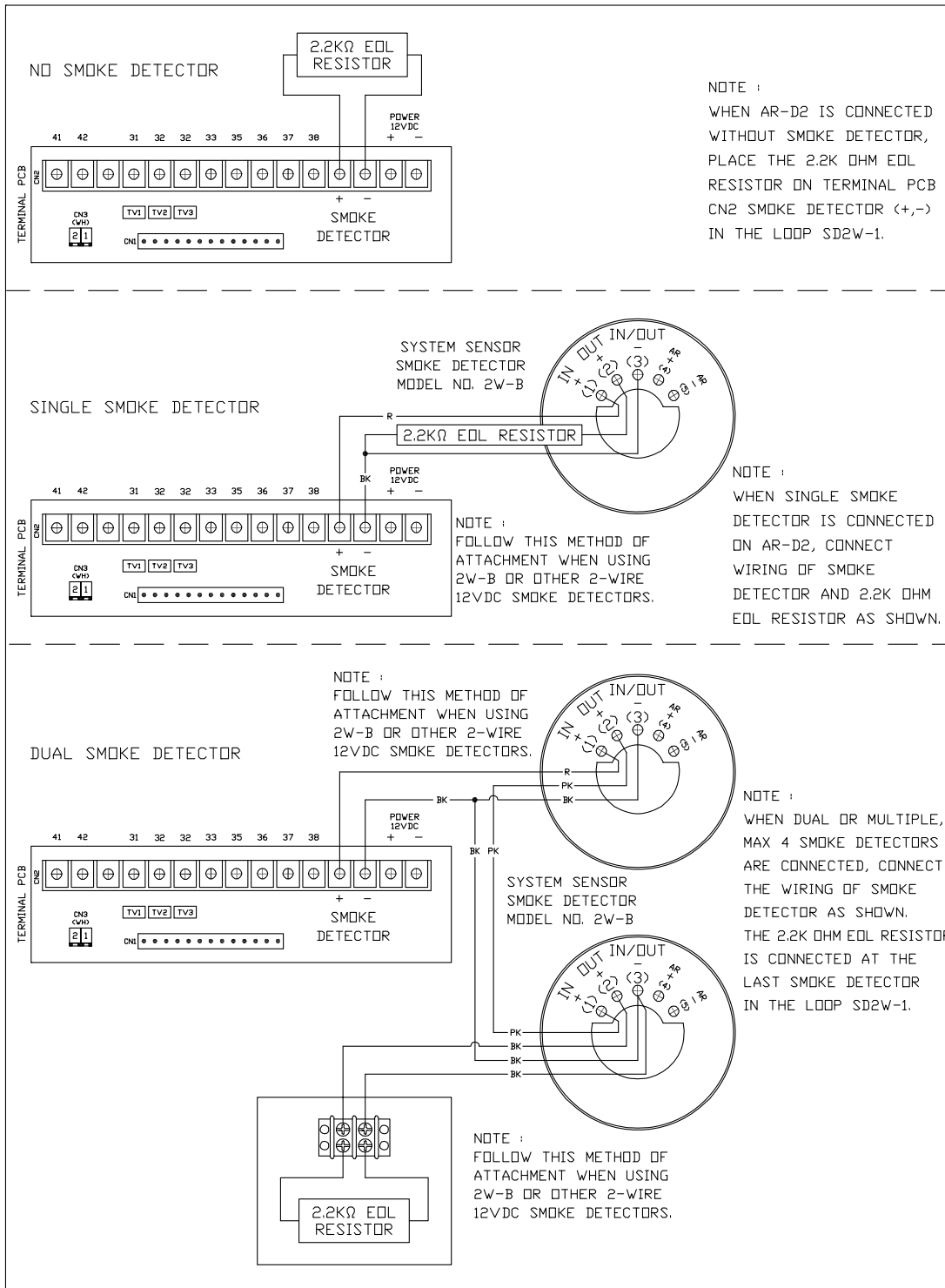

Normally Closed 4-wire Class B initiating devices:

A maximum of 4 “4-Wire” smoke detectors may be installed with this device.

- Field wiring shall consist of 18 AWG wiring.
- When using 4-wire smoke detectors with this device, electrical supervision can be provided by connecting a UL/ULC listed EOL relay.
- Keep 2.2k Ohm resistor between CN2 (+) & (-) if 2-wire smoke detector is not used.
- The suitable models of smoke detector for connecting to Loop SD4W-1.

Manufacturer	System Sensor
Model	4W-B, 4WT-B, 4WTA-B, 4WTR-B, 4WTAR-B, 4WITAR-B, C4W-BA, C4WT-BA, C4WTA-BA, C4WTR-BA, C4WTAR-BA, BEAM1224

- Use one model only for smoke detector circuit connections.

Loop SD4W-1 wiring connections:

NORMALLY CLOSE “ 4-WIRE ” CLASS B INITIATING DEVICE
AR-D2

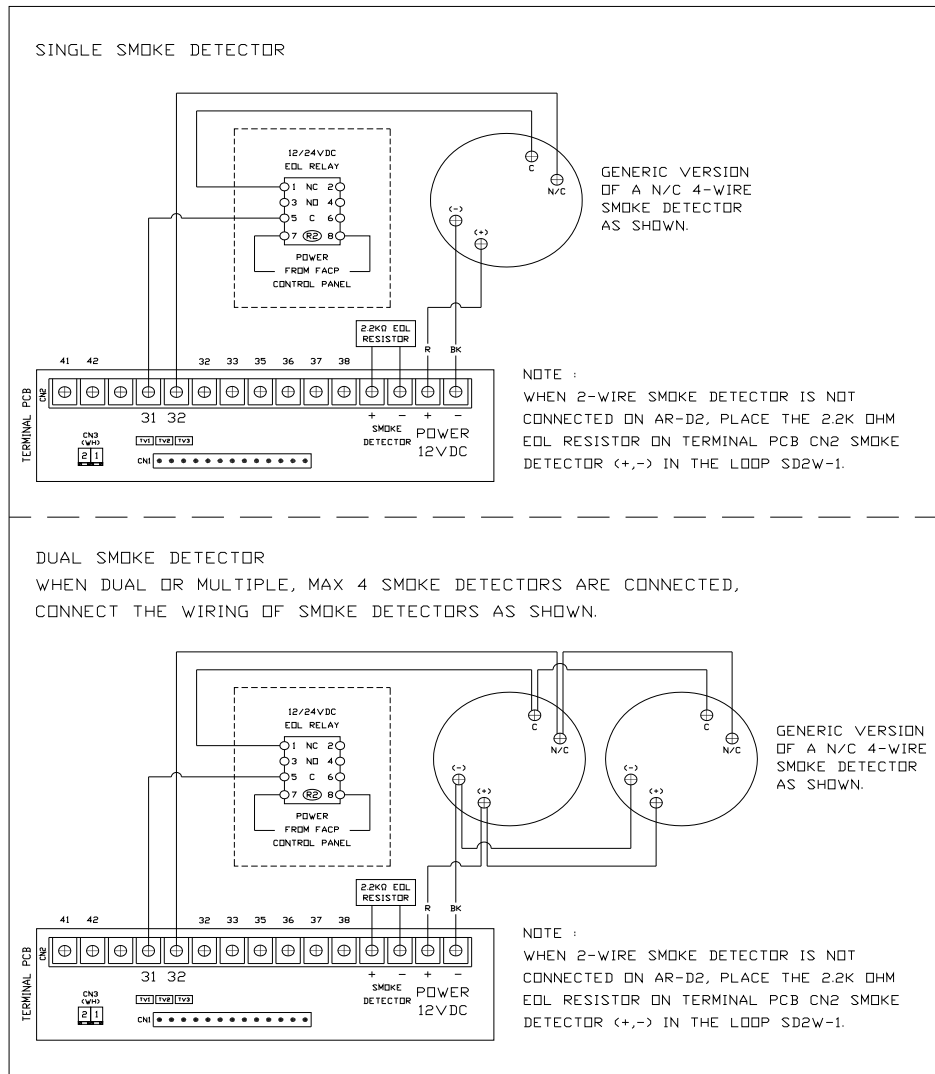

TESTING

1. Simulate alarm condition to verify solenoid disengages, latch releases and fire door closes.
2. Reset and simulate power failure to verify solenoid disengages, latch releases and fire door closes.

RESETTING

1. Make sure power and alarm connection is normal.
2. Push release latch all the way back into slot.
3. Verify solenoid is holding.
4. Verify fusible link cable is properly connected to fire door closing system if used.

NOTE: If power or alarm connection is not normal, solenoid will not hold and release latch will not stay engaged.

MAINTENANCE INSTRUCTIONS



Disconnect power supply before servicing.

Check following items at intervals listed:

CHECK LIST	DESCRIPTION	EVERY 3 MONTHS	EVERY 6 MONTHS	EVERY 12 MONTHS
Fasteners	Check & tighten as required		●	
Drop-test	Inspect door, drop-test for proper operation and full closure per NFPA-80			●
Battery	Check battery voltage (must higher than 11.5VDC)		●	

- ❖ Inspect and service whenever a malfunction either door or release device is observed or suspected.
- ❖ Before servicing, always disconnect power supply to the release device.
- ❖ Replace fuses only with those of the same type and rating.
- ❖ Battery changes every 2 years or fail to charge whichever comes first. The change procedure describe in battery specification and connection.
- ❖ All replacement parts must be obtained from the door manufacturer per NFPA-80.

Testing of the “AR-D2” release device is independent of, and shall in no way be interpreted as an alternative method of, testing of the fire alarm system, and/or any other system component employed on the fire door or counter fire door installation. TESTING SHALL BE PERFORMED AND WITNESSED FOR PROPER OPERATION.