

**"AUTO-RESET" INCREASES HEIGHT OF OPERATORS BY APPROXIMATELY 3"

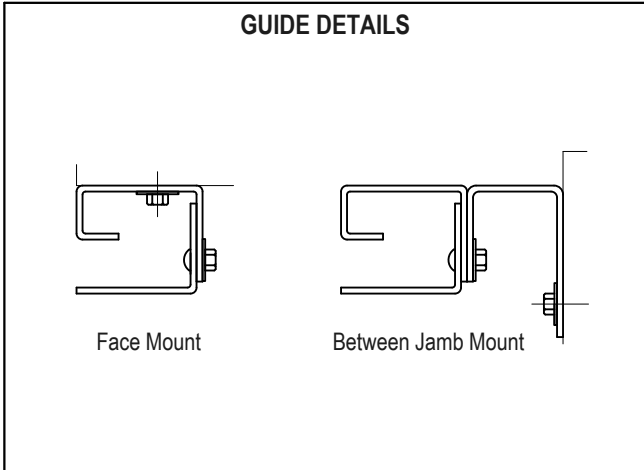

CLEARANCES

Door Width "W"	TS	PS	AS	MS	TA	TM
To 4' #	4 1/4"	4 1/4"	4 1/4"	4 1/4"	4 1/4"	4 1/4"
Over 4' to 7' #	4 5/8"	4 5/8"	4 5/8"	4 5/8"	4 5/8"	4 5/8"
Over 7' to 16'	5 1/8"	5 1/8"	5 1/8"	5 1/8"	5 1/8"	5 1/8"

For face mount to non-masonry jambs with more than 1 layer of drywall,
With 2 layers, add 1/2" to dimensions
With 3 layers, add 1" to dimensions
For face mount to masonry jambs, add 3/4" to dimensions.
#Use the over 7' to 16' clearances for 4-hour rated doors.

"V" (Bracket Size Dimensions - Includes Expansion Clearance)

DOOR HEIGHT	Bottom Bar	T
10'	13"	
8'	12 1/2"	2"
6'	10 1/2"	4"
4'		
2'		
0'		

GENERAL NOTES:
Clearances are based upon standard door construction. Reduced clearances may be available. Some options may require additional clearance. Shop drawings for specific applications are available. Consult factory for any information not shown.

