

*"AUTO-RESET" INCREASES HEIGHT OF CHAIN & CRANK OPERATORS BY APPROXIMATELY 3"

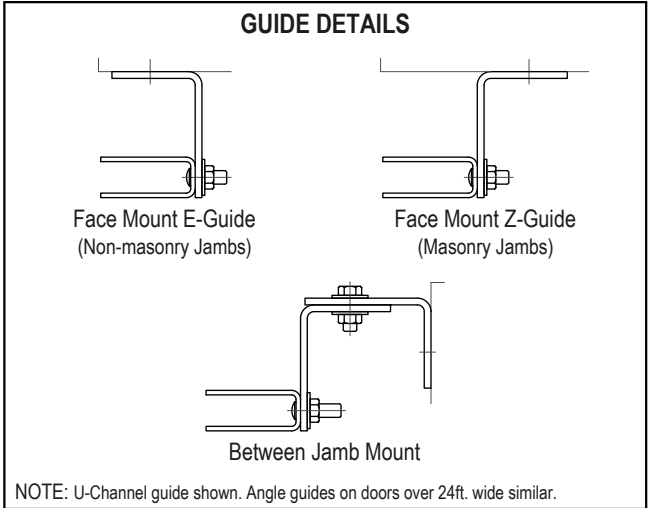

CLEARANCES

Door Width "W"	TS	CS	MS
To 10'	6"	6"	6"
Over 10' to 16'	7"	7"	7"
Over 16' to 20'	8"	8"	8"
Over 20' to 24'	8 1/2"	N/A	8 1/2"
Over 24' to 28'	9 1/2"	N/A	9 1/2"
Over 28' to 30'	10 1/2"	N/A	10 1/2"

For Between Jamb Mount, add 3/4" to dimensions.

DOOR WIDTH	V	T
18"	15 1/2"	3 1/2"
16"	17 1/2"	4 1/2"
14"	18"	4 1/2"
12"	20"	4 1/2"
10"	22"	4 1/2"
8"	25"	6"
6"	28"	6"

GENERAL NOTES:
Clearances are based upon standard door construction. Reduced clearances may be available. Some options may require additional clearance. Drive side shaft may need to be field cut to fit in clearances shown. Shop drawings for specific applications are available. Consult factory for any information not shown.

