

REVIEW ALL INSTRUCTIONS COMPLETELY BEFORE ATTEMPTING INSTALLATION

GENERAL NOTES:

- Instructions are intended for qualified door mechanics using proper tools and equipment.



WARNING! – Components under **extreme spring tension** can cause **SERIOUS INJURY** or **DEATH**.

- The terms “door” and “doors” applies generally to Service Doors, Counter Service Doors and Grilles. If an instruction refers to a specific type, it will be noted as such
- Instructions refer to doors operated from the left side (tension adjusting wheel on the right side).
- Wall bolts are not provided. Refer to “WALL BOLT SCHEDULE” for suggested wall bolts. Wall construction and wall bolts must be adequate for the size and weight of door and its intended use.

INSTALLATION:

- 1) Measure the door opening and verify that the door size is correct for the opening. If it is not correct, contact the factory for further instruction.

NOTE: If a fascia is provided, evaluate field conditions and decide when the best time would be to install it. The fascia may attach to separate fascia mounting angles installed on each jamb or directly to filler tubes or formed shapes. If intermediate support(s) are included, space support(s) equally between the jambs. Drill holes as indicated on the “WALL BOLT SCHEDULE” for the wall bolt type used and attach support(s) to the header. Attach the fascia with the sheet metal screws provided.

NOTE: If the door is to be mounted between the jambs, it is provided with extra “filler” angle(s), tube(s), or formed shape(s). Install the filler(s) as shown in the installation drawings, following the same procedure as for the installation of wall angles as noted below.

NOTE: If a Service Door or Grille is tube mounted, no wall angles are provided - guides and brackets attach directly to the tube supports. Install the tubes following a similar procedure as for the installation of wall angles. Tube support mounting clips/plates must be adequately attached to the tubes, the slab and the supporting structure. Tube supports may also require additional bracing.

- 2) Unbolt and remove guide channels/angles from wall angles. Level across the opening and mark the “heels” dimension on the jambs as shown on the “DOOR SCHEDULE”. (For a door installed with a “Z” guide configuration, “heels” is the same as the door width plus the width of both guides. For a door installed with an “E” guide configuration, “heels” is the same as the door width plus the width of both guides and the thickness of both wall angles.)
- 3) Set the wall angles on the floor/sill at the “heels” mark on each jamb. Wall angles must be installed level and plumb. Shim up the lower wall angle, if necessary, to be level.
- 4) Using the wall angles as templates, mark, or drill through slots, for wall bolts.
 - Drill holes as indicated on the “WALL BOLT SCHEDULE” for the wall bolt type used.
 - Locate all holes at the center of the slots in the wall angles.
- 5) Secure the wall angles to the jambs. All wall bolts require a washer between the bolt head and the wall angle.
- 6) Slide the brackets onto the barrel shafts.
 - The tension bracket (plate with tension lock) goes on the end of the barrel with the rotating shaft that is normally notched or drilled to match the type of tension adjusting wheel provided.
 - The operating bracket (with operating mechanism) goes on the opposite end of the barrel with the fixed shaft that is normally keyed.
 - The end of the barrel should be tight against the bearing in the operating bracket.
 - There should be clearance between the barrel and the tension bracket.
- 7) It is recommended that operating bracket components be assembled now. Operating bracket components must be set tight against the outside of the bracket bearing. Use washers to shim for alignment if necessary. (As an alternative, this may be done after the barrel and brackets are raised and bolted to the wall angles.)

NOTE: Assembly details are included for typical push-up, chain, crank and motor operated doors. For motor operated doors, refer to supplemental installation instructions provided with the motor operator.

- 8) Remove the truss head bolts and washers from across the barrel. Raise the barrel and brackets into position between the tops of the wall angles. **CAUTION: Use a hoisting method adequate to safely lift the size and weight of the barrel.** Bolt the brackets to the inside of the wall angles with the flat head bolts, washers and hex nuts provided.
- 9) Raise the curtain, with the lead slats pointing away from the wall, to below the barrel. **CAUTION: Use a hoisting method adequate to safely lift the size and weight of the curtain.** Set slings around the barrel and the curtain. **CAUTION: Use a minimum of 2 slings spaced across the barrel, but as many as required to safely support the size and weight of the curtain.** Set the curtain into the slings and cut the bands around the curtain.
(Continued on next page)

(Continued)

Unroll enough curtain to reach the barrel. Feed the curtain between the back of the barrel and the slings. Turn the barrel to bring the curtain over the top and around to the front. Center the curtain between the brackets. Align the slots in the lead slats with the nuts welded to the barrel. The lead slat at each side of the curtain must be against the endlock. Attach the lead slats to the barrel with the truss head bolts and washers previously removed.

- 10) Slide the tension adjusting wheel onto the shaft extending through the tension bracket. If the shaft is drilled or keyed to secure the tension adjusting wheel, install the pin or key provided (and tighten any set screws).
- 11) Insert a winding bar into the top of the tension adjusting wheel and pull down, away from the wall, to wind the spring assembly. Carefully continue adding tension until the curtain coils itself nearly completely around the barrel. When the curtain is hanging balanced, lock the tension wheel with the tension pin.



WARNING! – Components under **extreme spring tension** can cause **SERIOUS INJURY** or **DEATH**.

- 12) Attach the guides to the insides of the wall angles as follows:
 - U-channels/formed angles attach to the wall angles with special headed bolts and require washers under the flange nuts.
 - Angle guides attach to the wall angles with hex head bolts and require washers under the bolt heads and the flange nuts.
 - Extruded guides attach to the wall angles with truss head bolts and require washers under the flange nuts.
- 13) Make sure the curtain stops are in position and secured to the guides. Adjust the spring tension so the bottom bar wants to raise up to the curtain stops. Remove the slings from around the curtain and barrel. Try the operation of the door and adjust spring tension as necessary so the curtain is as balanced as possible. **CAUTION: Adjust spring tension only when the curtain is in the open position.**



WARNING! – Components under **extreme spring tension** can cause **SERIOUS INJURY** or **DEATH**.

- 14) If intermediate hood support(s) are provided, install now. Space support(s) equally between the brackets. The top of the support(s) must be even with the top of the brackets. Drill holes as indicated on the “WALL BOLT SCHEDULE” for the wall bolt type used and attach supports.
- 15) Align the brackets so they are square (not “toed in” or “toed out”). If a hood is provided, lift the hood, set in place centered between the brackets, and attach to the band on each bracket (and intermediate supports) with sheet metal screws provided.
- 16) Make sure WARNING labels are attached to the door (or the to wall if the guides are concealed).

WALL BOLT SCHEDULE – SERVICE DOORS & GRILLES

WALL CONSTRUCTION	OPENING WIDTH	SUGGESTED WALL BOLT TYPE	WALL BOLT SIZE	DRILL SIZE	MINIMUM HOLE DEPTH
Concrete	to 16'	Wedge anchor	3/8" x 3"	3/8"	2 1/4"
	over 16' to 30'	Wedge anchor	1/2" x 4"	1/2"	3"
Filled CMU, brick or concrete	to 16'	Sleeve anchor	1/2" x 3"	1/2"	3"
	over 16' to 30'	Sleeve anchor	5/8" x 4"	5/8"	4"
Drywall/16 ga. metal stud	to 16'	Self-tapping screw	3/8" x 2"	5/16"	N/A
	over 16'	Not Recommended	N/A	N/A	N/A
Drywall/wood stud	to 16'	Lag screw	3/8" x 3"	1/4"	N/A
	over 16' to 24'	Lag screw	1/2" x 4"	11/32"	N/A
3/16" (min.) structural steel	to 16'	Self-tapping screw	3/8" x 1"	Letter "S"	N/A
	over 16' to 30'	Machine screw	1/2" x 1"	27/64"	N/A

WALL BOLT SCHEDULE – COUNTER SERVICE DOORS

WALL CONSTRUCTION	OPENING WIDTH	SUGGESTED WALL BOLT TYPE	WALL BOLT SIZE	DRILL SIZE	MINIMUM HOLE DEPTH
Concrete	to 20'	Wedge anchor	3/8" x 3"	3/8"	2 1/4"
Filled CMU, brick or concrete	to 20'	Sleeve anchor	1/2" x 3"	1/2"	3"
Drywall/16 ga. metal stud	to 20'	Self-tapping screw	3/8" x 2"	5/16"	N/A
Drywall/wood stud	to 20'	Lag screw	3/8" x 3"	1/4"	N/A
3/16" (min.) structural steel	to 20'	Self-tapping screw	3/8" x 1"	Letter "S"	N/A

GENERAL NOTES:

- 1) Length of wall bolts is generally referenced from the bottom of the head, except for wedge anchors which are referenced by overall length.
- 2) Length of wall bolts must be increased accordingly if the door is attached to the jambs through another material (such as drywall, veneer, stucco, plaster, tile, etc.) depending on the thickness of that material.

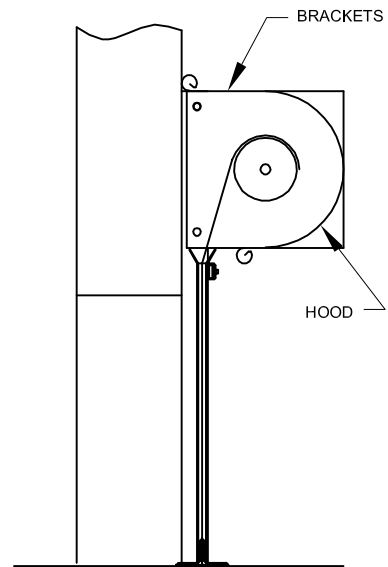
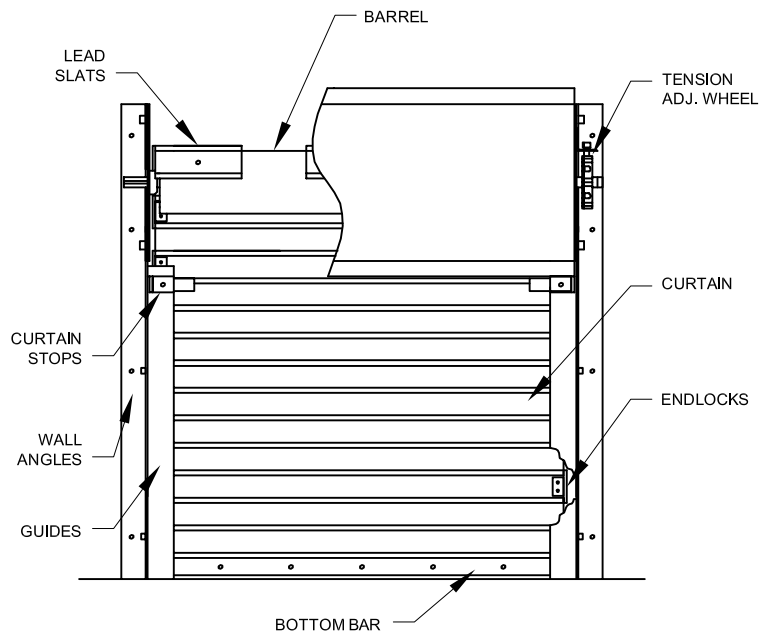

FACE MOUNT

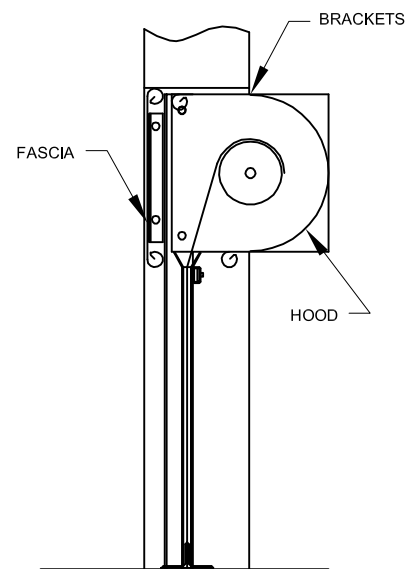
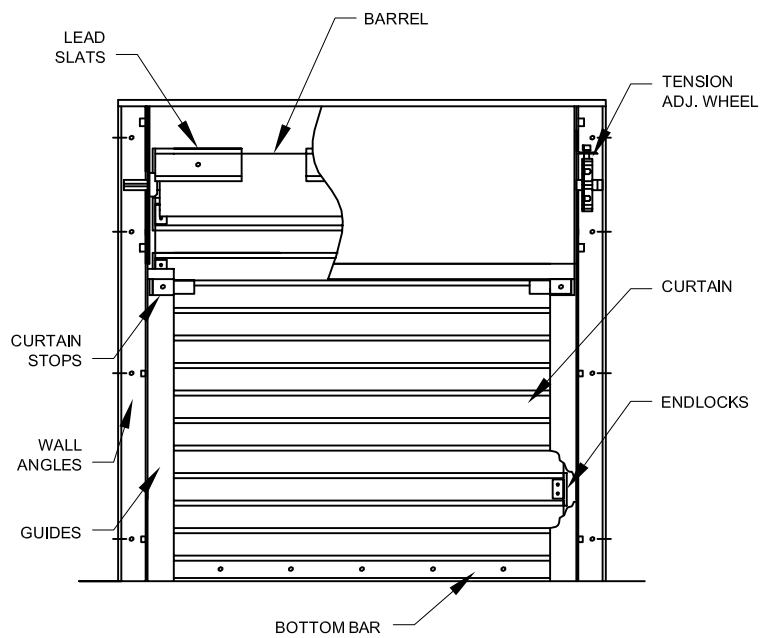

BETWEEN JAMB MOUNT

**GENERAL NOTE:
DOOR WIDTHS MAY
NOT BE THE SAME
AS OP'NG WIDTHS**

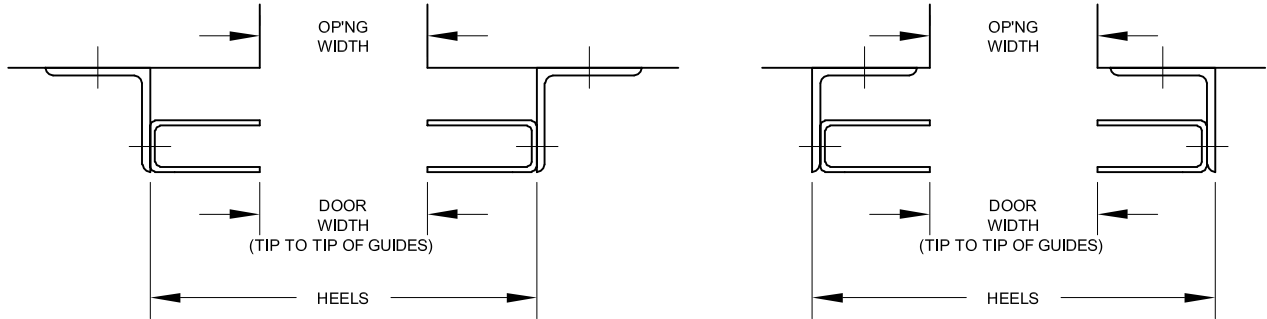

"Z" GUIDE CONFIGURATION

"E" GUIDE CONFIGURATION

**FACE MOUNT
(U - CHANNEL GUIDES SHOWN - ANGLE GUIDES SIMILAR)**

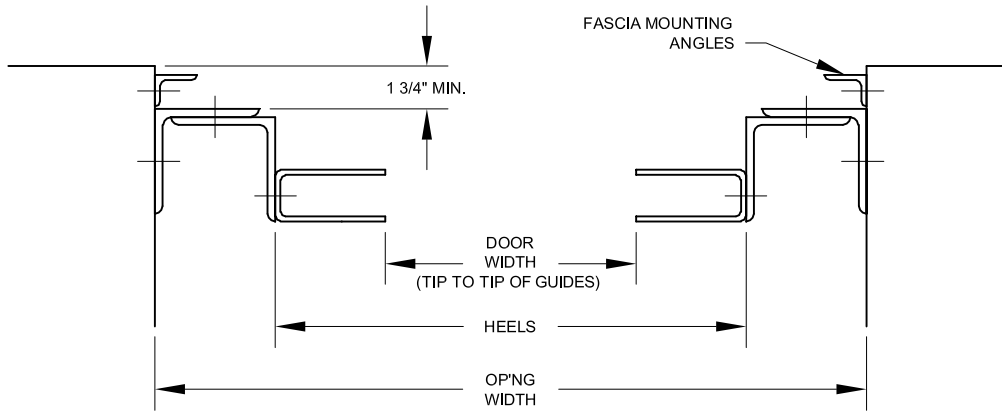

**BETWEEN JAMB MOUNT
(U - CHANNEL GUIDES SHOWN - ANGLE GUIDES SIMILAR)**

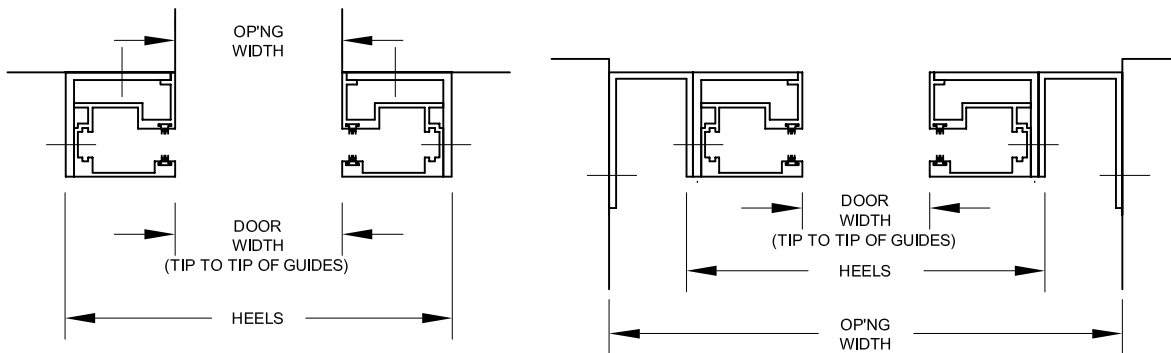

FACE MOUNT

BETWEEN JAMB MOUNT

(EXTRUDED GUIDES SHOWN - FORMED GUIDES SIMILAR)

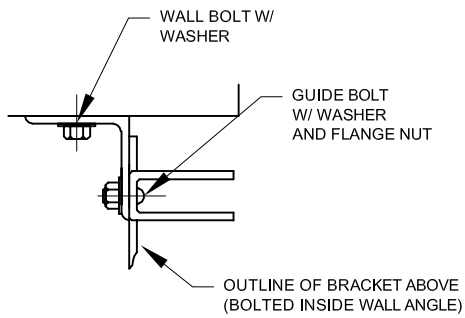

U-CHANNEL GUIDE

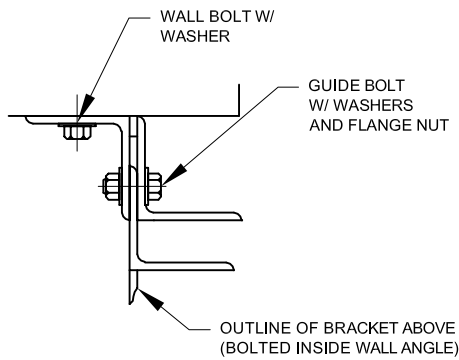

ANGLE GUIDE

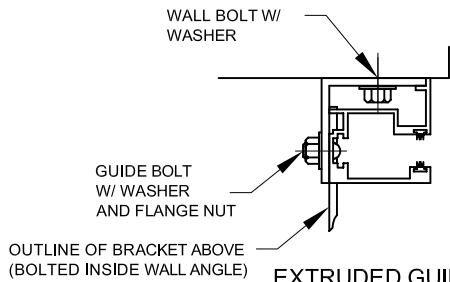
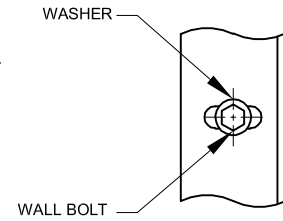

EXTRUDED GUIDE

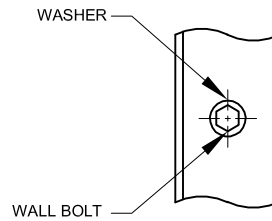

GUIDE INSTALLATION & ASSEMBLY

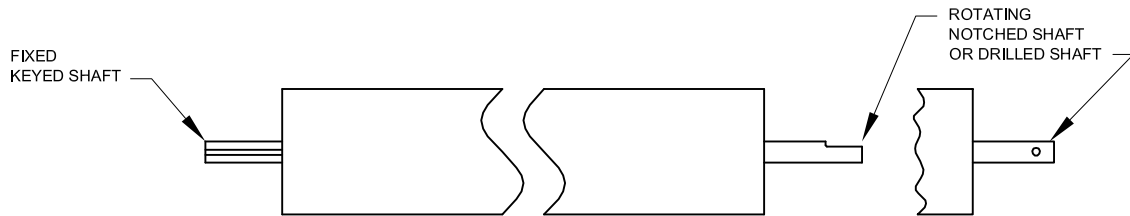

LEFT HAND OPERATION IS SHOWN-
RIGHT HAND OPERATION IS OPPOSITE

OPERATING
SIDE

TENSION
SIDE

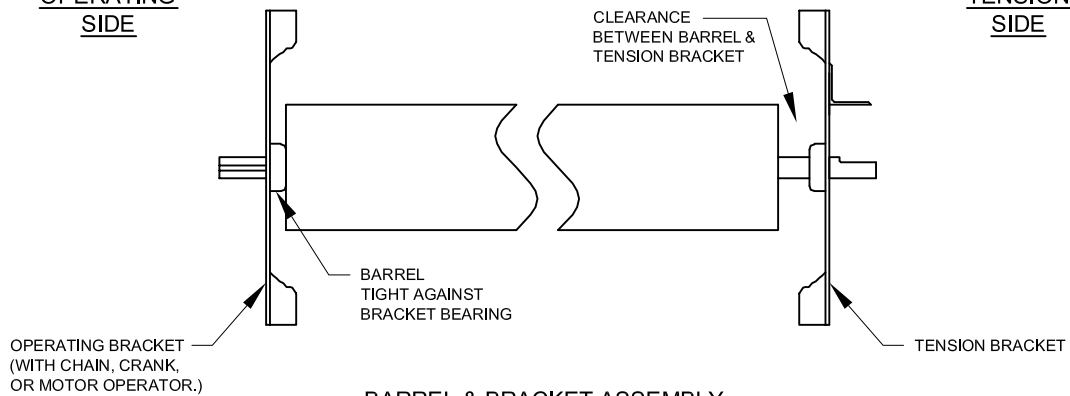

BARREL & BRACKET ASSEMBLY

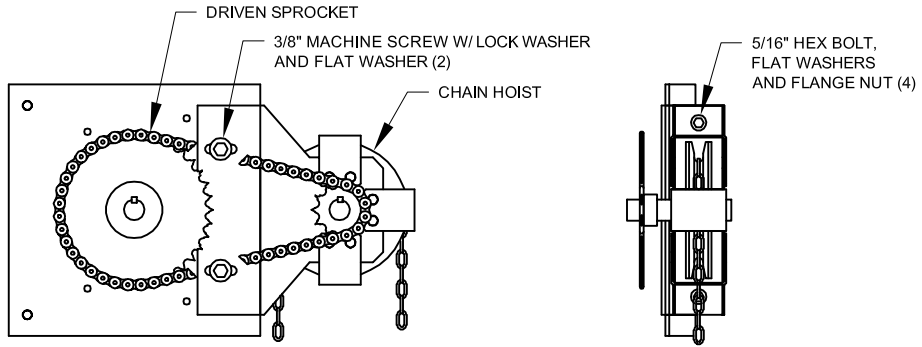

CHAIN OPERATOR WITH REDUCTION SPROCKETS

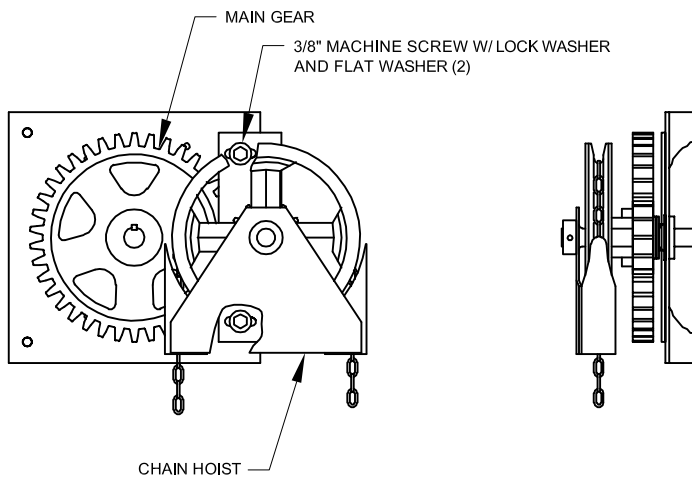

CHAIN OPERATOR WITH SINGLE GEAR REDUCTION
(12" BRACKET ONLY)

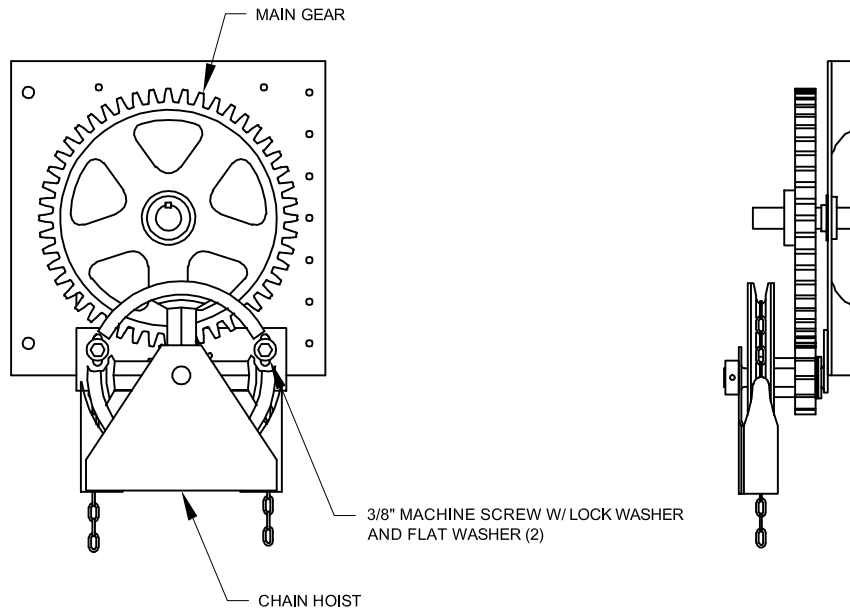

CHAIN OPERATOR WITH SINGLE GEAR REDUCTION

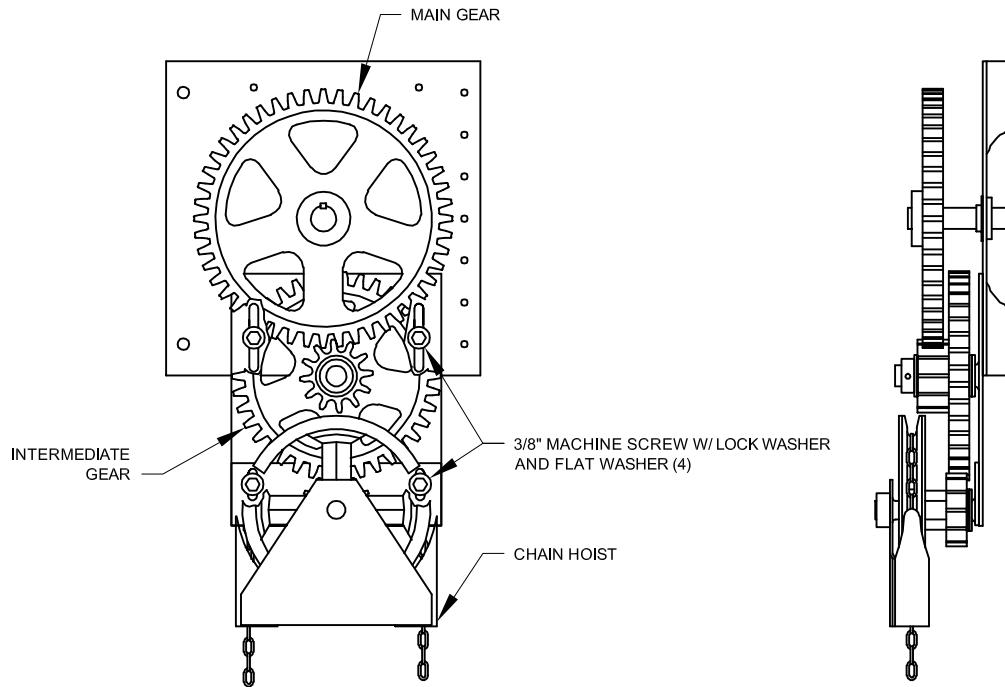

CHAIN OPERATOR WITH MULTIPLE GEAR REDUCTION

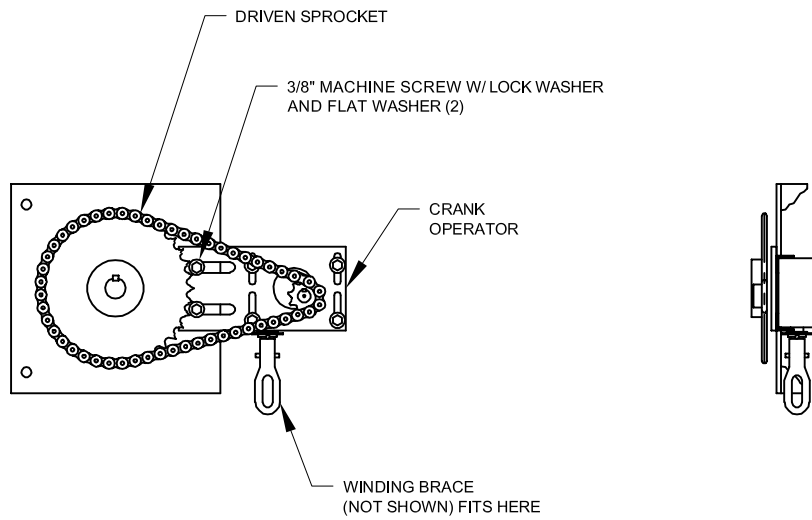

CRANK OPERATOR WITH REDUCTION SPROCKETS

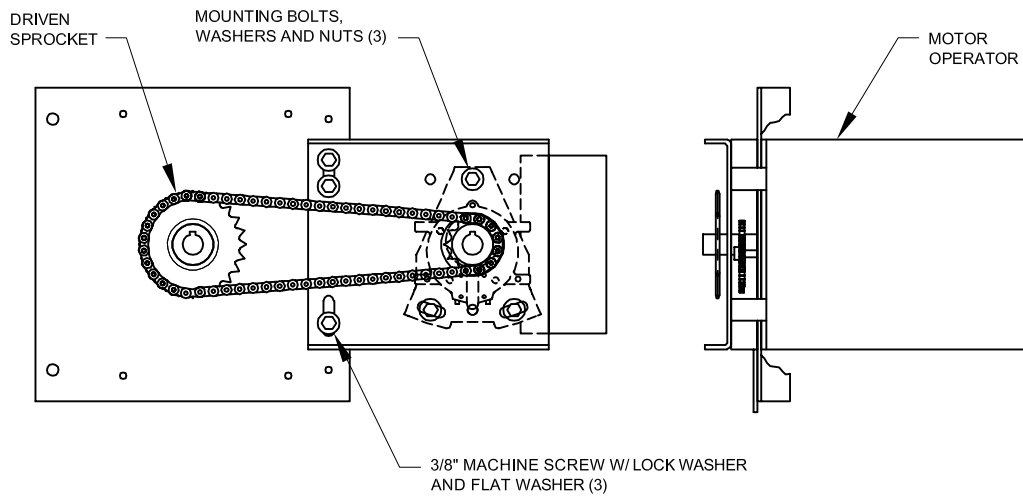

MOTOR OPERATOR WITH STRAIGHT MOUNTING PLATE
(RGRL SHOWN - RGRL-H AND MGH SIMILAR)

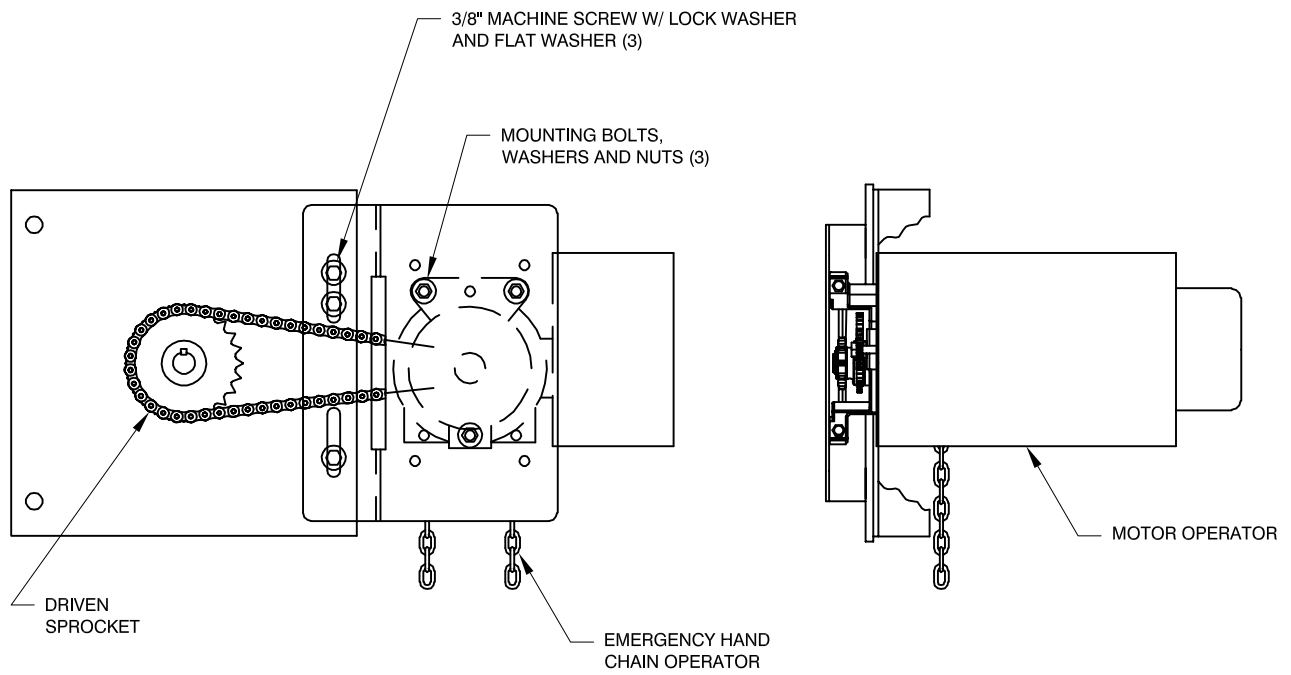

MOTOR OPERATOR WITH BENT MOUNTING PLATE
(MODEL MGH SHOWN - SGH SIMILAR)

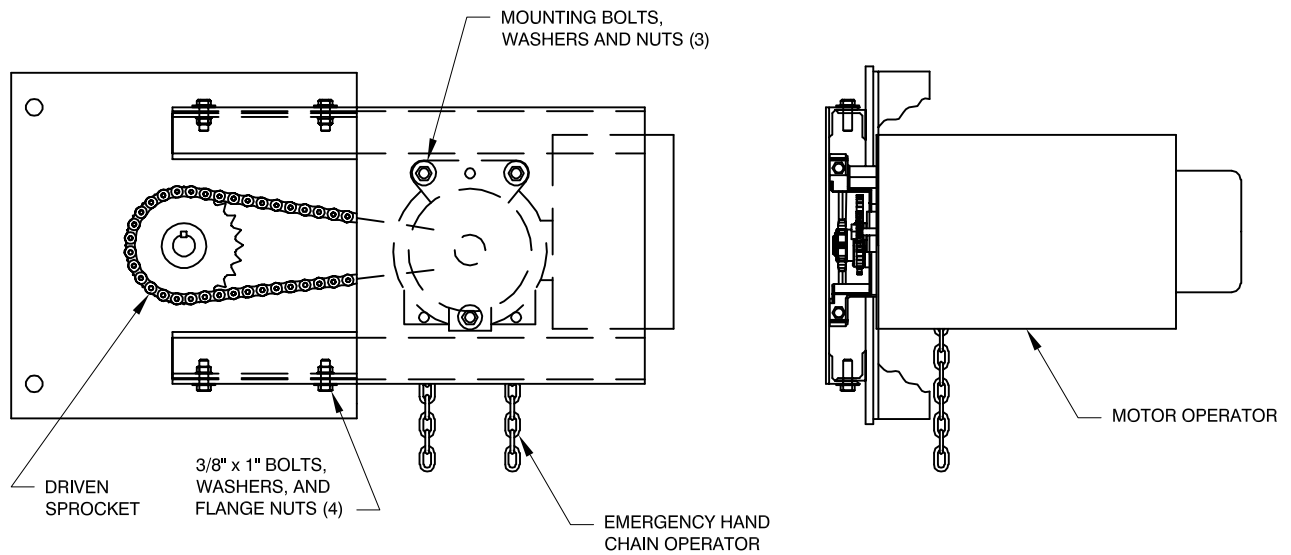

MODEL SGH MOTOR OPERATOR
WITH HEAVY DUTY MOUNTING PLATE

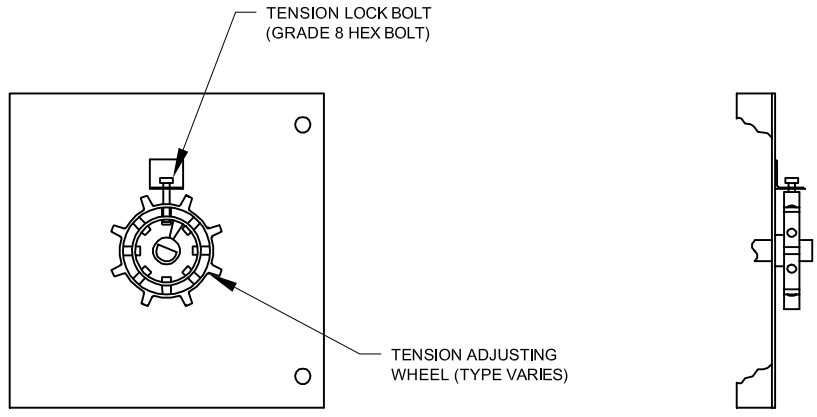

STANDARD TENSION BRACKET

NOTE - TENSION LOCK BOLTS
ARE GOLD IN COLOR WITH SIX
INDICATOR MARKS ON THE HEAD

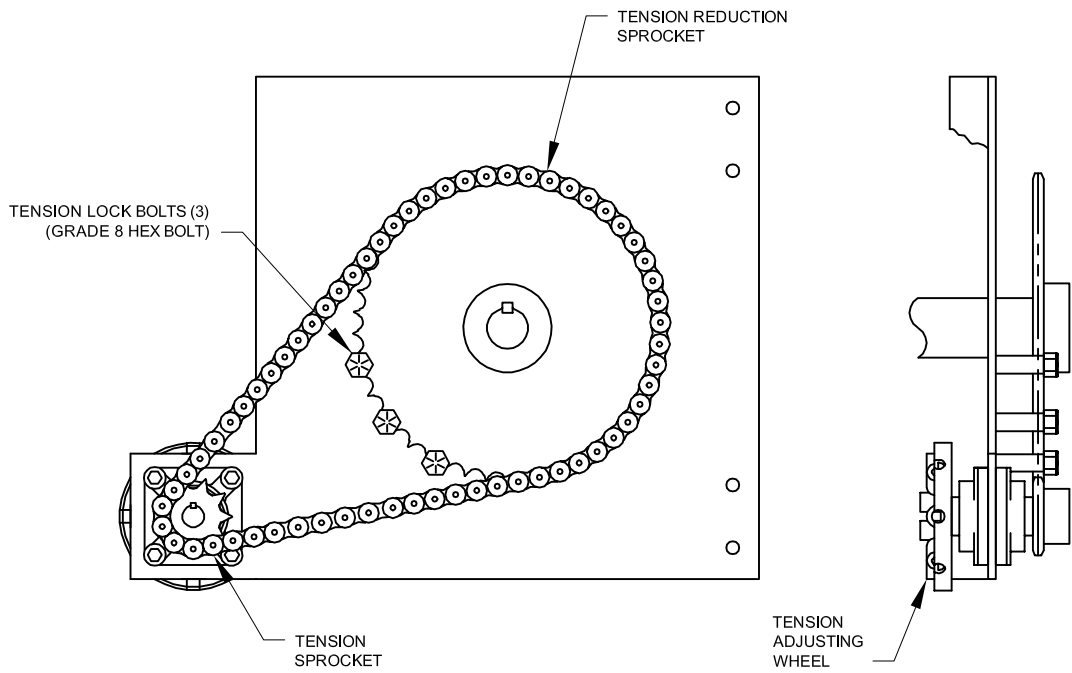

COMPOUND TENSION BRACKET