



MODEL EG

FOLDING GATES

Our Model EG is one of the most popular, dependable folding gates in our product line. Its durable design is constructed to provide high end security at an affordable price.

FEATURES INCLUDE:

- Bottom track and roller system designed for stability and easy installation.
- Multiple locking options available (Quick release JC1000, cylinder, S2000 pin lock, and padlock)
- Pivot option available
- Bi-parting design available
- Up to 32' wide and 12' high (Larger sizes available)

COMMON APPLICATIONS:

- Storefronts
- Jewelry/Liquor Stores
- Schools/Universities
- Pharmacies
- Government/Military



LAWRENCE
DOORS

MADE IN THE USA
SINCE 1925

SPECIFICATIONS

**MAXIMUM SIZE
GATE BODY**

16 ft. wide (single gate) or 32 ft. wide (bi-parting gate), 12 ft. high
Alternating vertical 11 gauge steel channels and intermediate 3/16" steel flat bars, spaced approximately 5" apart, with 3 rows of 3/16" steel lattice bars riveted together though zinc plated steel washers and traveling on formed steel clips

**LEAD & REAR BARS
LOCKING**

14 gauge formed steel box channels
Hasp suitable for padlocking gate in closed position (full height lock post on single gate), pivoting steel tie-back arm to hold gate in open position

BOTTOM ROLLERS

Machined steel ball bearing non-swivel double-wheel rollers in 14 gauge formed steel box channel bottom track with rubber floor pads

TOP GUIDE

Full height vertical 11 gauge steel channels traveling though 14 gauge formed steel box channel top track

FINISH

Factory applied black or gray paint

WARRANTY

One year limited warranty (excluding finish)

COMMON OPTIONS

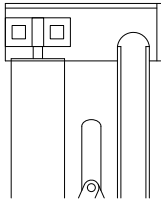

Pivoting Gate

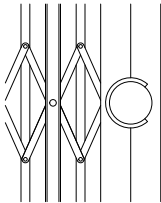

High security keyed pin lock

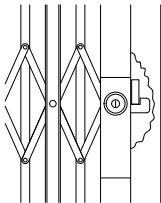

Cylinder locking device

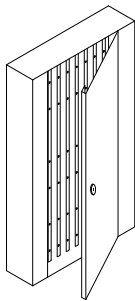

Gate cabinets - surface mount shallow cabinet shown, recessed or deep cabinet designs available

OTHER OPTIONS

- JC-1000 "Quick Release"
- Unequal Pair Gates
- Floating Gate Sections
- Powder Coat Finish
- Mesh or Vinyl Privacy Curtain

GATE DETAILS

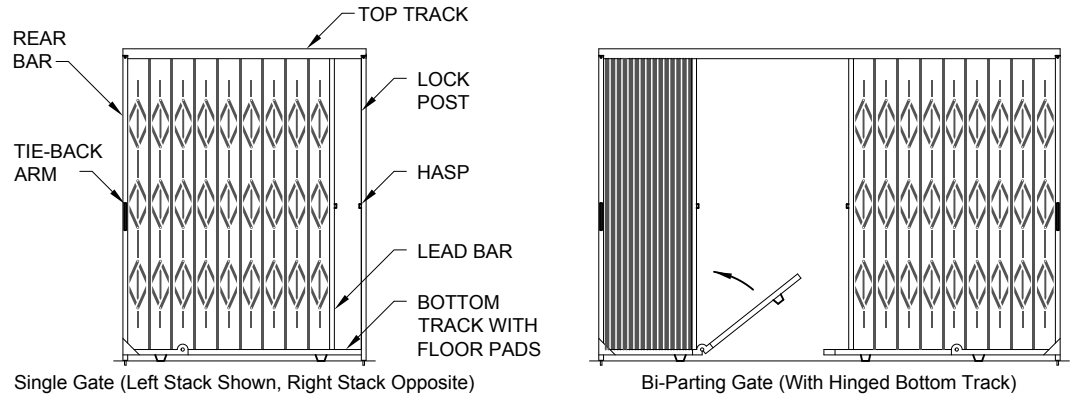

JAMB DETAILS

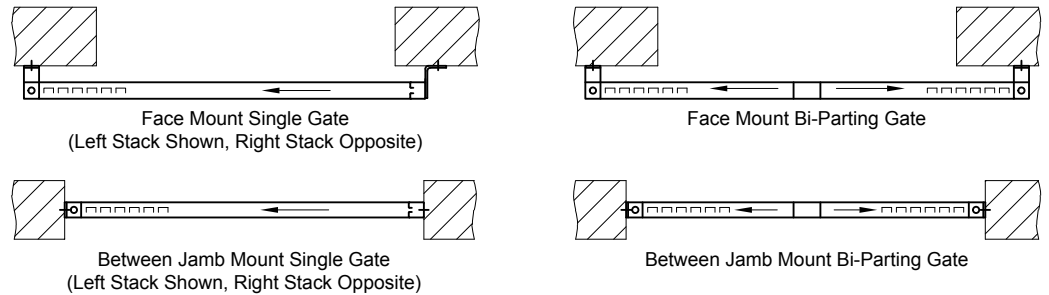

CLEARANCES:

Allow approximately 2" per ft. of gate width for stacking clearance.

HEAD DETAILS (Face mount details shown - between jamb mount similar)

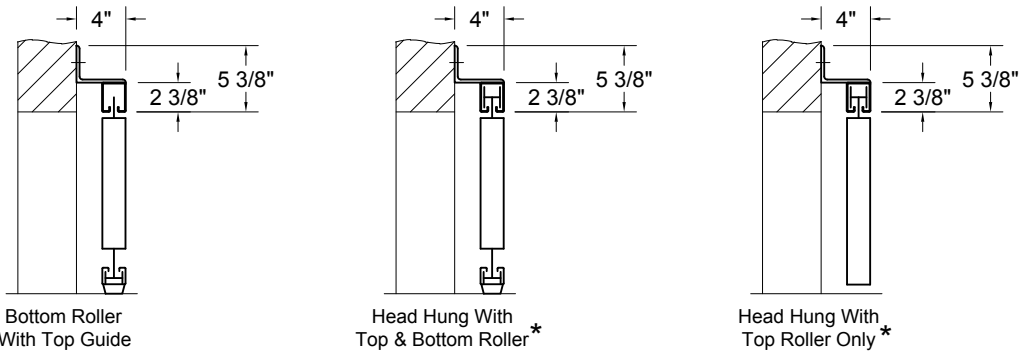

GENERAL NOTES:

Clearances are based upon standard gate construction. Some options may require additional clearance. Shop drawings for specific applications are available. Consult factory for any information not shown.

* Available as an option