

FG SERIES

FIRE DOOR MOTOR OPERATORS

Lawrence "Easy-Reset" fire door motor operators provide fusible link activated automatic closing without a loss of spring tension and eliminate the need for traditional mechanical reset.

FEATURES INCLUDE:

- 1/3 HP to 7 1/2 HP models available
- Multiple voltage options available (115V-1PH, 230V-1PH, 208V/230V-3PH, 460V-3PH, 575V-3PH and voltages in 50Hz)
- Capable with AR-D/AR-D2 and AR-C Series Alarm Release Systems
- Environmental modifications available (Explosion Proof, Corrosion Resistant, Water, Oil and Dust Tight)

COMMON APPLICATIONS:

- Warehouses
- Government/Military
- Pharmacies
- Schools/Colleges

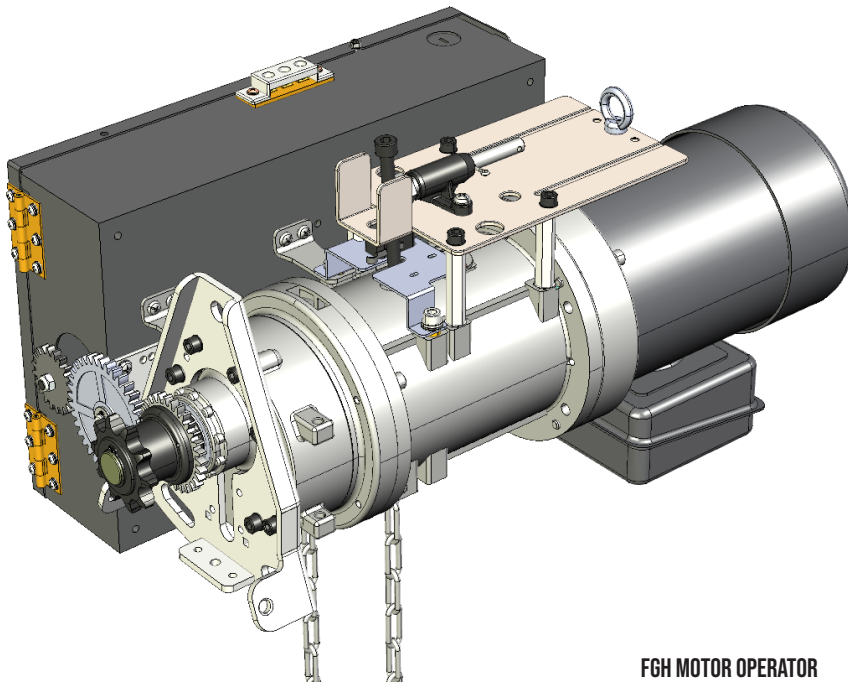

FGH MOTOR OPERATOR

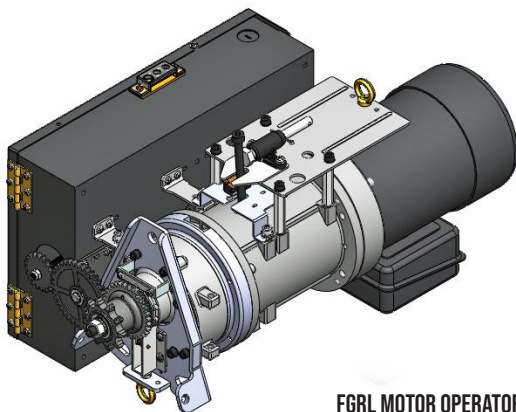

FGRL MOTOR OPERATOR

LAWRENCE
DOORS

MADE IN THE USA
SINCE 1925

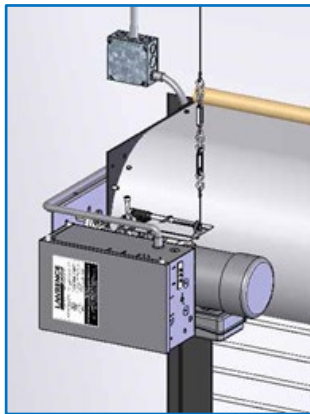

Lawrence **“Easy-Reset”** fire door motor operators provide fusible link activated automatic closing without a loss of spring tension and eliminate the need for traditional mechanical reset – simply reconnect the fusible link release cable and activate the open control to reset the door. All operators feature an internal release device and speed governor system to control automatic closing to a typical average speed of 9” to 12” per second. Their compact “low profile” design means that no additional clearance above the top of the door coil is normally required. High-efficiency in-line gear reducers provide capacities generally exceeding those of right-angle gear reduced operators with the same horsepower ratings.

The fusible link release module can be replaced with an optional AR-C **“Auto-Reset” Conversion Module*** to provide time delayed automatic closing upon activation of alarm or fail safe closing upon a loss of power and is automatically reset when the alarm is cleared and power is restored.

Standard Features

- c-UL-us Listed (UL325-2010 Compliant)
- High efficiency in-line gear reducer
- Low profile design with horizontal front of coil mounting
- Solid-state control board
- On-board open-close-stop buttons
- On-board non-resettable cycle counter
- On-board reclose timer option
- Provisions for connection of monitored & non-monitored sensing devices (multiple monitored sensing devices optional)
- Selectable constant or momentary pressure open & close
- External radio control receiver connections
- 24 volt control circuit
- Overload protection
- Adjustable linear driven limit switches
- 3-button open-close-stop wall mount control station
- NEMA 1 enclosures (environmental modifications optional)

Model FGH – “Easy-Reset” Fire Door Motor Operator with Auxiliary Hoist

- For fire doors in standard cycle usage or high cycle usage applications
- Fusible link activation of internal release and governor controlled closing
- Average operating speed of 6” to 8” per second
- TENV motor
- Solenoid actuated disc brake
- Delay on reverse function (*requires door be provided with a monitored sensing device*)
- Interlocked chain hoist for emergency operation
- 1/2, 3/4#, 1, and 1 1/2 HP – 115v-1ph, 230v-1ph, 208/230v-3ph, 460v-3ph, 575v-3ph
- 2 and 3 HP – 208/230v-3ph, 460v-3ph, 575v-3ph (#3/4 HP on N79 units only)
- NOTE: Consult factory for availability of larger HP, other voltages and 50Hz operators*
- Optional environmental modifications for NEMA 4 (FGHN4 - water, oil and dust tight), NEMA 4X (FGHNX - corrosion resistant and water, oil, dust tight), and NEMA 7/9 (FHN79 “explosion proof” - Class I, Div. 1, Groups C & D / Class II, Div. 1, Groups E, F & G)

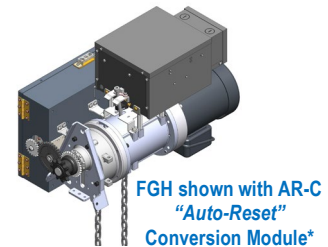

FGH shown with AR-C “Auto-Reset” Conversion Module*

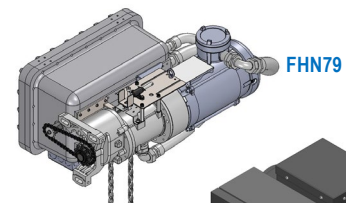

FHN79



FGHN4 (FGHNX Similar)



FGRL with Internal Lock Sensor

Model FGRL – “Easy-Reset” Fire Door Motor Operator with Internal Lock Sensor

- For counter fire doors and small fire doors in standard cycle usage applications
- Fusible link activation of internal release and governor controlled closing
- Average operating speed of 6” to 8” per second
- TENV motor
- Solenoid actuated brake
- Internal lock sensor to stop opening of door upon sensing that locks are engaged
- 1/3 HP – 115v-1ph
- NOTE: Consult factory for other voltages and 50Hz operators*

* AR-C “Auto-Reset” Conversion Module requires a 115v power source (available on FGRL and FGH operators up to 2 HP).

Lawrence fire door motor operators are also available as UL Classified and FM Approved Retrofit Fire Door Operators to provide the same state-of-the art technology and superior closing control for most other brands of rolling fire doors.