

PACIFIC Rolling Door Co.
15900 Worthley Drive San Lorenzo, California 94580
(510) 278-3211 (800) PRD-7269 FAX (510) 278-3449

**INSTALLATION INSTRUCTIONS
PUSH-UP FIRE DOOR w/ #128 GOVERNOR**

****** READ THE COMPLETE INSTRUCTION ****
**** PACKAGE BEFORE ATTEMPTING INSTALLATION ******

- A. > If you are installing more than one door, you will find that all major parts and pieces for any one door are marked with corresponding numbers or letters; therefore, a complete door should be composed of parts and pieces bearing the same numbers or letters. DO NOT interchange parts from one door to another.
- B. > Study all the drawings and familiarize yourself with the various parts and names involved.
- C. > Check the packing and hardware list with materials received. Report any shortages at once. Wall bolts are provided based upon wall construction indicated at time of order - if bolts are not correct for actual field conditions, CONSULT FACTORY.
- D. > When the instructions refer you to the right or left side of the door, it will be facing the door as it is mounted on the wall.
- E. > This is a listed fire door and must be installed in accordance with these instructions. Any deviation may have a severe impact on the fire protection capability of the fire door.
- F. > The fire door must be installed in accordance with all national, regional and local codes and ordinances. The door must be installed in accordance with NFPA 80. The authority having jurisdiction must be consulted when deviating from accepted standards and will have the final say on all matters relating to the installation and acceptance of the door.
- G. > During installation, remember that all guides, brackets, barrel and components must be installed so that they are plumb and level.
- H. > Your fire door may be provided with a backhood/fascia. If so, determine now if it has to be installed prior to the installation of the door itself.
- I. > CAUTION - the barrel weight is not symmetrical about the centerline. The barrel is heavier on the tension end.
- J. > Personal and equipment safety rules should be adhered to at all times. Depending on the size of the door, you may need assistance and/or equipment to safely install the door.

INSTALLATION

Installation of the fire door will be in two parts. Part I is the basic layout and installation of the door. Part II is the fusing of the fire door.

PART I

NOTE: If your door is mounted between the jambs, it is provided with extra angles. Install the extra angles as shown in the plan view drawing, following the same procedure as noted for the wall angles. Then bolt the wall angles to the extra angles as shown, and proceed with the balance of the installation.

1. Locate the center of the opening at the top of the opening. Use a plumb bob to locate the center of the opening on the floor. Locate the heel to heel dimension as shown on the plan view drawing. This dimension is critical. Measure one half of the heel to heel dimension and mark this on the wall on each side of the opening. Mark this at the top and bottom of the opening.

2. Look at the plan view drawing to see which guide is for the left and which one is for the right. Take the guides apart and stand the wall angles against the wall and align the back of the wall angle with the heel to heel marks that you put on the wall.
3. This fire door is designed to allow for upward expansion, so the guides set on the floor. Check the floor for level. If the floor is not level, raise the lower wall angle as required to compensate. The tops of the wall angles must be in level alignment with each other. Fire door guides have slotted holes to allow for expansion during a fire. All wall bolts must be placed in the top of the slots. Mark and drill the holes accordingly.
4. After you have drilled the wall bolt holes, install the wall angles with the wall bolts and galvanized washers provided. Be sure that the wall angles are plumb, and the top of the angles are in alignment with each other.
5. The gear and tension brackets are shown in the drawings. The gear bracket goes on the same end of the barrel as the longer keyed shaft. The tension bracket goes on the same end of the barrel as the shorter rotating shaft. NOTE - the gear end of the barrel is marked INSTALL RIGHT HAND SIDE or INSTALL LEFT HAND SIDE.
6. Put the 1" pipe spacer on the shaft between the barrel and the gear bracket as shown. Place the brackets on the barrel. The barrel should be snug toward the gear bracket. Put (2) 1" washers and the governor wheel (with hub out) on the gear shaft as shown. Install the key and tighten the set screw. Install the cotter pin. Install an eye bolt in the hole in the top front corner of each bracket as shown.
7. Lift the barrel and bracket assembly and bolt the brackets to the top outside face of the wall angles with 1/2" diameter machine bolts, washers, and nuts as shown. Use hex head bolts in the top holes and round head bolts in the bottom holes. CAUTION - use vice grips on the tension shaft to make sure the tension bracket doesn't fall off the shaft during hoisting.
8. After bolting the brackets into place, check to make sure the barrel and spacer are against the gear bracket and there is clearance between the tension bracket and the barrel. Check the barrel to make sure it rotates smoothly and does not bind. If it does not turn freely, check the installation of the brackets and the wall angles for plumb and square.
9. Put the stop bar, 1" brass shim washer, and tension wheel on the tension shaft as shown. Install the key and tighten the set screw. (NOTE: If side clearance is tight, you may want to put these items on in Step 6.) Allow adequate clearance between the tension wheel and the bracket so the tension wheel and stop bar turn freely. The drop-out arm must be able to be raised so that the drop-out pawl engages the tension wheel.
(If your door is provided with hood supports, you may want to lay out the support(s) now and predrill the mounting holes. Use a chalk line across the top of the wall angles to determine the line of the hood.)
10. The drop-out arm and index lever, when properly released, will cause the door to close at a given rate of decent. They must move freely and drop straight down when released. Using a plumb bob, mark a point on the ceiling directly above the center of the door. Install an eye bolt at this point.

11. Using two or more ropes, make slings of equal length to hang off of the barrel. The rope slings will be used for installing the curtain. The rope must be strong enough to hold the weight of the curtain. Lift the curtain and suspend it in the rope slings beneath the barrel as shown. The curtain should be about 2 feet underneath the barrel. The top slat of the curtain is punched to match the curtain fastening screws in the barrel. These are the machine screws and washers that are in line on the barrel. Remove the screws and washers.
12. The curtain must be centered between the brackets. Measure each side to make sure you have the same distance between the curtain top slat and the bracket on each side.
13. Raise the top slat up between the barrel and the wall. Use a hammer to depress the curtain top slat around the punched slots and attach it to the barrel with the machine screws and washers that you removed from the barrel. Use only those screws and washers that were provided. If another type or length of screw is used, it may impede the operation of the internal torsion springs. Check the curtain again to make sure it is centered between the brackets.
14. With the curtain attached to the barrel and supported by the rope slings, roll the curtain onto the barrel. Roll the curtain around the barrel until the footpiece hangs approximately 3" below the opening. Secure the curtain to prevent uncoiling.
15. With the footpiece hanging down and still resting in the rope slings, assemble the guides. DO NOT allow the curtain to drop. Attach the inside and outside angles to the inside face of the wall angles using the 3/8" x 1 1/2" bolts, galvanized washers, and nuts as shown. A galvanized washer is required on each side of the guide assembly. Attach the curtain stops to the guides using the 5/16" x 3/8" round head machine screws.
16. With the footpiece approximately 3" below the opening, take in tension. Make sure that your ladder, scaffolding or man lift is secure and you have firm footing. Using a tension bar of appropriate size, turn the tension wheel in a (clockwise, counter-clockwise) direction as shown, keeping count on the number of turns. Take in _____ complete turns plus _____ holes of tension. Secure the tension wheel with the drop-out pawl/arm. Temporarily clamp or wire the drop-out arm and index lever in place. USE EXTREME CARE IN TAKING IN OR LETTING OUT TENSION. Always maintain control of the tension wheel and make sure the door is in the open position when taking in or letting out tension.
17. Remove the rope slings at this time. Center the governor ring around the governor wheel. Carefully open and close the door several times. The barrel should rotate freely and the curtain should move up and down the guide without binding. If the curtain binds, check the width of the groove. If necessary, adjust operation by taking in or letting out tension. Add or release only one hole of tension at a time. USE EXTREME CARE IN TAKING IN OR LETTING OUT TENSION. Always maintain control of the tension wheel and make sure the door is in the open position when taking in or letting out tension.
18. Raise the door to the full open position. Install the stop bolt in the tension wheel as shown. The door is now ready to test for automatic closing. Release the drop-out arm and index lever and note the speed at which the door closes. The door must close completely to the floor and travel at a rate between 6 inches per second and two feet per second. If the door travels too fast, move the stop bolt back in the opposite direction to which tension is added. If the door travels too slow, move the stop bolt forward in the same direction tension is added. Temporarily re-secure the drop-out arm and index lever to complete the installation.

19. If hood supports are provided, they are installed INSIDE of hoods without flame baffles and installed over the OUTSIDE of hoods with flame baffles. Lift the hood over the bracket bands (and supports) and secure with #10 x 3/8" pan head sheet metal screws as shown.

PART II

20. Study the Fusible Link Arrangement drawing. It is important that you follow the instructions and understand the purpose of the fusible links. The cable and links must be arranged so that the melting of any link will cause the door to drop.
21. A fusible link is required on the drop-out arm, at or near the ceiling on the door side and on the opposite of door side of the wall. Attach an "S" hook and fusible link to the drop-out arm as shown. Locate, drill and install a thru-wall sleeve midway across the opening (unless not required by code). (Suggested sleeve assembly: 1/2" EMT conduit, cut 1" longer than the wall thickness, with 1/2" set collar at each end). On the opposite of door side of the wall, install an eye bolt in the ceiling as shown. Attach an "S" hook and a fusible link to the eye bolt. Make sure the fusible link is far enough from the sleeve to allow for full release of the drop arm.
22. On the other end of the fusible link that is on the opposite of door side of the wall, place an "S" hook and install the wire cable. Run the cable through the sleeve in the wall and through the eye bolt above the door, allowing the cable to extend approximately six inches through the eye bolt. Cut the cable and install an "S" hook and fusible link on the end of the cable. Attach the cable with an "S" hook to the fusible link on the drop-out arm. Run the cable up and through the eye bolt on the top front corner of the tension bracket, through the "S" hook above the center of the door, and down through the eye bolt on the gear bracket. Attach it with a turnbuckle to the "S" hook on the index lever.
23. The cable must be tight enough to hold the drop-out arm and index lever, but without opening the "S" hooks. Remove whatever means was used to temporarily secure drop-out arm and index lever.
24. Visually check the fusible link arrangement and make sure that when any one fusible link melts, the drop arm will release. Drop test the door to insure proper automatic closing.
25. Inspect the door and make sure that all the fasteners are tight. Make sure that the door is operating correctly. Complete the drop test form provided and attach warning labels as indicated by the supplemental instructions. Installation of the fire door is complete.

NOTE: If your fire door is to be installed with a release device in conjunction with a central alarm system or local smoke detector, locate the release device at a convenient location on the wall or ceiling. Install cable on the door side of the wall only and attach fusible links to the drop-out arm and release latch, per the procedures noted above. Detectors must normally be located on both sides of the wall, per the requirements of NFPA-72, as referenced in NFPA-80. Inspect and drop test the door to insure proper automatic closing as noted above.

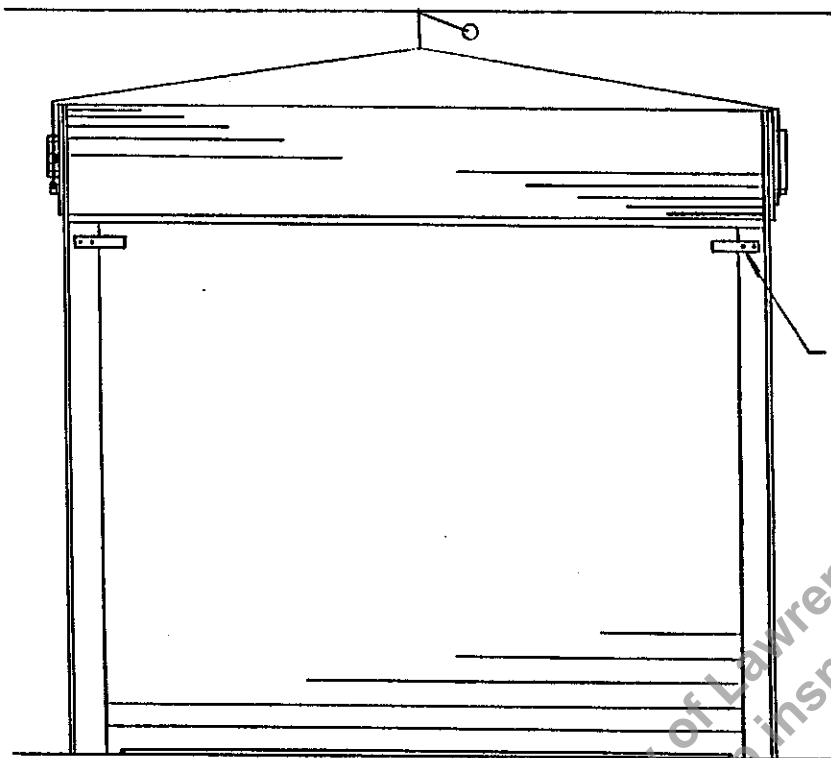

CURTAIN
STOPS

ELEVATION

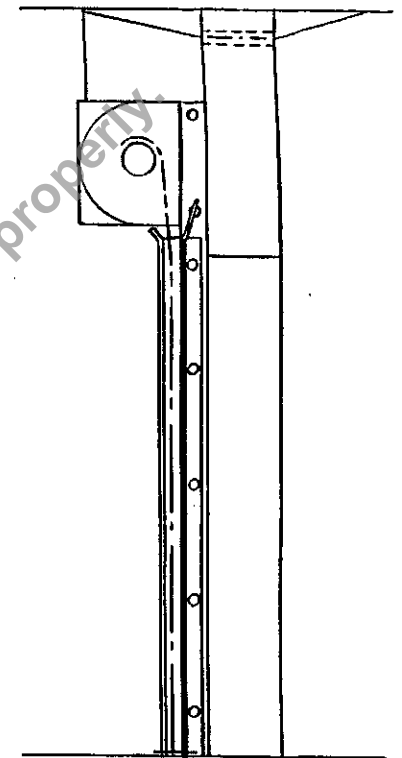

SECTION

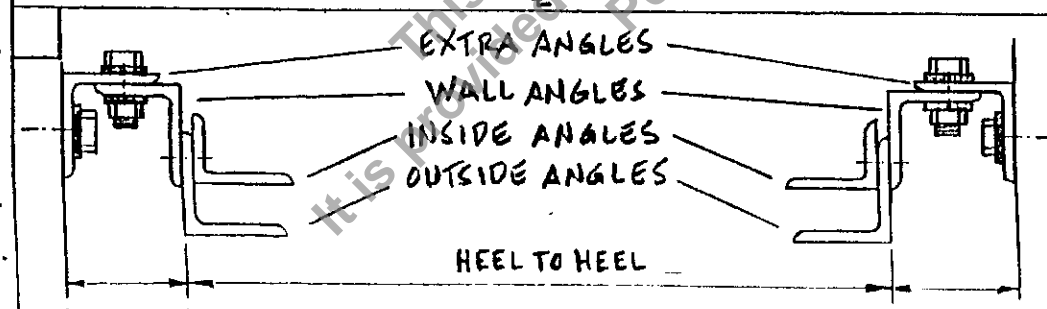
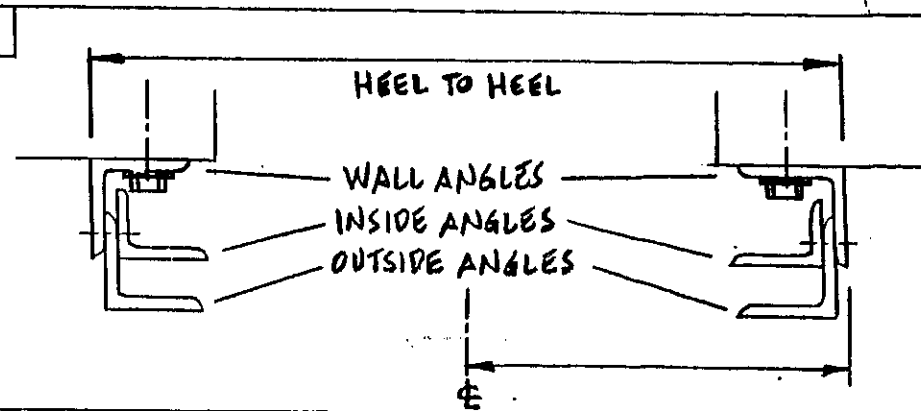
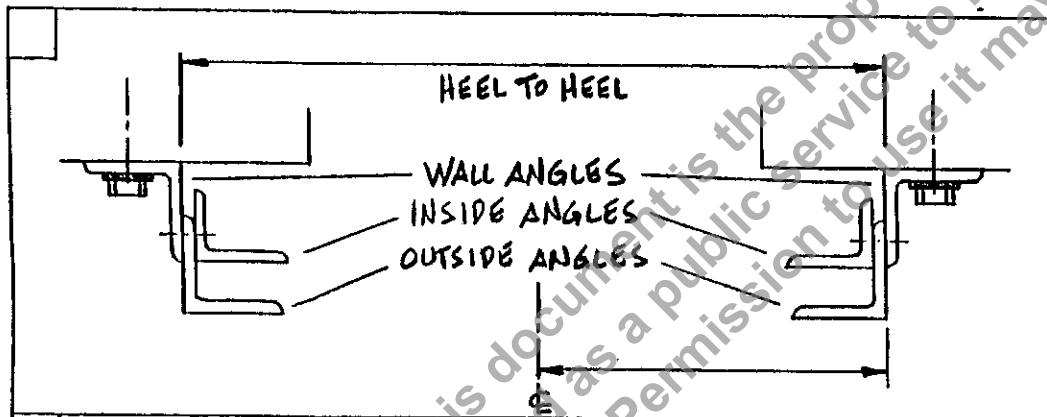

- 1) WALL ANGLES / EXTRA ANGLES ATTACH TO WALL W/ WALL BOLTS PROVIDED
- 2) GALVANIZED WASHERS MUST BE USED AT ALL WALL BOLTS & ASSEMBLY BOLTS.

PLAN VIEWS

WALL BOLT SCHEDULE					
Masonry	Opening	Wall Bolt	Wall Bolt	Drill	Minimum
Jamb	Width	Type	Size	Size	Hole Depth
Concrete	To 14'-0"	Wedge Anchor	3/8" x 3 3/4"	3/8"	3"
	Over 14'-0"	Wedge Anchor	1/2" x 5 1/2"	1/2"	4"
Filled CMU Block or Brick	To 14'-0"	Sleeve Anchor	1/2" x 4"	1/2"	3 3/4"
	Over 14'-0"	Sleeve Anchor	5/8" x 4 1/4"	5/8"	4"
Drywall	Opening	Wall Bolt	Wall Bolt	Drill	Tap
Jamb	Width	Type	Size	Size	Size
16 ga. Metal Stud *	To 14'-0"	Self-Tap Screw	3/8" x 2"	5/16"	---
	Over 14'-0"	N/A	N/A	N/A	---
3/16" Steel Tube	To 14'-0"	Self-Tap Screw	3/8" x 2"	"S"	---
	Over 14'-0"	Machine Screw	1/2" x 2"	27/64"	1/2"-13 NC
NOTE: For 3/8" self-tap screw in steel tube over 3/16" thick, use size "T" drill					
Wood Stud *	To 14'-0"	Lag Screw	3/8" x 4"	1/4"	---
	Over 14'-0"	Lag Screw	1/2" x 4"	11/32"	---
* If Thru-Bolts and Crush Plates are Provided					
(REQUIRED on 3 Hour Drywall Construction w/ Metal Stud or Wood Stud Jamb)					
Jamb	Opening	Wall Bolt	Wall Bolt	Drill	Hole
Type	Width	Type	Size	Size	Depth
As Listed Above	To 14'-0"	Threaded Rod	3/8" x Req'd	7/16"	Thru Wall
	Over 14'-0"	Threaded Rod	1/2" x Req'd	9/16"	Thru Wall

MASONRY JAMB DETAILS

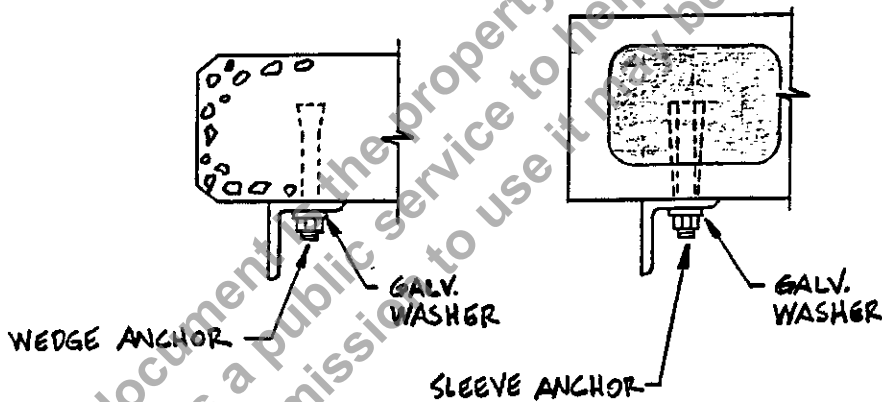

ELEVATION

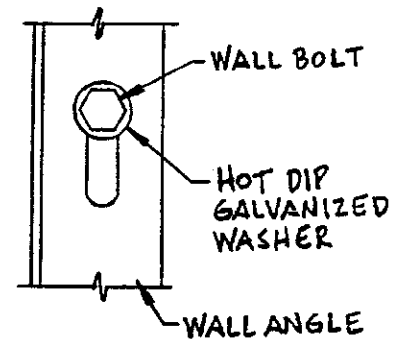

LOCATE WALL BOLT AT TOP OF SLOT

DRYWALL JAMB DETAILS

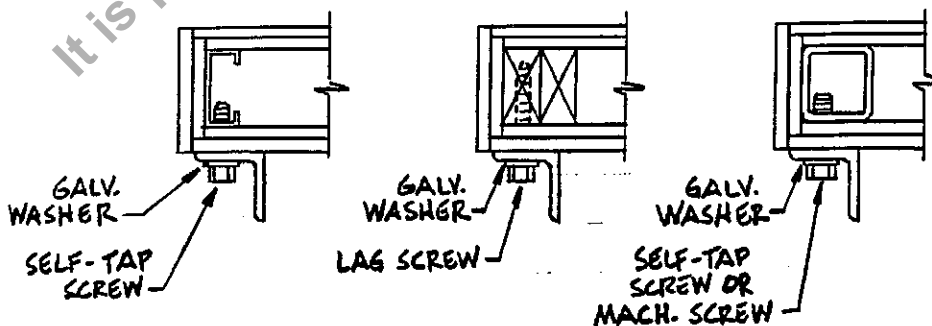

ALTERNATE DETAIL

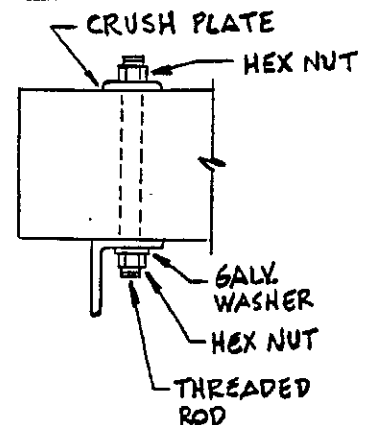

NOTE: DRAWINGS REFER TO R/H OPERATION - L/H OPPOSITE

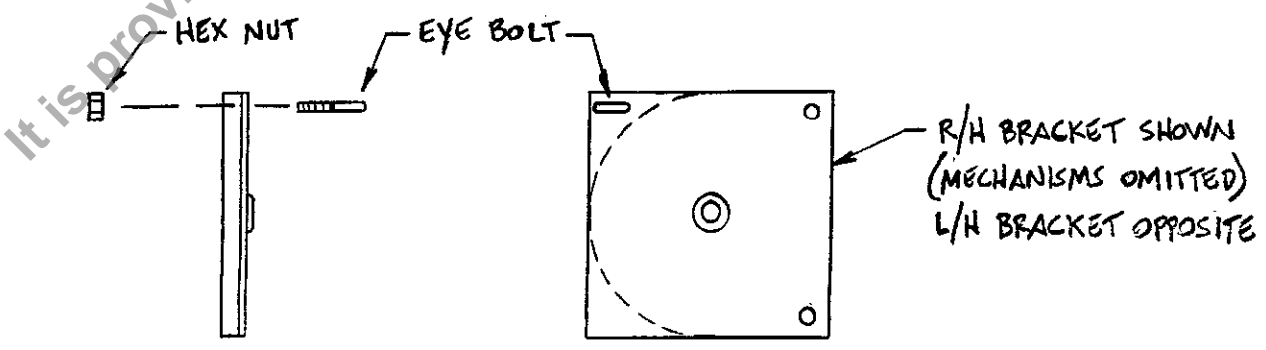
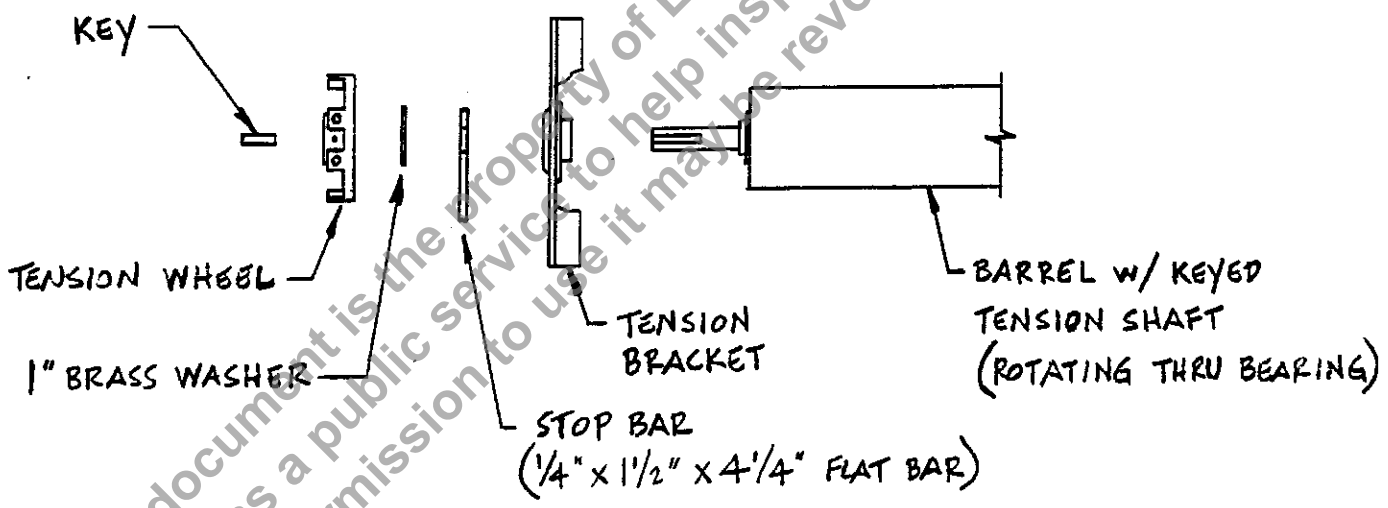
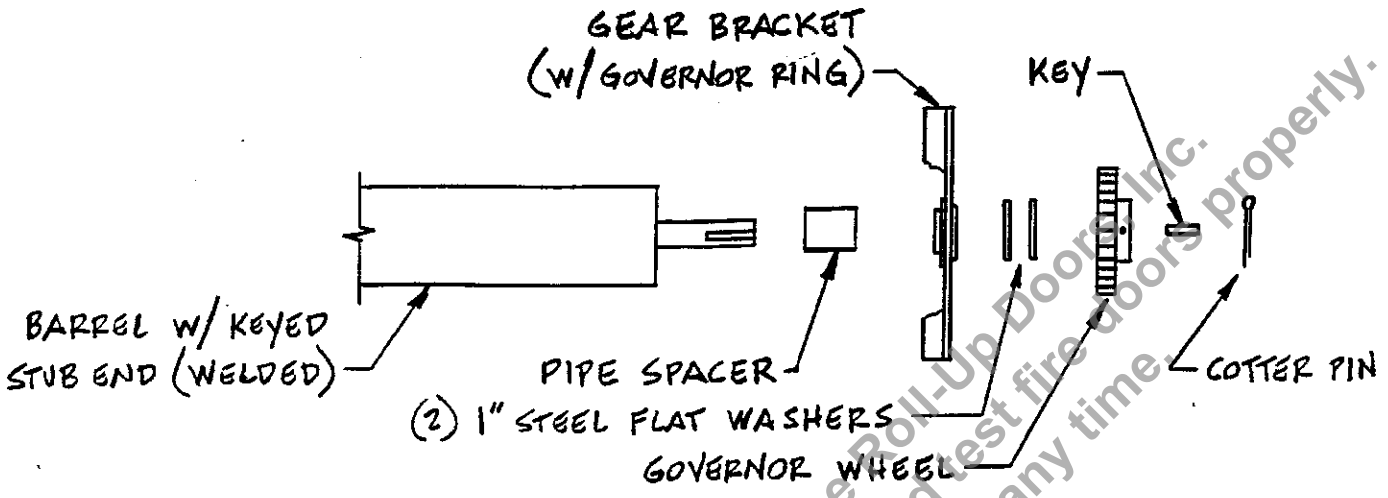

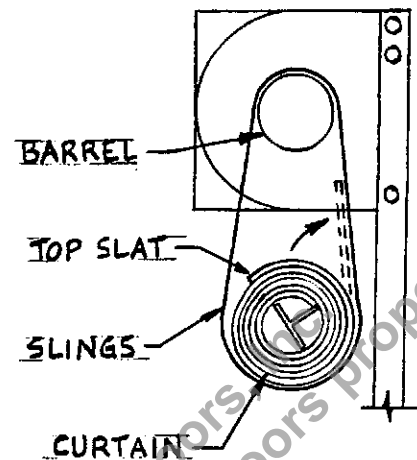
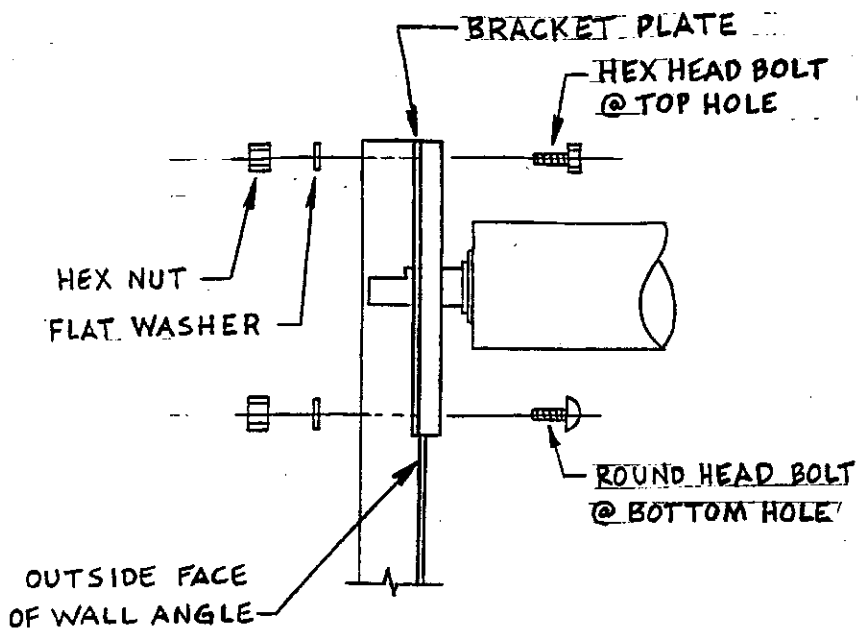

CURTAIN GROOVE WIDTH	
#1 CURVED SLAT	7/8"
#4 FLAT SLAT	3/4"

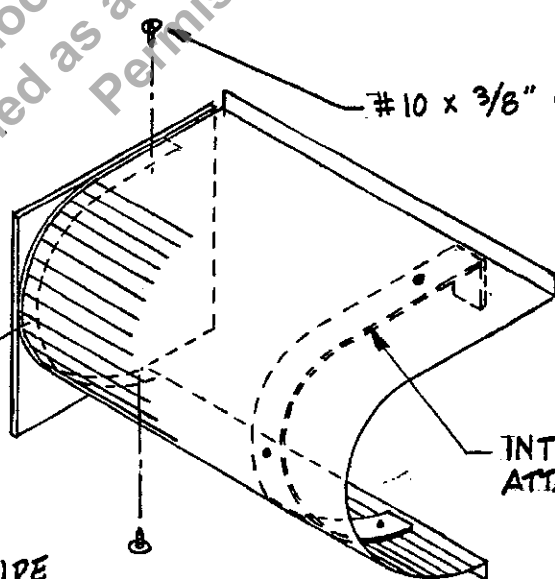
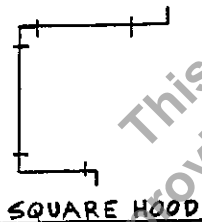
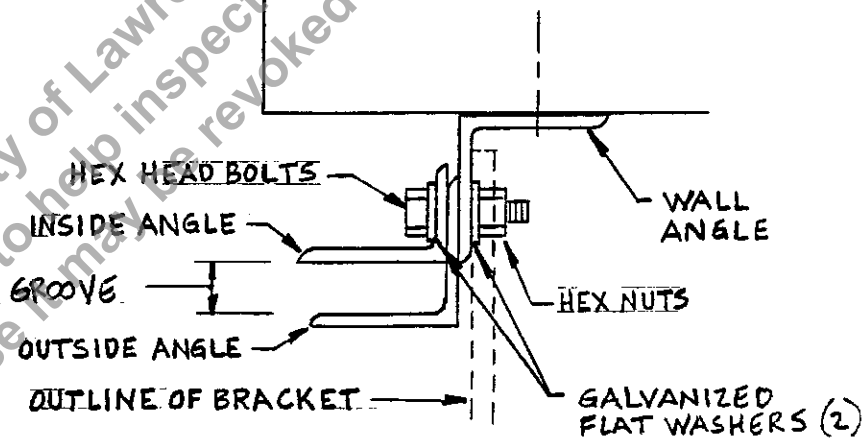

#10 x 3/8" PAN HEAD S.M. SCREWS:
 ROUND HOODS - MIN. 3 EA. SIDE & EA. SUPPORT.
 SQUARE HOODS - 5 EA. SIDE & EA. SUPPORT

NOTE:
 IF THE HOOD IS PROVIDED WITH A FLAME BAFFLE, THE HOOD SUPPORT WILL FIT OVER THE OUTSIDE OF THE HOOD

INTERMEDIATE HOOD SUPPORT(S) (WHEN PROVIDED)
 ATTACH TO WALL W/ ANCHORS PROVIDED

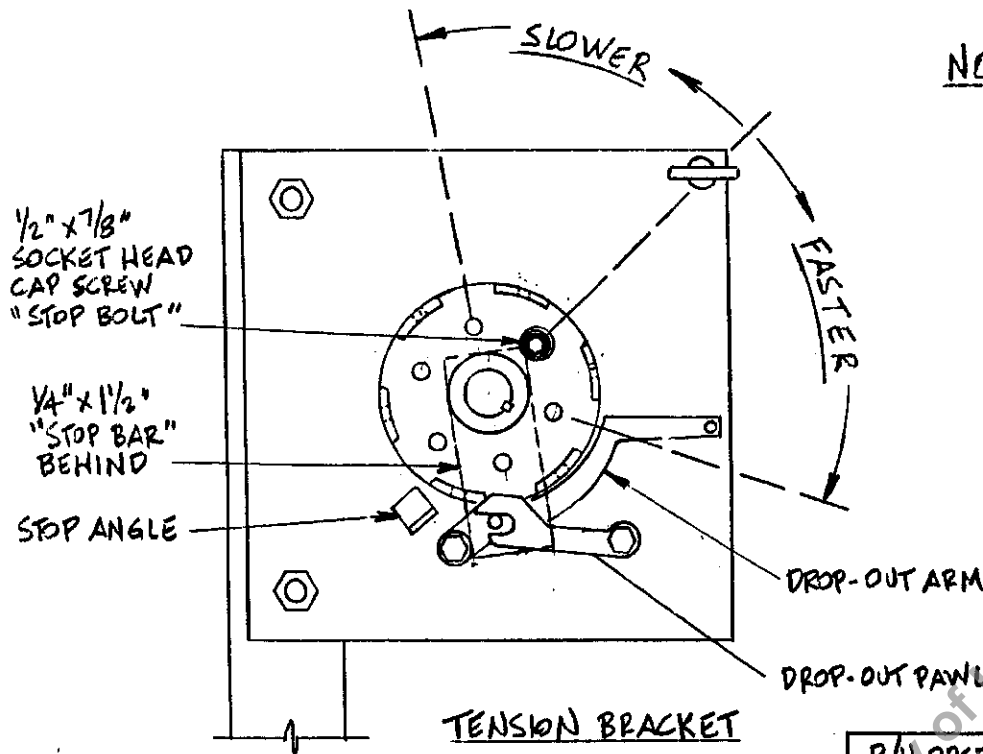

NORMAL

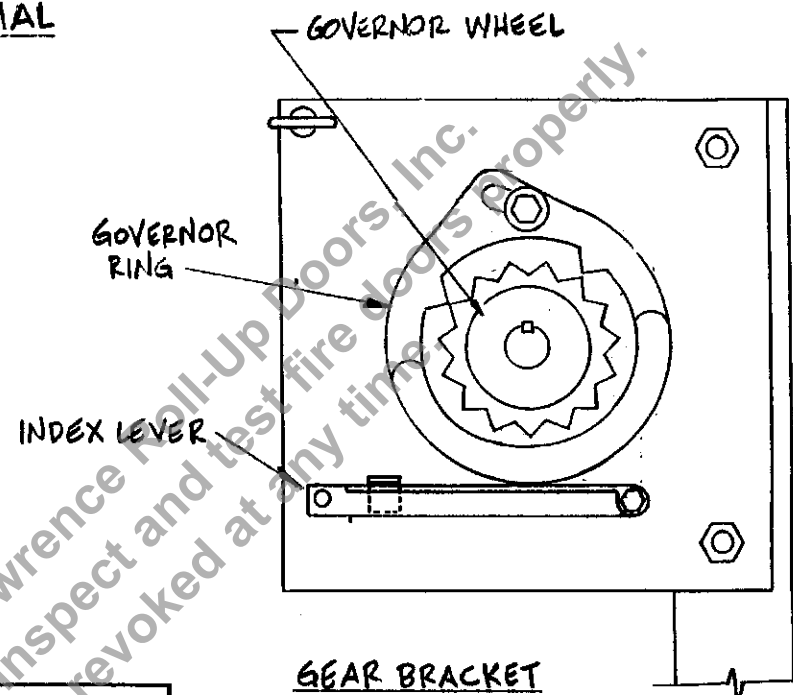

R/H OPERATION SHOWN
L/H OPPOSITE

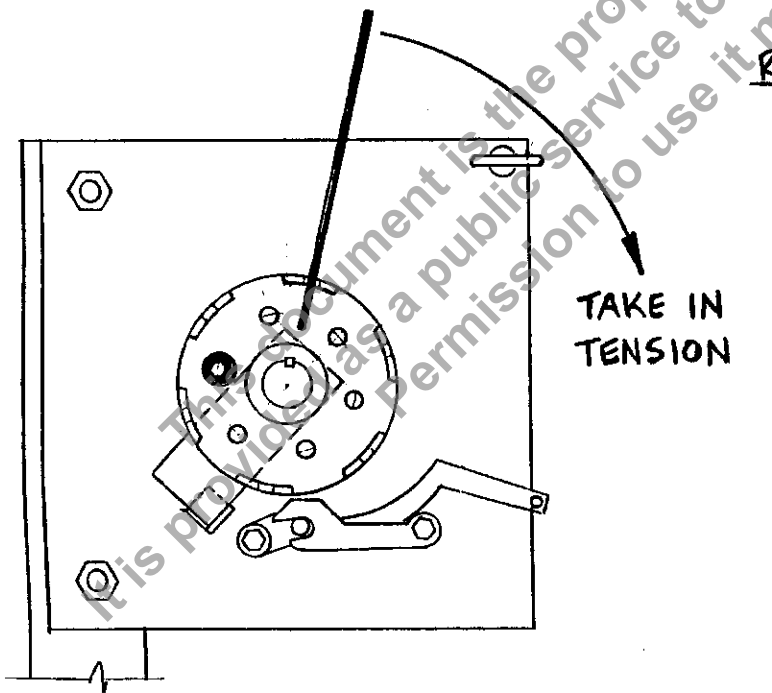

RELEASED

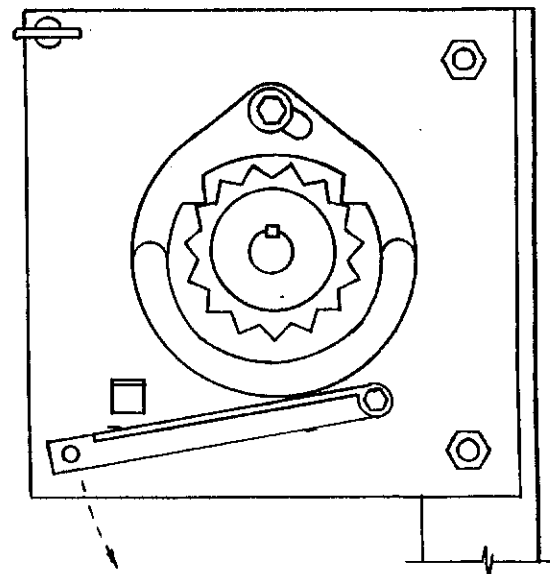

NOTE:

TYPICAL CONFIGURATION AS SHOWN - MODIFICATIONS MAY BE REQUIRED BY ACTUAL FIELD CONDITIONS. CONSULT AUTHORITY HAVING JURISDICTION FOR ACCEPTABILITY.

DETAIL 'B'

1/2" EMT CONDUIT

THROUGH-WALL SLEEVE (B/OTHERS)

1/2" SET COLLAR EA. SIDE OF WALL

DETAIL 'A'

FUSIBLE LINK ARRANGEMENT

TURNBUCKLE AT GEAR BRACKET

NOTE:

CRIMP CONNECTOR W/ LINESMAN SIDECUTTING PLIERS 2 PLACES - DO NOT CUT THROUGH CONNECTOR

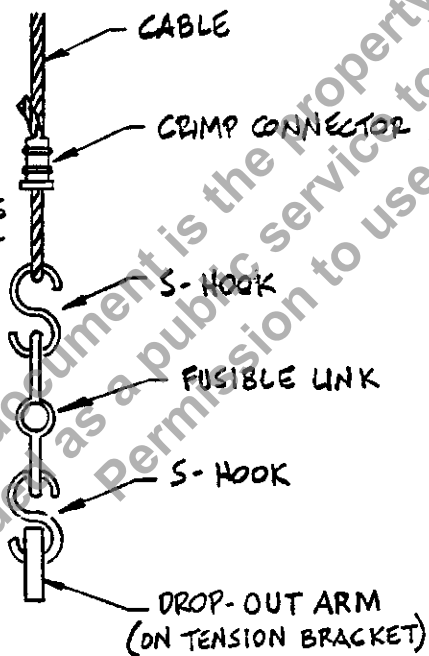

DETAIL 'A'

(TYPICAL FOR ALL FUSIBLE LINK CONNECTIONS)

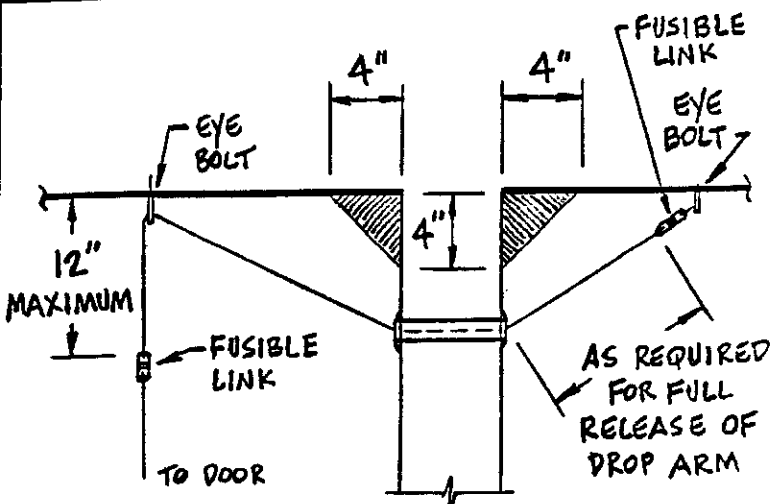

NOTE: FUSIBLE LINK MUST BE LOCATED AT THE DROP ARM AND WITHIN 12" OF THE CEILING ON BOTH SIDES OF THE WALL (UNLESS AN EXTERIOR OPENING) - NEVER LOCATE FUSIBLE LINK IN HATCHED AREAS.

DETAIL 'B'

(FUSIBLE LINK PLACEMENT PER NFPA-80)

SUPPLEMENTAL INSTALLATION INSTRUCTIONS
FIRE DOOR W/ #128 OSCILLATING GOVERNOR
CRANK OPERATED

