

FS SERIES

FIRE DOOR MOTOR OPERATORS

Lawrence "Auto-Reset" fire door motor operators provide time-delayed automatic closing upon activation by alarm or fail safe closing upon a loss of power.

FEATURES INCLUDE:

- 1/3 HP to 2 HP models available
- Multiple voltage options available (115V-1PH, 230V-1PH, 208V/230V-3PH, 460V-3PH, 575V-3PH and voltages in 50Hz)
- Optional R-BBU Battery Backup System Available
- Optional Internal Lock Sensor Feature Available
- Environmental modifications available (Explosion Proof, Corrosion Resistant, Water, Oil and Dust Tight)

COMMON APPLICATIONS:

- Warehouses
- Government/Military
- Pharmacies
- Schools/Colleges

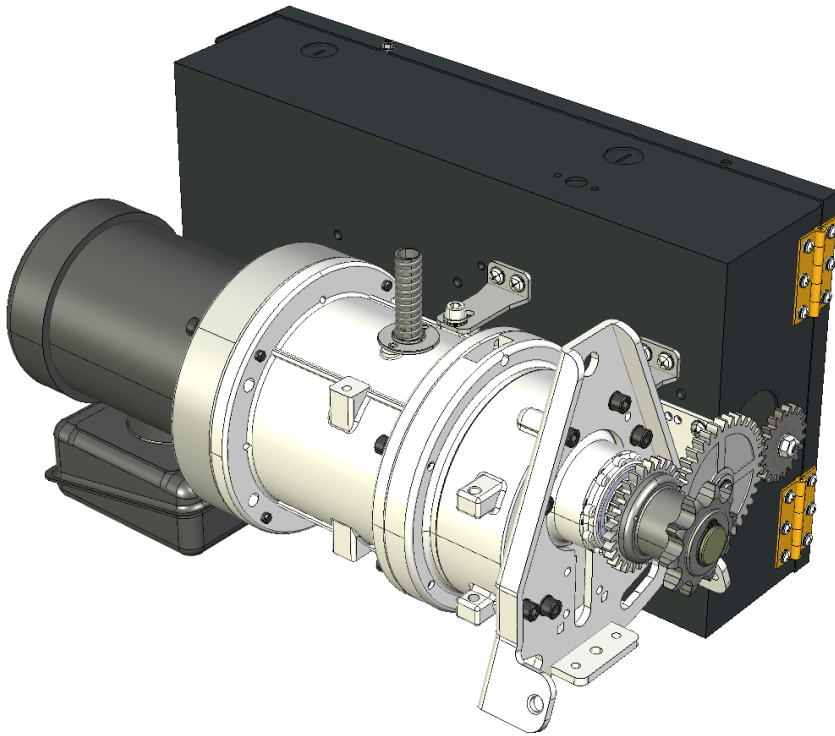

FS MOTOR OPERATOR

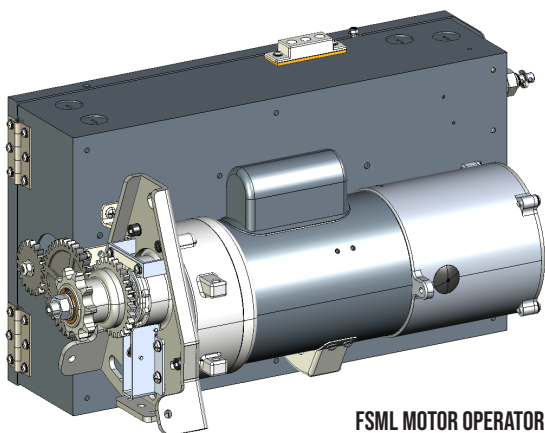

FSML MOTOR OPERATOR

LAWRENCE
DOORS

MADE IN THE USA
SINCE 1925



Lawrence **“Auto-Reset”** fire door motor operators provide time-delayed automatic closing upon activation by alarm or fail safe closing upon a loss of power. They are automatically reset when the alarm is cleared and power is restored. Selectable functions allow doors to reverse upon contact with an obstruction during automatic closing, reopen, and close again* and to automatically re-open after reset. FS series operators feature an internal release device and speed governor system to control fail safe automatic closing to a typical average speed of 9” to 12” per second. Their compact “low profile” design means that no additional clearance above the top of the door coil is normally required. High-efficiency inline gear reducers provide capacities generally exceeding those of right-angle gear reduced operators with the same horsepower ratings.

An optional **R-BBU Battery Backup**# system is available to prevent door closing during a loss of power, and support detectors and warning devices connected to it. A battery indicator can be added to monitor battery life.

Standard Features

- c-UL-us Listed (UL325-2010 Compliant)
- High efficiency in-line gear reducer
- Low profile design with horizontal front of coil mounting
- Solid-state control board
- On-board open-close-stop buttons
- On-board non-resettable cycle counter
- On-board reclose timer
- Provisions for connection of monitored & non-monitored sensing devices (multiple monitored sensing devices optional)
- Selectable constant or momentary pressure open & close
- External radio control receiver connections
- 24 volt control circuit
- Overload protection
- Adjustable linear driven limit switches
- 3-button open-close-stop wall mount control station
- NEMA 1 enclosures (environmental modifications optional)

Model FS – “Auto-Reset” Fire Door Motor Operator

- For fire doors and in standard cycle usage applications (up to 20,000 cycles)
- Alarm activated closing controlled by governor when power is present
- Fail safe activated closing controlled by governor upon power loss
- Provision for connection of fusible link (when required by AHJ)
- Selectable time delayed closing functions
- Selectable obstruction sensing, cycling and reversing functions*
- Selectable automatic re-open function after alarm is cleared and power is restored
- Average operating speed of 6” to 8” per second
- TENV motor
- Solenoid actuated disc brake
- Delay on reverse function (*requires door be provided with a monitored sensing device*)
- 1/3, 1/2, 3/4, 1 1/2 and 2 HP – 115v-1ph, 230v-1ph, 208/230v-3ph, 460v-3ph, 575v-3ph
NOTE: Consult factory for availability of larger HP, other voltages and 50Hz operators
- Optional environmental modifications for NEMA 4 (FSN4 - water, oil and dust tight), NEMA 4X (FSNX - corrosion resistant and water, oil, dust tight), and NEMA 7/9 (FSN79 “explosion proof” - Class I, Div. 1, Groups C & D / Class II, Div. 1, Groups E, F & G)
- Optional wall mount test switch to verify alarm-activated automatic closing function

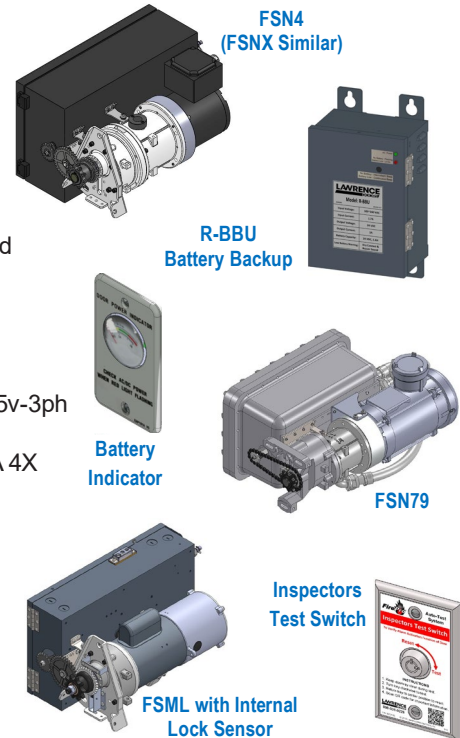

Model FSML – “Auto-Reset” Fire Door Motor Operator with Internal Lock Sensor

- For counter fire doors and small fire doors in standard cycle usage applications
- Internal lock sensor to stop opening of door upon sensing that locks are engaged
- Same features and functions as Model FS
- 1/3 HP – 115v-1ph

* Requires power be present and the operator be connected to a monitored sensing edge on the bottom of the door.

R-BBU is available to provide battery backup for up to 7 hours (3.3 hours on 3/4 and 1 1/2 HP, 2.2 hours on larger HP) and can be provided with an extended battery pack to increase backup time to a total of up to 21 hours (9.9 hours on 3/4 and 1 1/2 HP, 6.6 hours on larger HP).

NOTE: Model FS fire door motor operators do not have an auxiliary chain hoist for emergency operation – if an auxiliary chain hoist is required, a Model FGH should be considered.

Lawrence fire door motor operators are also available as UL Classified and FM Approved **Retrofit Fire Door Operators** to provide the same state-of-the art technology and superior closing control for most other brands of rolling fire doors.