



**INSTALLATION INSTRUCTIONS
AND
OPERATION MANUAL**

**FSML-EP Series
Rolling Fire Door Operators**

UL325-2010 Compliant

Restricted Duty Operators

SMART Control

IMPORTANT INSTALLATION INSTRUCTIONS

WARNING –To reduce the risk of death or serious injury to persons:

1. READ AND FOLLOW ALL INSTALLATION INSTRUCTIONS.

WARNING! – Components under **extreme spring tension** can cause death or serious injury.

2. Install only on a properly operating and balanced door. A door that is operating improperly could cause death or serious injury. Trained door systems technicians make all necessary adjustments and repairs to the door before installing the operator.

Note: Fire door spring tension must be adjusted per the manufacturer's installation instructions to allow for automatic closing during a drop test, fusible link/alarm activation and/or power failure (Power failure condition only applies to operators capable of fail-safe closing).

3. Remove all pull ropes.

4. Unless the door operator includes an internal lock sensing system, or external electrical interlocks are installed, remove or make all door locks inoperative, or secure locks in the unlocked position to prevent operation with the locks engaged.

5. Install the door operator at least 8 feet or more above the floor if the operator has exposed moving parts. If the operator must be mounted less 8 ft (2.44 m) above the floor, then exposed moving parts must be protected by covers or guarding. Contact the manufacturer.

6. Do not connect the door operator to the source of power until instructed to do so.

7. Locate the control station (open-close-stop push button, key station, or the like):

a) within sight of the door

b) at a minimum height of 5 feet above floors, landings, steps, or any other adjacent walking surface and

c) away from all moving parts of the door.

8. Install the Entrapment Warning Placard next to the control station in a prominent location.

9. Make sure the available power supply to be connected to the operator is of the same voltage, frequency, phase and wattage as indicated on the nameplate of the operator.

10. Read and understand the wiring diagram of the operator and the control station and any other equipment to be connected to the operator.

11. Always disconnect power whenever installing or servicing the door operator or door.

12. All wiring must be permanent and comply with National Electrical Code (NEC) and local code requirements.

13. Any change in mounting position may result in a change of operator rotation and consequently in a change of control functions. Consult factory for any changes.

14. For products having a manual release, instruct the end user on the operation of the manual release.

SPECIFICATIONS

MOTOR	
Type:	Restricted cycle duty (20 cycles per hour)
Horsepower:	1/3 hp
Speed:	1700 RPM
Voltage:	115, 230 – 1 phase 208/230, 460, 575 – 3 phase 230 volt 3 phase motor is suitable for use with 208 volts (see <i>Wiring Diagrams and Appendix 6 for wiring change instructions</i>)
Current:	See motor nameplate
ELECTRICAL	
Transformer:	24VAC
Wiring Type:	Momentary pressure open, stop, constant pressure close (provided standard), with provision for momentary pressure close*
Limit Adjustment:	Linear driven, fully adjustable screw type cams.
MECHANICAL	
Drive Reduction:	43:1
Output Shaft Speed:	39 RPM
Door Speed:	6 - 8" per sec. average (typical)
Brake:	Solenoid actuated brake
ENTRAPMENT PROTECTION	
Sensing Edge*:	(Optional) Sensing device attached to the bottom edge of the door.
Non-Contact Device*:	(Optional) Photo eye device.
* Per the requirements of UL Standard 325, the door operator is setup for constant pressure to close the door. As an alternative, the door may be provided with at least one <u>monitored</u> sensing device that will reverse the door upon contact with, or upon detecting an obstruction, during closing.	

Notes:

1. A non-contact sensing device (photo eye) can only be used on doors up to 35 ft. wide (or maximum rated range of device if less than 35 ft.). Use a sensing edge to provide entrapment protection on doors over 35 ft. wide.
2. A sensing edge can be used on all doors without size restriction.

TYPES AND SIZES OF DOORS

HP	MAXIMUM AREA - SQ. FT.								
	Fire Doors			Insulated Fire Doors					
				24 ga Back			22 ga Back		
	22 ga	20 ga	18 ga	22 ga	20 ga	18 ga	22 ga	20 ga	18 ga
1/3	149	124	93	75	68	57	71	62	53

INSTALLATION INSTRUCTIONS

INSTALLATION POSITIONS

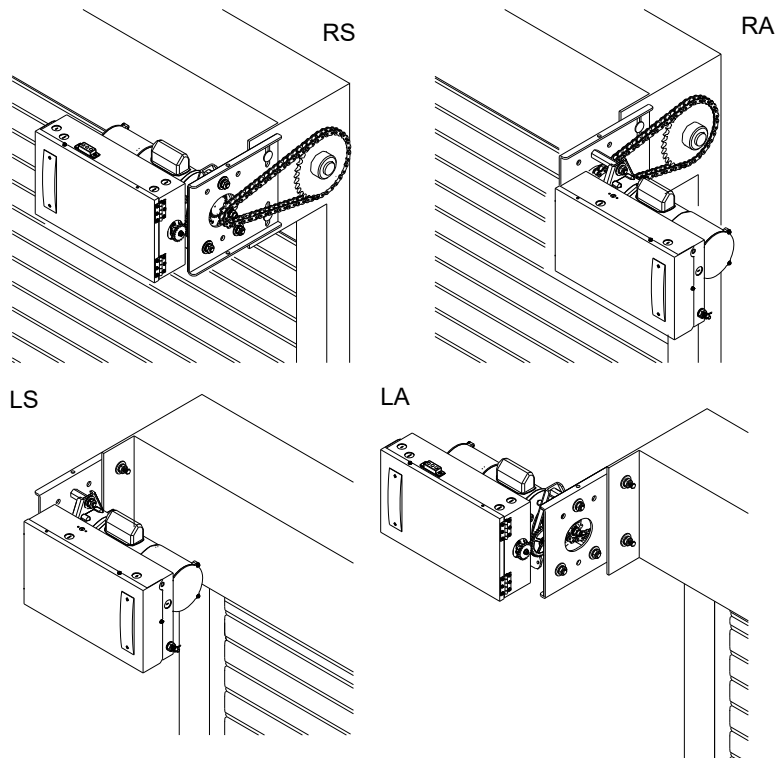

Consult factory for changes in installation positions.

NOTE: Any change in mounting position may result in a change of operator rotation and consequently in a change of control functions. Consult factory for any changes. (LS and RA mounting positions are LH operators, RS and LA positions are RH operators)

Operators mounted in alternate positions (LA, RA) require the long mounting legs in lieu of the standard short mounting legs.

OPERATOR MOUNTING

1. Before the operator is installed, verify that the door is properly operating and balanced.
2. Make sure the layout of the mounting holes on the bracket are correct.
3. Bolt the operator mounting plate to the door bracket plate.
4. Attach and tighten the three mounting legs to the mounting plate.
5. Mount the operator to the three legs and tighten.

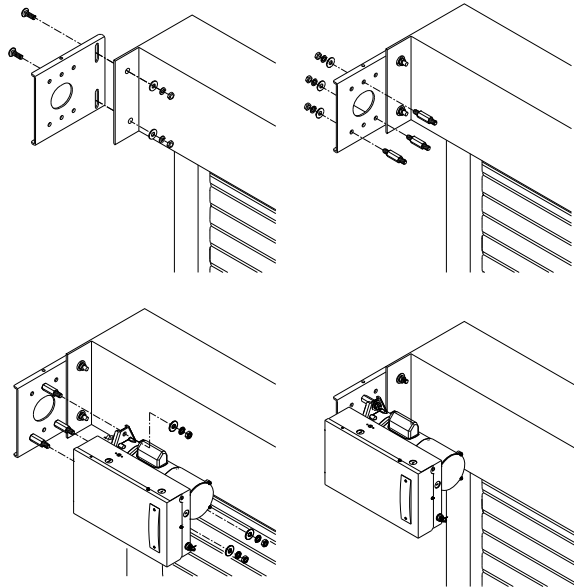

6. When the operator assembly is attached to the door bracket, be sure the door driven sprocket is properly aligned with the operator drive sprocket before securing the driven sprocket to the shaft.
7. The bracket must provide adequate support for the operator. Prevent play between the operator and the door shaft. The operator must be securely attached with the drive shaft parallel to the door shaft. It may be necessary to field brace the operator/bracket.

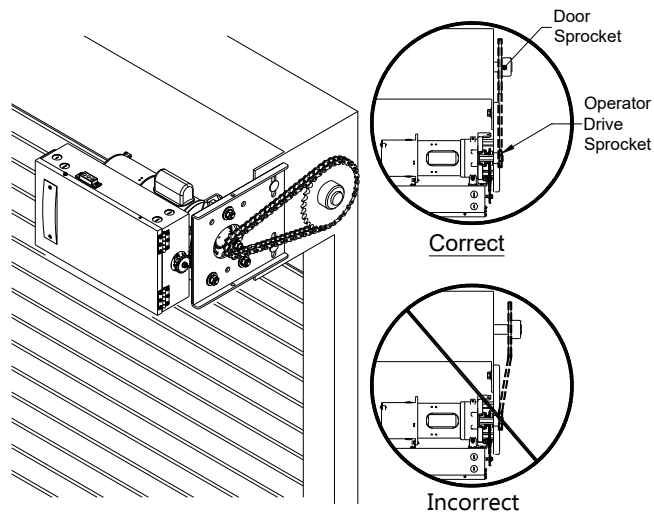

DRIVE CHAIN ADJUSTMENT

NOTE: Use correct type, size and proper length of roller chain.

1. Adjust the drive chain by tilting or move the operator so that there is about 1/4" of slack when the chain is depressed.

Note: The set screw included in the operator may be used for adjustment.

2. Once the drive chain has been tightened and the base leg screws have been set, and then tighten the operator screws.

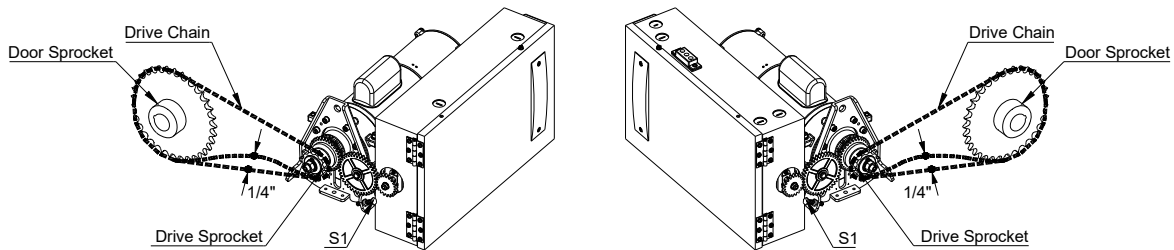

LIMIT SWITCH ADJUSTMENT

Make sure the limit cams are positioned between the limit switch actuators before proceeding with adjustments.

1. Open the control panel cover.
2. Open or close the door part way to determine the direction of travel of the limit switch cams.
3. Open or close the door to the desired position.



Disconnect power before adjusting limit switch cams.

WARNING

4. While pressing the spring-loaded plate (G), which holds the limit switch cams in place, adjust the limit switch cam (E or F) until the micro switch (C or D) clicking sound is heard.
5. If the limit switch cam cannot be rotated to its desired position, release the plate and move the door away from the desired position, then adjust the limit switch cam to its desired position. It may be necessary to repeat this step until the exact position has been reached.
6. Repeat step 3 and 4 for the opposite direction. Adjust close limit cams so that actuator is engaged as door fully closes to the floor.
7. "B" is usually the sensing edge cut-off switch and can be adjusted to accommodate sensing edge cut-off position. It is recommended that the switch position be adjusted as low as possible without interfering with close limit switch function.

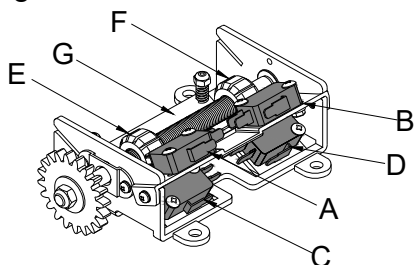

NOTE: "C" is usually the open limit switch and "D" is usually the close limit switch.

INTERNAL LOCK SENSOR

NOTE: All units with lock sensors are adjusted to the most sensitive level at the factory. A RED paint seal is applied on the lock sensor hex nut and shaft. Once the seal has been broken, interlock sensitivity has been changed. Door and /or door lock may be damaged.

Use the special tool provided to adjust the sensitivity of the lock sensor:

1. Loosen the hex nut.
2. Adjust the screw at the end of the operator drive shaft for sensitivity. Adjustment range is from 0 to 6 turns. More than 6 turns of adjustment could cause damage to the sensor assembly. More sensitivity will result in less pull against the locking device but less capacity to lift the door - less sensitivity will result in more pull against the locking device but more capacity to lift the door.
3. Tighten the hex nut.

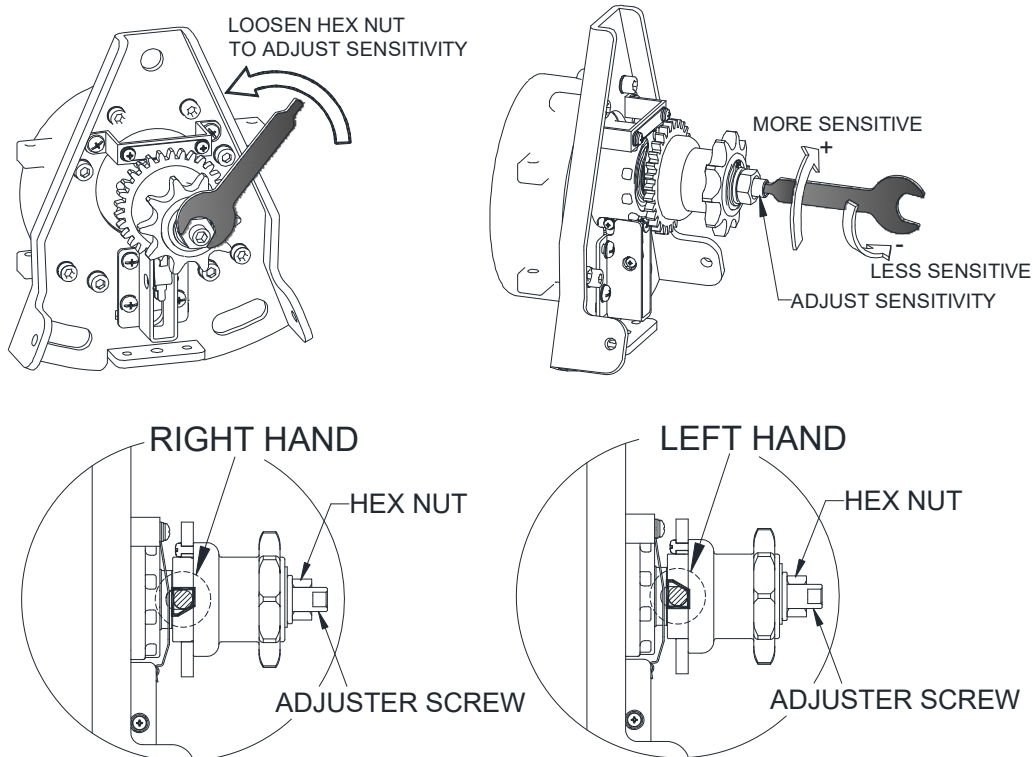

NOTE: 6 turns of the adjustment screw will result in the lock sensor having the least possible sensitivity, which means the greatest amount of pull against the locking device. If the door is still not functioning properly, check spring tension, overall door installation and consult the door manufacturer.

NOTE: The lock sensor is hand-sensitive. See illustrations for reference. Consult factory if the operator provided is not the correct hand.

WIRING INSTRUCTIONS



Disconnect power at the fuse box before proceeding with any wiring.

WARNING

1. Do not install any wiring or attempt to run this operator without checking the wiring diagram located on the inside of the control box cover.
2. Do not turn on power until you have finished making all power and control wiring connections.
3. Do not run power and control wiring in the same conduit.
4. Any wire connected to the control panel must be protected by conduit or other means to ensure the safety and permanency of the wiring.
5. Use copper wire inside the control panel.
6. A separate fuse line of adequate capacity is needed for the operator.
7. The operator must be properly grounded. The ground screw, painted green, is located inside the control panel.
8. For an operator, system, or external device requiring field installed wiring between a Class 2 output of an operator and an external device, the type of wiring shall be R/C (AVLV2/8), AWM, min. 22 AWG, rated 60°C, with VW-1/FT2.



WARNING

Failure to properly ground the operator could result in electric shock and death or serious injury.



WARNING

Unless the operator includes an internal lock sensing system, or external electrical interlocks are installed, remove or make all door locks inoperative, or secure locks in the unlocked position. Failure to disable the locks could result in damage to the door or operator.

CONTROL WIRING



WARNING

If the door is not visible from the control station, or if any device other than a control station requiring constant pressure to close the door is used, a monitored sensing device must be installed on the door. Failure to do so could result in serious injury or death to person(s) trapped beneath the door.

1. Complete limit switch adjustments before making any sensing edge/non-contact device wiring connections to the operator.

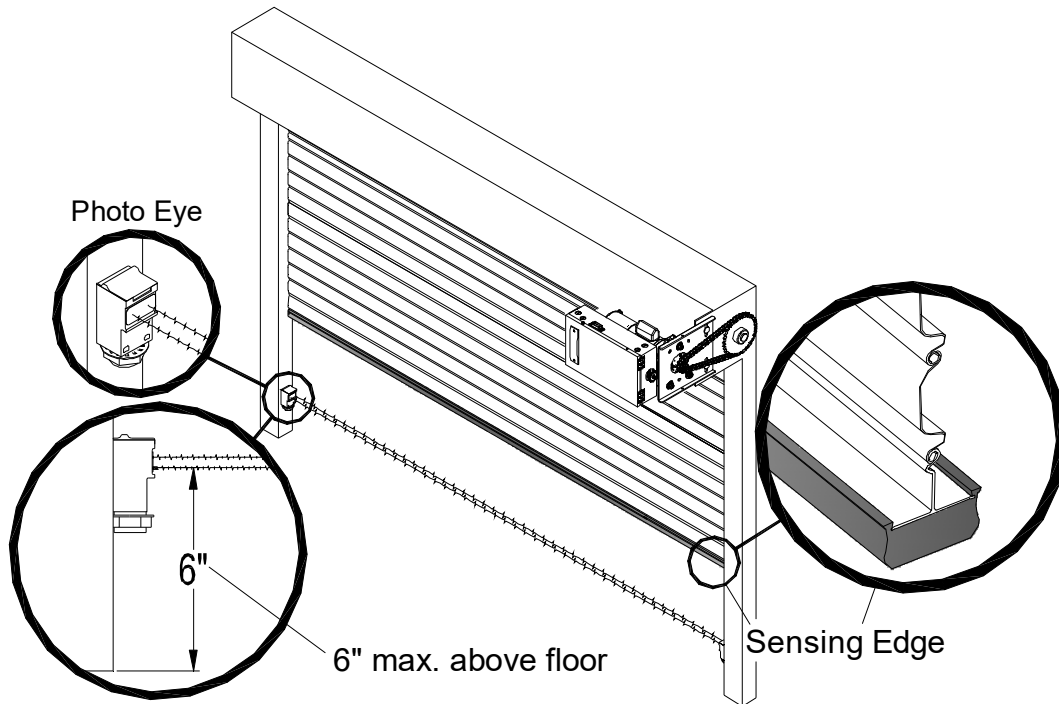

Monitored Sensing Device Options:

Sensing Device Type	Device Manufacturer	Model
ELR 2-wire terminated sensing edge	ASO	25.30TTLL [A2530L-M], 15.25TTL [A1525-M], 30.70TTLa [A3070L-M], GE245, GE F45, GE F50, GE F56, GE F65, GE F85, GE F115
	Miller Edge Inc. * Must have model number with Suffix T2.	ME110*, ME111*, ME120*, ME123*, ME112*, ME113*, ME116*, ME117*
		MT21*, MU21*, MT22*, MU22*, MC22*, MU33*, MC271*, CPT223*
		MEL-TXYY, MEL-RXYY RB-G-K10
IR Emitter/receiver reflective photo eyes and sensing edge	FRABA Inc.	Optical photo eyes and optical sensing edge, Models OPTOEYE [FOPE], OPTOEDGE; OSE, OPE, OSE-P, OSE-R, OSE-T, RAY-N Reflective Photo Eye, Ray/RT -1004, -2004 [FRPE]
	Martec Access Products Inc.	1266
	Miller Edge Inc.	IG2, MIRM, MLC-K36, MLC-K72 RB-D-K10

Other approved devices may also be available – consult manufacturer for compatibility. [denotes Lawrence reference]

Note: Refer to sensing device manufacturer for specific installation and maintenance requirements.

2. If more than one monitored sensing device is to be used, each device must be connected to a separate ELR/IR sensing module to provide separate monitoring functions. Consult factory for a multiple device adapter.



WARNING

Do not install a timer to close the door unless some type of monitored entrapment protection device has been installed. Failure to do so may result in death or serious injury to person(s) trapped beneath the door.

3. If a timer to close (reclose timer) is to be used, a compatible reclose timer module is required that will not interfere with the monitoring of sensing device functions. Consult factory for the correct reclose timer module,



WARNING

Disconnect power at the fuse box before proceeding with any wiring.

4. Locate the control station at a minimum height of 5 feet above the floor, and where the user can clearly see the operation of the door. Mount the enclosed placard adjacent to or near the door.



WARNING

Controls shall be located far enough away from the door, or positioned such that the user is prevented from coming in contact with the door, while operating the controls.

5. Do not run control wiring in the same conduit as power wiring.
6. Any wires connected to the control panel must be protected by conduit or other means to ensure the safety and permanency of the wiring.



WARNING

Do not install radio controls (receiver/transmitter) to operate the door unless some type of monitored entrapment protection device has been installed. Failure to do so may result in death or serious injury to person(s) trapped beneath the door.



WARNING

Changing from left hand to right hand or vice versa could result in change of control wiring. Consult factory for details.

7. After installation, be sure that the operator, controls, and sensing edge or other entrapment protection devices have been tested and function properly.

A. Control Function:

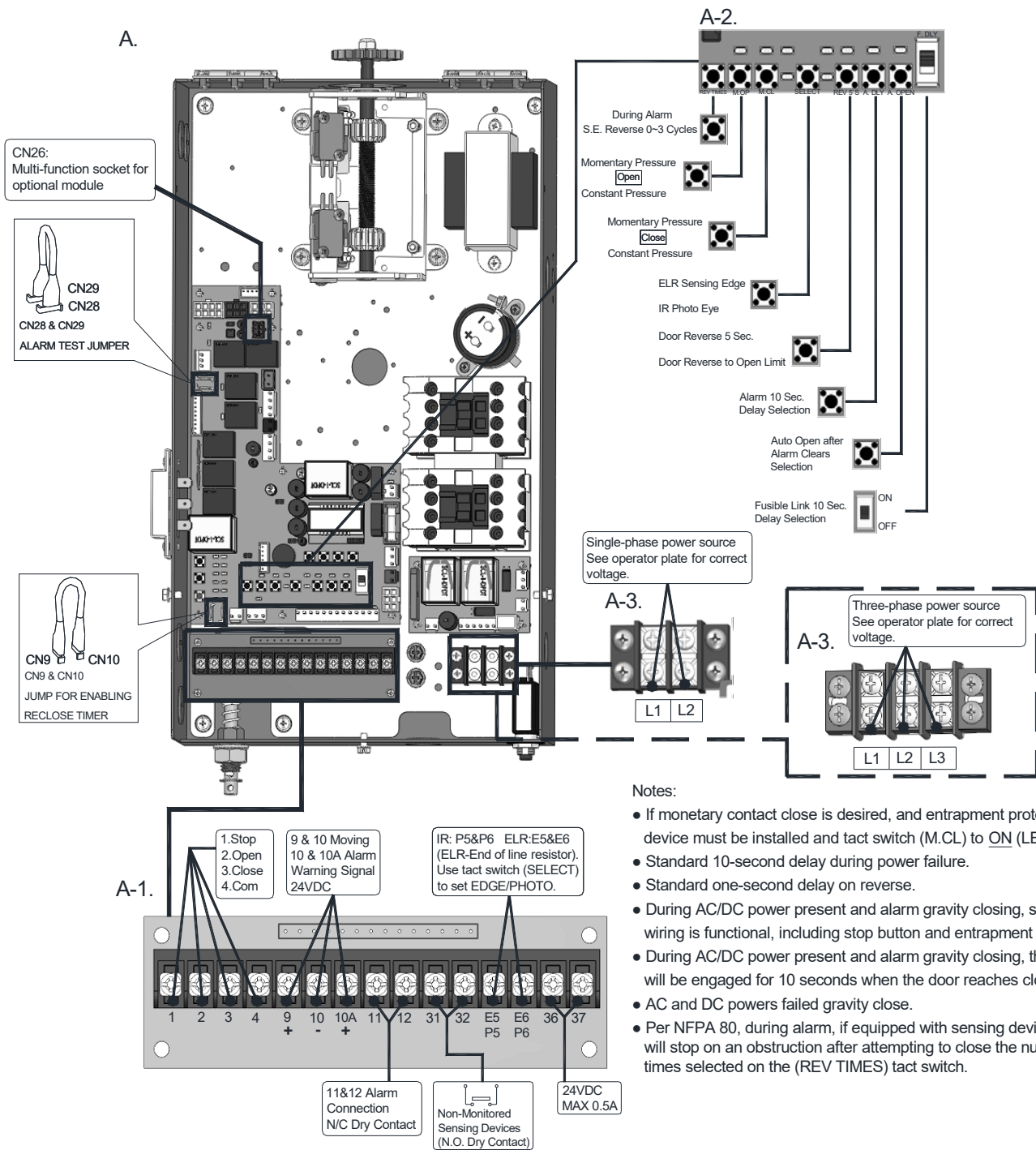

Notes:

- If monetary contact close is desired, and entrapment protection device must be installed and tact switch (M.CL) to **ON** (LED 12 lits).
- Standard 10-second delay during power failure.
- Standard one-second delay on reverse.
- During AC/DC power present and alarm gravity closing, safety wiring is functional, including stop button and entrapment device(s).
- During AC/DC power present and alarm gravity closing, the brake will be engaged for 10 seconds when the door reaches close limit.
- AC and DC powers failed gravity close.
- Per NFPA 80, during alarm, if equipped with sensing device, door will stop on an obstruction after attempting to close the number of times selected on the (REV TIMES) tact switch.

B. Auxiliary Function:

B-2. Radio control

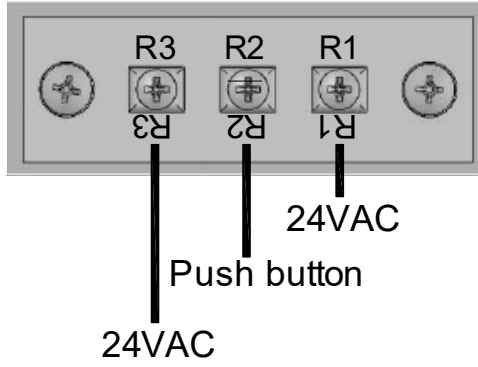

B-1.

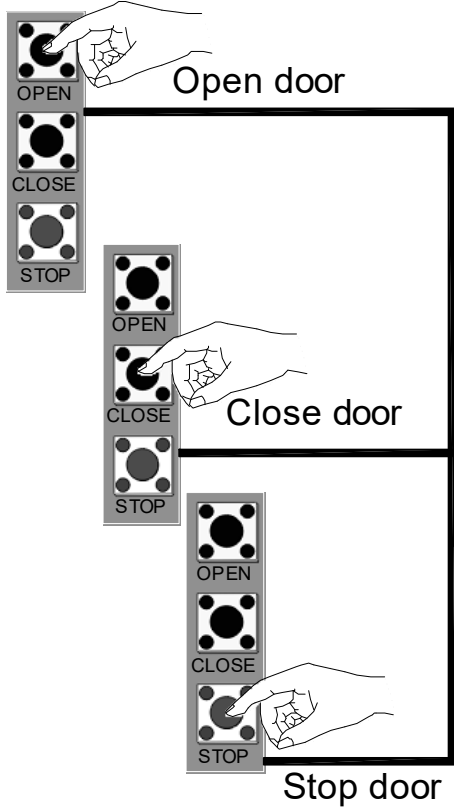

B.

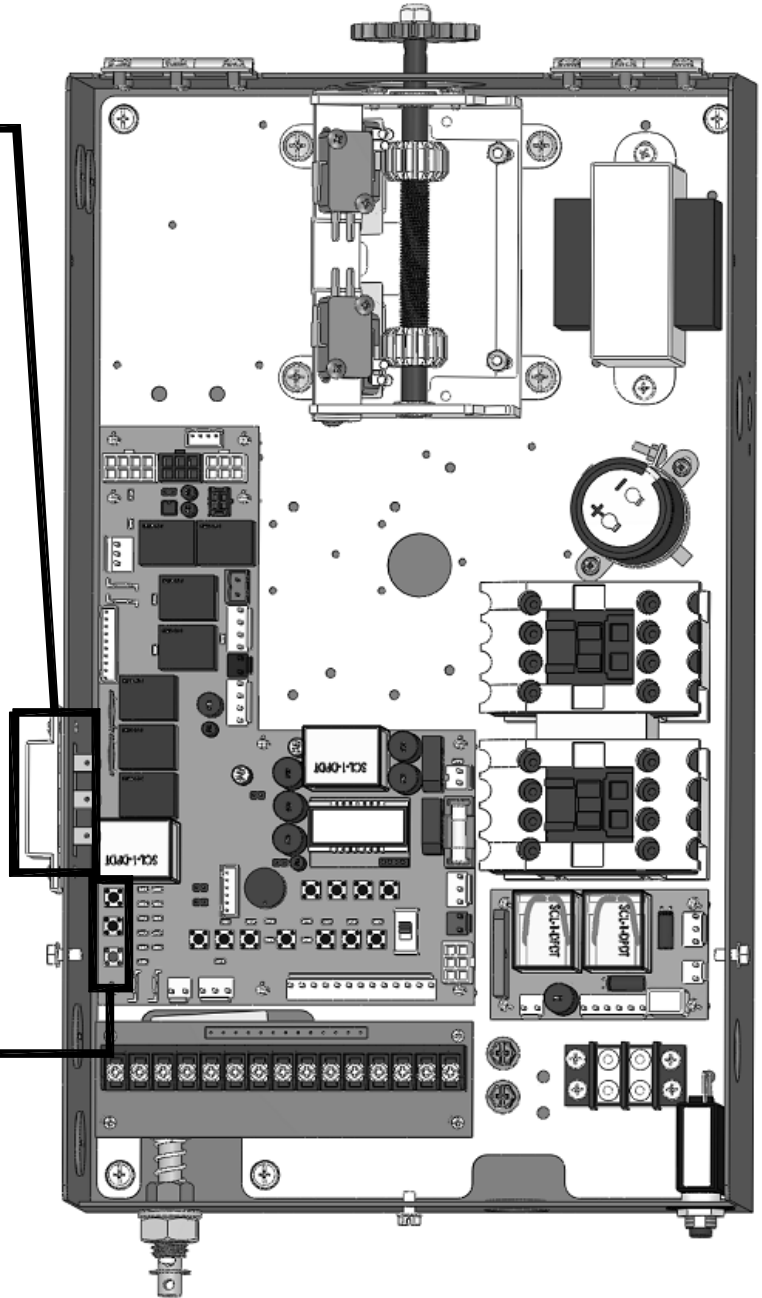

C. Timer Instruction:

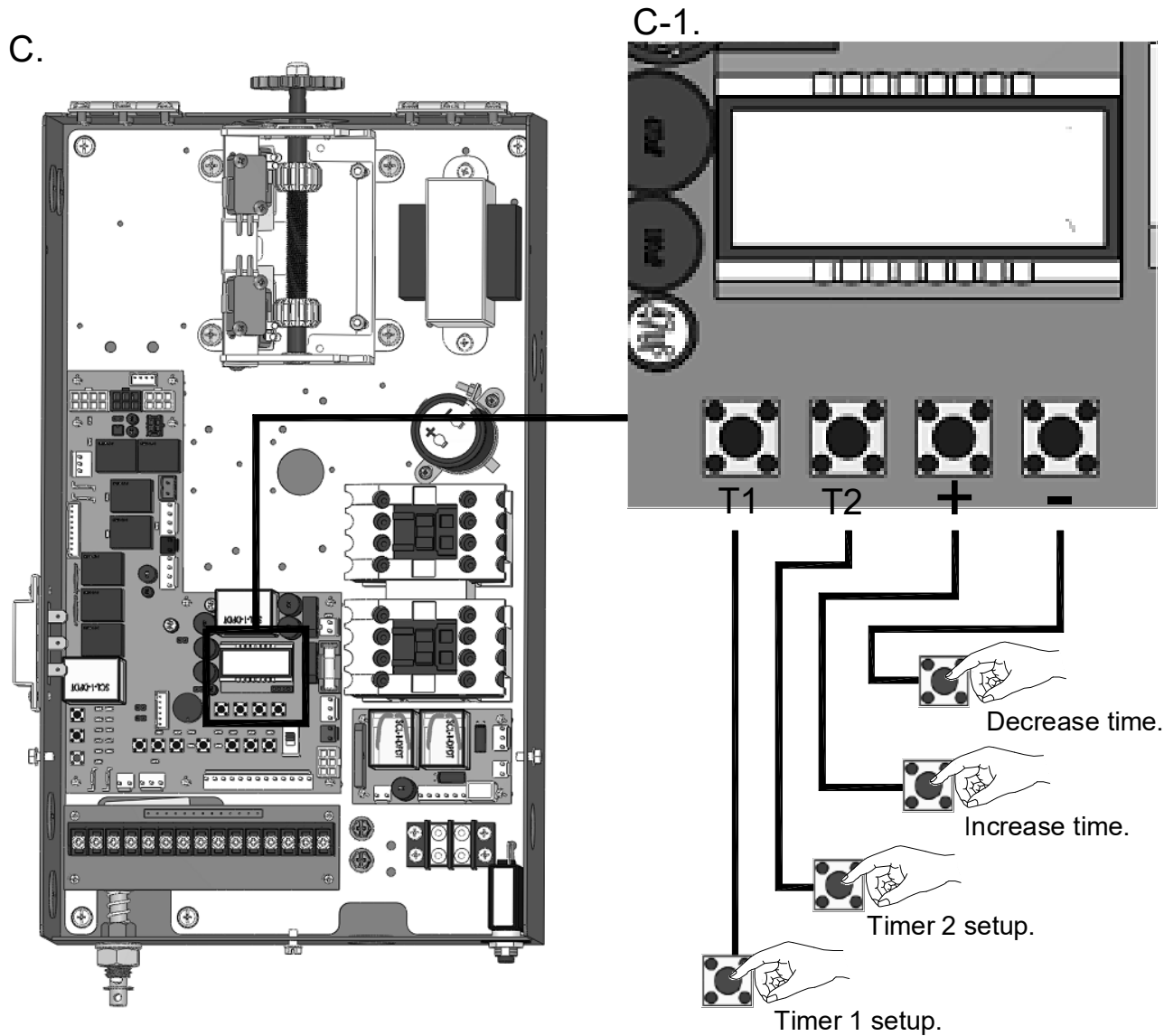





(1) Timer 1 – Mid-open timer: Timer starts counting when door leaves close limit. Door stops after opening for set time. Pressing open again at mid-open position will cause door to open limit.

Timer 2 – Close timer: Timer is active when door stops and is not at close limit.



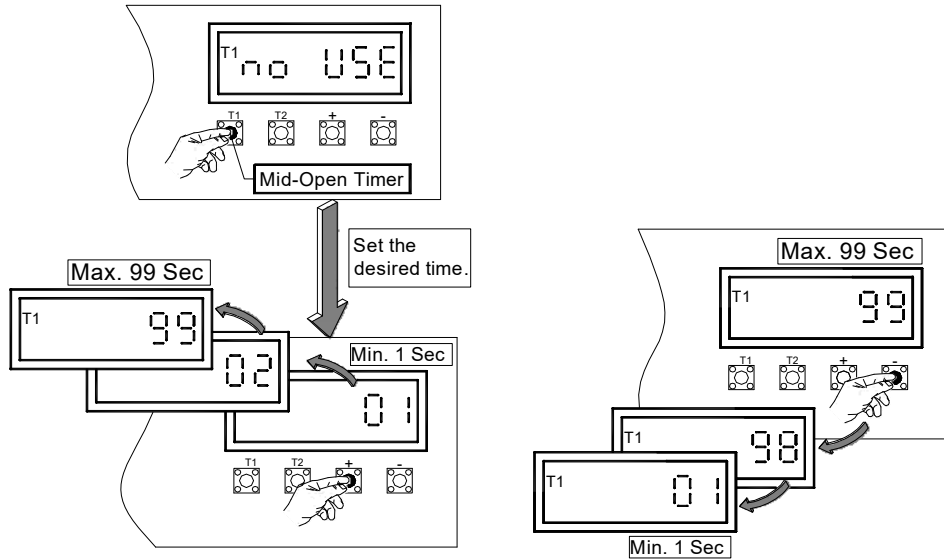

(2) Standard Mode: Cycle counter

(3) To Set Timer 1 (Mid-open Timer):

- Press  and hold for 5 seconds. Display will flash.
- Use  or  to increase or to decrease time.
- Press  to save setting. Without pressing, no adjustment is saved.







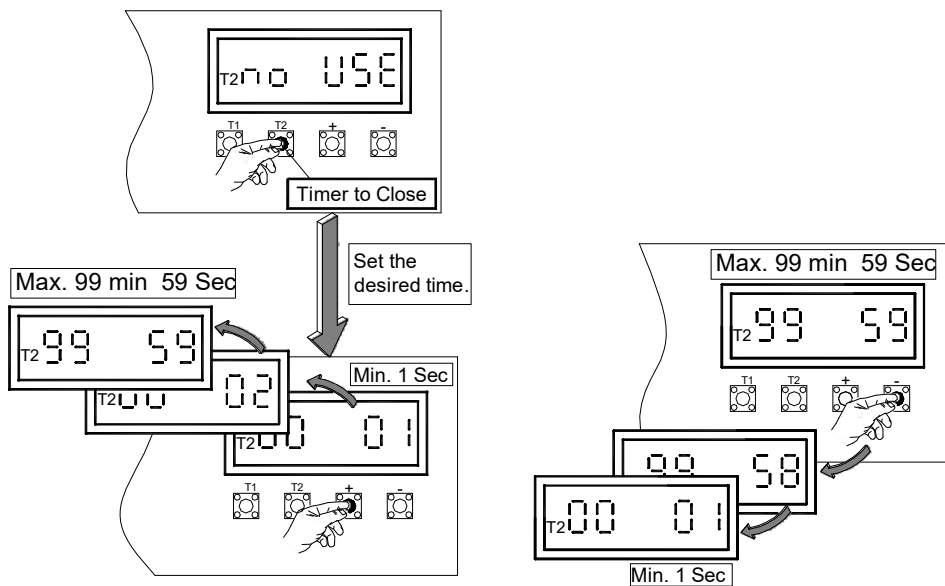

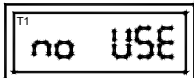

(4) To Set Timer 2 (Reclose Timer):

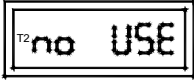
- Press  and hold for 5 seconds. Display will flash.
- Use  or  to increase or to decrease time.
- Press  to save setting. Without pressing, no adjustment is saved.

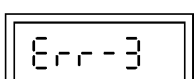
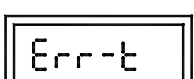
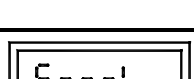

D. LCD Display Instruction:

Display	Status	Display	Status
	T1 setting		Door closing
	T2 setting		Door opening
	T1 or T2 setting completed		Alarm condition
	Limit switches don't response or respond both limits reached in standby or running period.		Two host controllers are setting at the same time.
	Connection interruption		Limit switch on client controller is abnormal.

E. Light Indication:

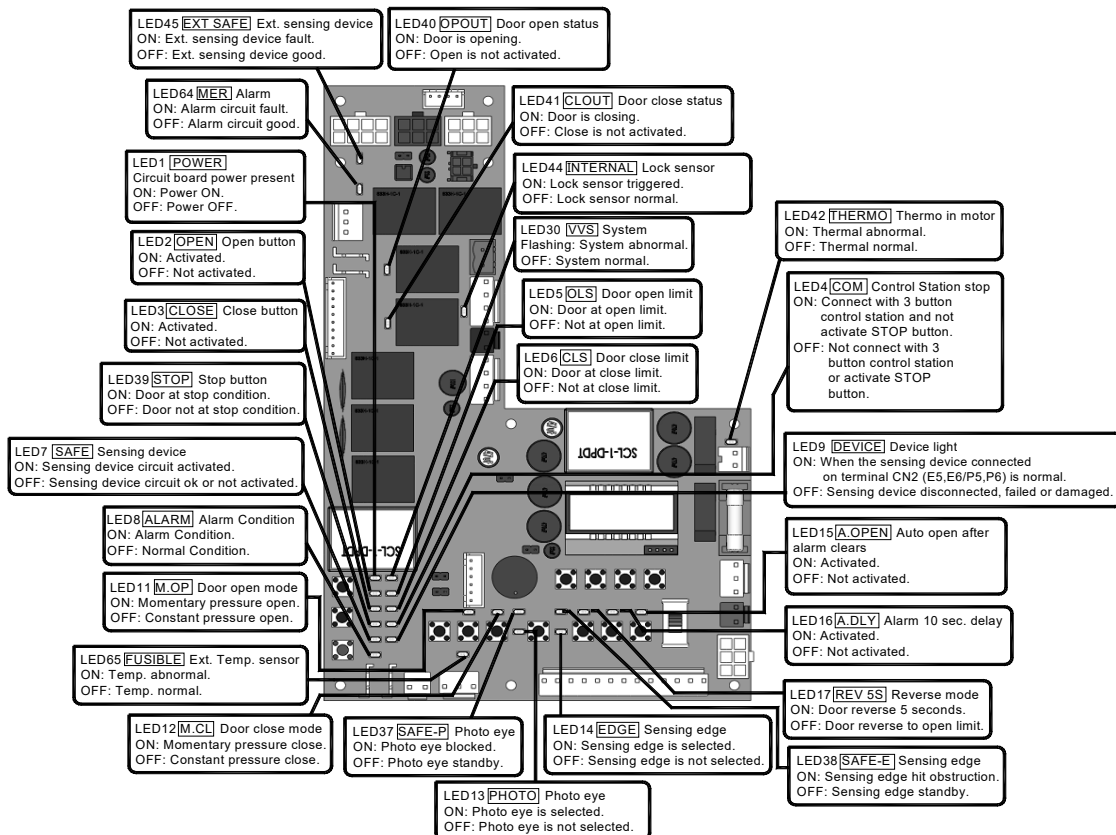

F. Sound Warnings:

Item	Description	Sound
A	Alarm warning signal	B _ _ _ B _ _ _ B _ _ _ B _ _ _
B	Terminal CN2 (1,4) not connected	B.B.B.B. B.B.B.B. B.B.B.B.

FSML 115V 1 PHASE 50/60HZ LH (EP BOARD)
(FOR FSML-31EP)

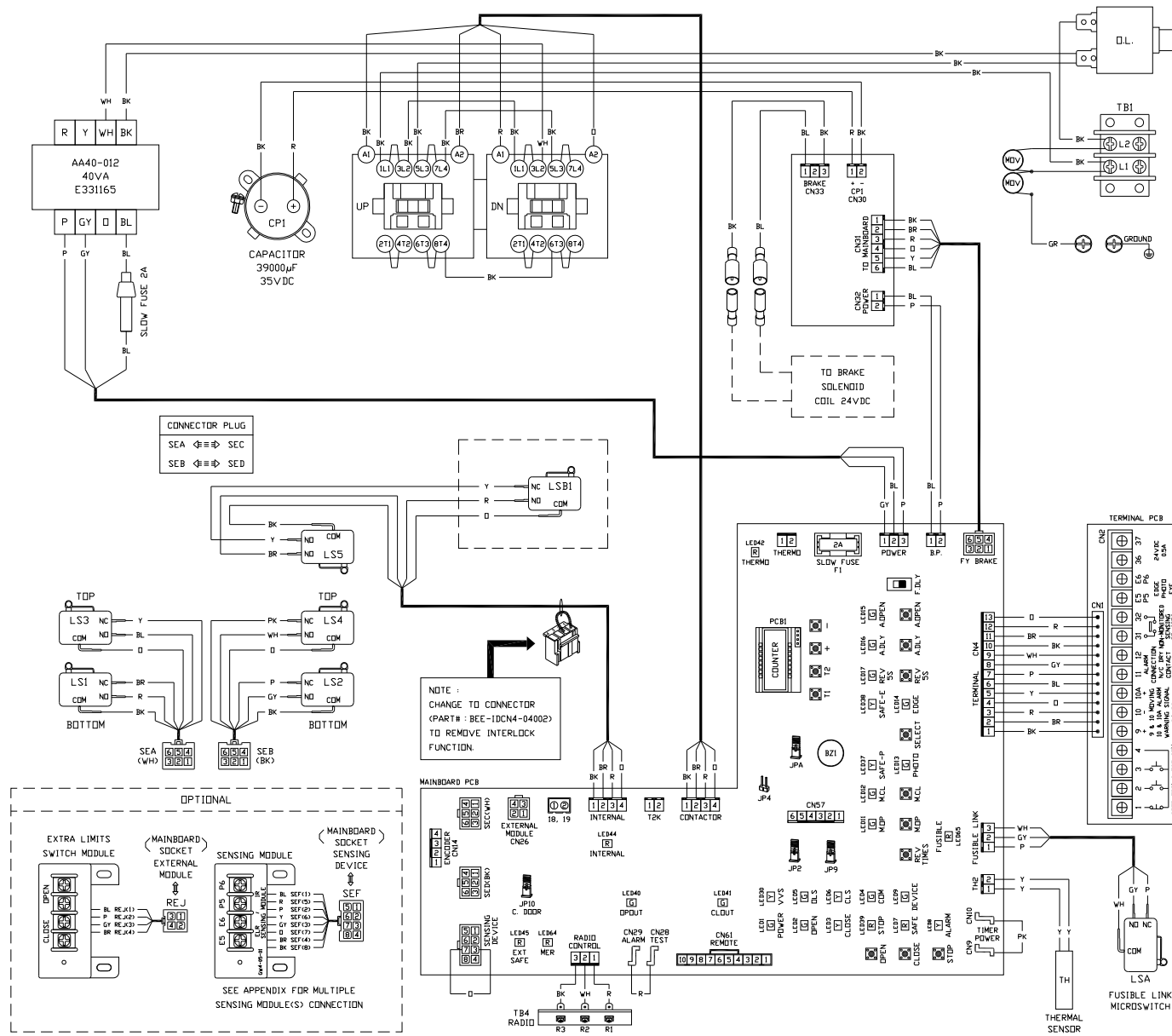

EBML 101EP L

- NOTES :
- MOV-TNR 14V 47K
 - CPI-CAPACITOR 39000µF 35VDC
 - SEA-LS1 & LS3 MICROSWITCH CONNECTOR.
 - SEB-LS2 & LS4 MICROSWITCH CONNECTOR.
 - LSA-FUSIBLE LINK MICROSWITCH.
 - LSS-INTERNAL INTERLOCK MICROSWITCH.
 - LSBI-INTERNAL INTERLOCK MICROSWITCH.
 - TH-THERMAL SENSOR.

- MAINBOARD PCB :
- SEC-OPEN CONTROL CONNECTOR.
 - SEC-CLOSE CONTROL CONNECTOR.
 - SENSING DEVICE-SENSING MODULE CONNECTOR.
 - T2K-24VDC OUTPUT FOR T2000 MAGNETIC POWER.
 - 18,19-EXTERNAL POWER INPUT 24VAC/DC.
 - EXTERNAL MODULE-OPTIONAL EXTRA OPEN AND CLOSE LIMITS CONNECTOR.
 - ALARM TEST-ALARM TEST JUMPER.
 - TIMER POWER-JUMP FOR ENABLING RECLOSE TIMER.
 - TH2-TEMPERATURE SENSOR.
 - BZ1-SOUND PATTERN REFER TO 'F. SOUND WARNINGS' IN THE MANUAL.
 - TI & T2-SEE INSTRUCTION MANUAL FOR DETAIL.
 - F. DLY-FUSIBLE LINK DELAY 10 SEC.
 - A. OPEN-AUTO OPEN AFTER ALARM CLEARS.
 - A. DLY-ALARM DELAY 10 SEC.
 - REV 5S-REVERSE TO OPEN LIMIT OR REVERSE 5 SEC.
 - SELECT-EDGE/PHOTO EYE SENSING DEVICE SELECTION.
 - M. CL-MOMENTARY/CONSTANT PRESSURE CLOSE.
 - M. DP-MOMENTARY/CONSTANT PRESSURE OPEN.
 - REV TIMES-HIT & REVERSE CYCLES.
 - JPA-DO NOT REMOVE, INTERNAL USE.
 - JP2-OPEN AND CLOSE WARNING SIGNAL (JUMPED). REMOVE JUMPER FOR CLOSE WARNING SIGNAL ONLY.
 - JP4-RESERVED, INTERNAL USE.
 - JP9-DO NOT REMOVE, INTERNAL USE.
 - JP10-BRAKE ENGAGE / DIS-ENGAGE AT CLOSE LIMIT POSITION.

- TERMINAL PCB - CN2 :
- CONTROL STATION-STOP
 - CONTROL STATION-OPEN
 - CONTROL STATION-CLOSE
 - CONTROL STATION-COMMON
- 9810 MOVING WARNING SIGNAL 24VDC
10810A ALARM WARNING SIGNAL 24VDC
11812 ALARM CONNECTION N/C DRY CONTACT
31832 NON-MONITORED SENSING DEVICES (N.O. DRY CONTACT)
E58E6/PS8P6 SENSING DEVICE CONNECTION
36&37 24VDC POWER, MAX. 0.5A

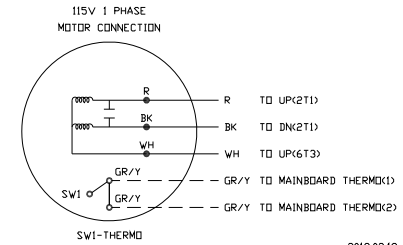

FSML 115V 1 PHASE 50/60HZ RH (EP BOARD)
(FOR FSML-31EP)

EBML 101EP R

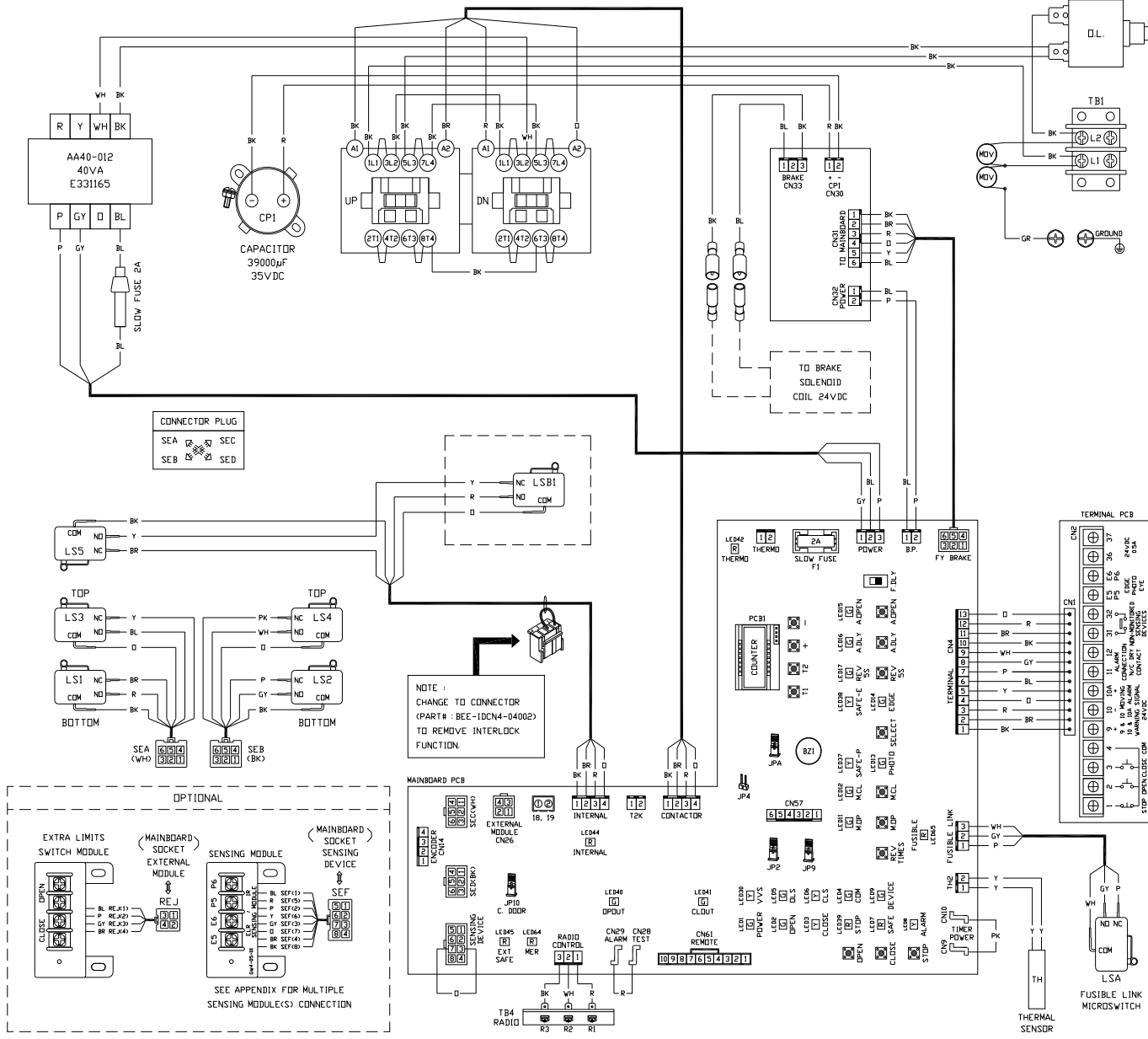

- NOTES :
1. MDV-TMR 14V 47K
 2. CPI-CAPACITOR 39000µF 35VDC
 3. SEA-LS1 & LS3 MICROSWITCH CONNECTOR.
 4. SEB-LS2 & LS4 MICROSWITCH CONNECTOR.
 5. LSA-FUSIBLE LINK MICROSWITCH.
 6. LSS-INTERNAL INTERLOCK MICROSWITCH.
 7. LSB1-INTERNAL INTERLOCK MICROSWITCH.
 8. TH-THERMAL SENSOR.
- MAINBOARD PCB :
1. SEC-OPEN CONTROL CONNECTOR.
 2. SEC-CLOSE CONTROL CONNECTOR.
 3. SENSING DEVICE-SENSING MODULE CONNECTOR.
 4. T2K-24VDC OUTPUT FOR T2000 MAGNETIC POWER.
 5. I8,I9-EXTERNAL POWER INPUT 24VAC/DC.
 6. EXTERNAL MODULE-OPTIONAL EXTRA OPEN AND CLOSE LIMITS CONNECTOR.
 7. ALARM TEST-ALARM TEST JUMPER.
 8. TIMER POWER-JUMP FOR ENABLING RECLOSE TIMER.
 9. TH2-TEMPERATURE SENSOR.
 10. BZ1-SOUND PATTERN REFER TO 'F. SOUND WARNINGS' IN THE MANUAL.
 11. T1 & T2-SEE INSTRUCTION MANUAL FOR DETAIL.
 12. F. DLY-FUSIBLE LINK DELAY 10 SEC.
 13. A. OPEN-AUTO OPEN AFTER ALARM CLEARS.
 14. A. DLY-ALARM DELAY 10 SEC.
 15. REV 5S-REVERSE TO OPEN LIMIT OR REVERSE 5 SEC.
 16. SELECT-EDGE/PHOTO EYE SENSING DEVICE SELECTION.
 17. M. CL-MOMENTARY/CONSTANT PRESSURE CLOSE.
 18. M. DP-MOMENTARY/CONSTANT PRESSURE OPEN.
 19. REV TIMES-HIT & REVERSE CYCLES.
 20. JPA-DO NOT REMOVE, INTERNAL USE.
 21. JP2-OPEN AND CLOSE WARNING SIGNAL (JUMPED). REMOVE JUMPER FOR CLOSE WARNING SIGNAL ONLY.
 22. JP4-RESERVED, INTERNAL USE.
 23. JP9-DO NOT REMOVE, INTERNAL USE.
 24. JP10-BRAKE ENGAGE / DIS-ENGAGE AT CLOSE LIMIT POSITION.
- TERMINAL PCB - CN2 :
- 1 CONTROL STATION-STOP
 - 2 CONTROL STATION-OPEN
 - 3 CONTROL STATION-CLOSE
 - 4 CONTROL STATION-COMMON
 - 9&10 MOVING WARNING SIGNAL 24VDC
 - 10&10A ALARM WARNING SIGNAL 24VDC
 - 11&12 ALARM CONNECTION N/C DRY CONTACT
 - 31&32 NON-MONITORED SENSING DEVICES (N.O. DRY CONTACT)
 - E5&E6/P5&P6 SENSING DEVICE CONNECTION
 - 36&37 24VDC POWER, MAX. 0.5A

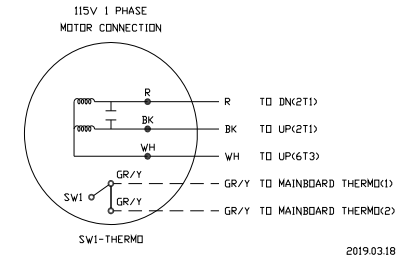

2019.03.18

FSML 230V 1 PHASE 50/60HZ LH (EP BOARD)

(60HZ FOR FSML-32EP)

(50HZ FOR FSML-35EP)

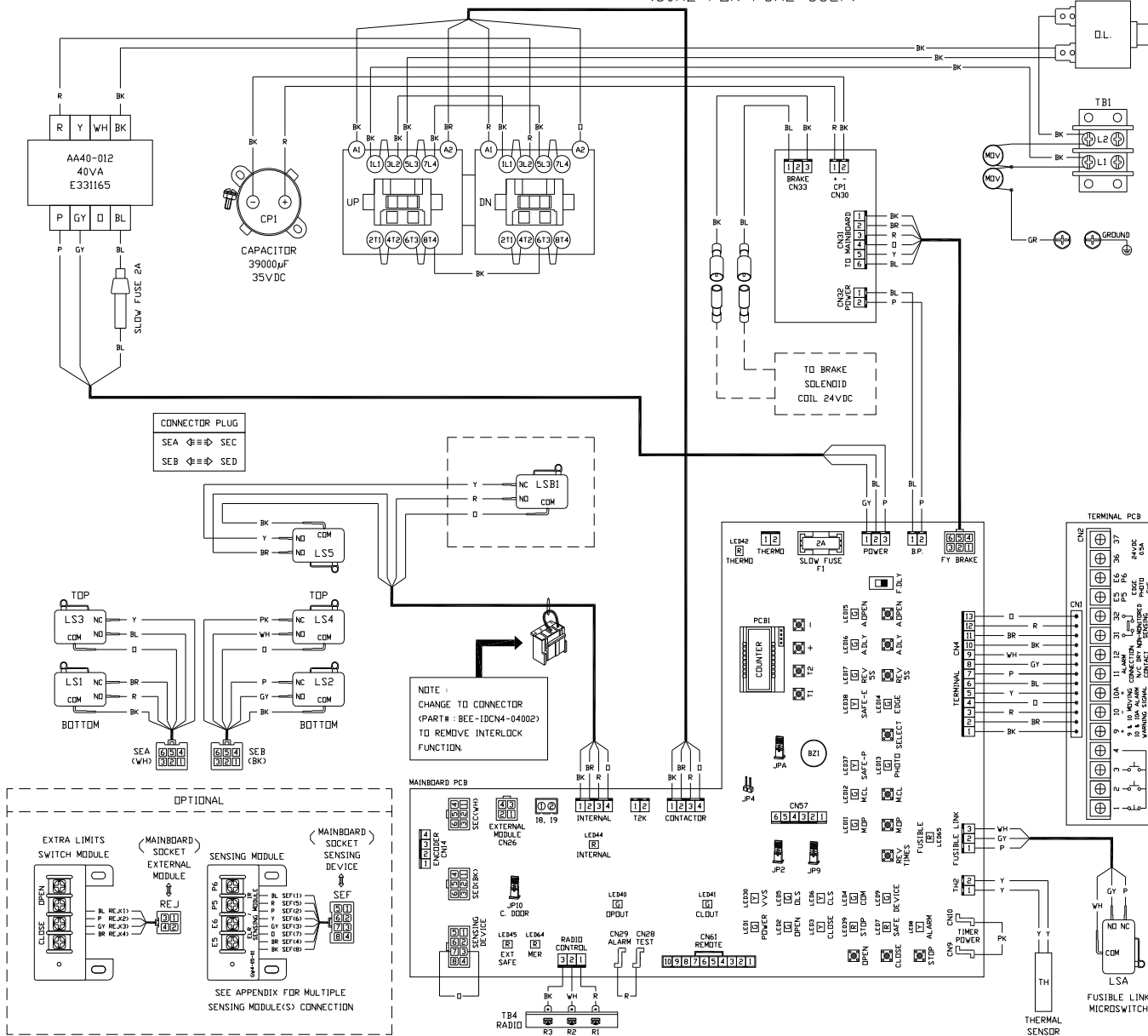

EBML 201EP L

- NOTES :
1. MOV-TNR 14V 47K
 2. CPI-CAPACITOR 39000µF 35VDC
 3. SEA-LS1 & LS3 MICROSWITCH CONNECTOR.
 4. SEB-LS2 & LS4 MICROSWITCH CONNECTOR.
 5. LSA-FUSIBLE LINK MICROSWITCH.
 6. LS5-INTERNAL INTERLOCK MICROSWITCH.
 7. LSBI-INTERNAL INTERLOCK MICROSWITCH.
 8. TH-THERMAL SENSOR.
- MAINBOARD PCB :
1. SEC-OPEN CONTROL CONNECTOR.
 2. SEC-CLOSE CONTROL CONNECTOR.
 3. SENSING DEVICE-SENSING MODULE CONNECTOR.
 4. T2K-24VDC OUTPUT FOR 12000 MAGNETIC POWER.
 5. 18,19-EXTERNAL POWER INPUT 24VAC/DC.
 6. EXTERNAL MODULE-OPTIONAL EXTRA OPEN AND CLOSE LIMITS CONNECTOR.
 7. ALARM TEST-ALARM TEST JUMPER.
 8. TIMER POWER-JUMP FOR ENABLING RECLOSE TIMER.
 9. TH2-TEMPERATURE SENSOR.
 10. BZ1-SOUND PATTERN REFER TO 'F. SOUND WARNINGS' IN THE MANUAL.
 11. T1 & T2-SEE INSTRUCTION MANUAL FOR DETAIL.
 12. F. DLY-FUSIBLE LINK DELAY 10 SEC.
 13. A OPEN-AUTO OPEN AFTER ALARM CLEARS.
 14. A DLY-ALARM DELAY 10 SEC.
 15. REV SS-REVERSE TO OPEN LIMIT OR REVERSE 5 SEC.
 16. SELECT-EDGE/PHOTO EYE SENSING DEVICE SELECTION.
 17. M. CL-MOMENTARY/CONSTANT PRESSURE CLOSE.
 18. M. DP-MOMENTARY/CONSTANT PRESSURE OPEN.
 19. REV TIMES-HIT & REVERSE CYCLES.
 20. JPA-DO NOT REMOVE, INTERNAL USE.
 21. JP2-OPEN AND CLOSE WARNING SIGNAL (JUMPED). REMOVE JUMPER FOR CLOSE WARNING SIGNAL ONLY.
 22. JP4-RESERVED, INTERNAL USE.
 23. JP9-DO NOT REMOVE, INTERNAL USE.
 24. JP10-BRAKE ENGAGE / DIS-ENGAGE AT CLOSE LIMIT POSITION.

- TERMINAL PCB - CN2 :
- 1 CONTROL STATION-STOP
 - 2 CONTROL STATION-OPEN
 - 3 CONTROL STATION-CLOSE
 - 4 CONTROL STATION-COMMON
 - 9&10 MOVING WARNING SIGNAL 24VDC
 - 10&10A ALARM WARNING SIGNAL 24VDC
 - 11&12 ALARM CONNECTION N/C DRY CONTACT
 - 31&32 NON-MONITORED SENSING DEVICES (N.D. DRY CONTACT)
 - 5&6/PS&P6 SENSING DEVICE CONNECTION
 - 36&37 24VDC POWER, MAX. 0.5A

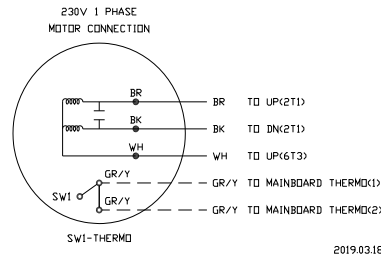

2019.03.18

FSML 230V 1 PHASE 50/60HZ RH (EP BOARD)
 (60HZ FOR FSML-32EP)
 (50HZ FOR FSML-35EP)

EBML 201EP R

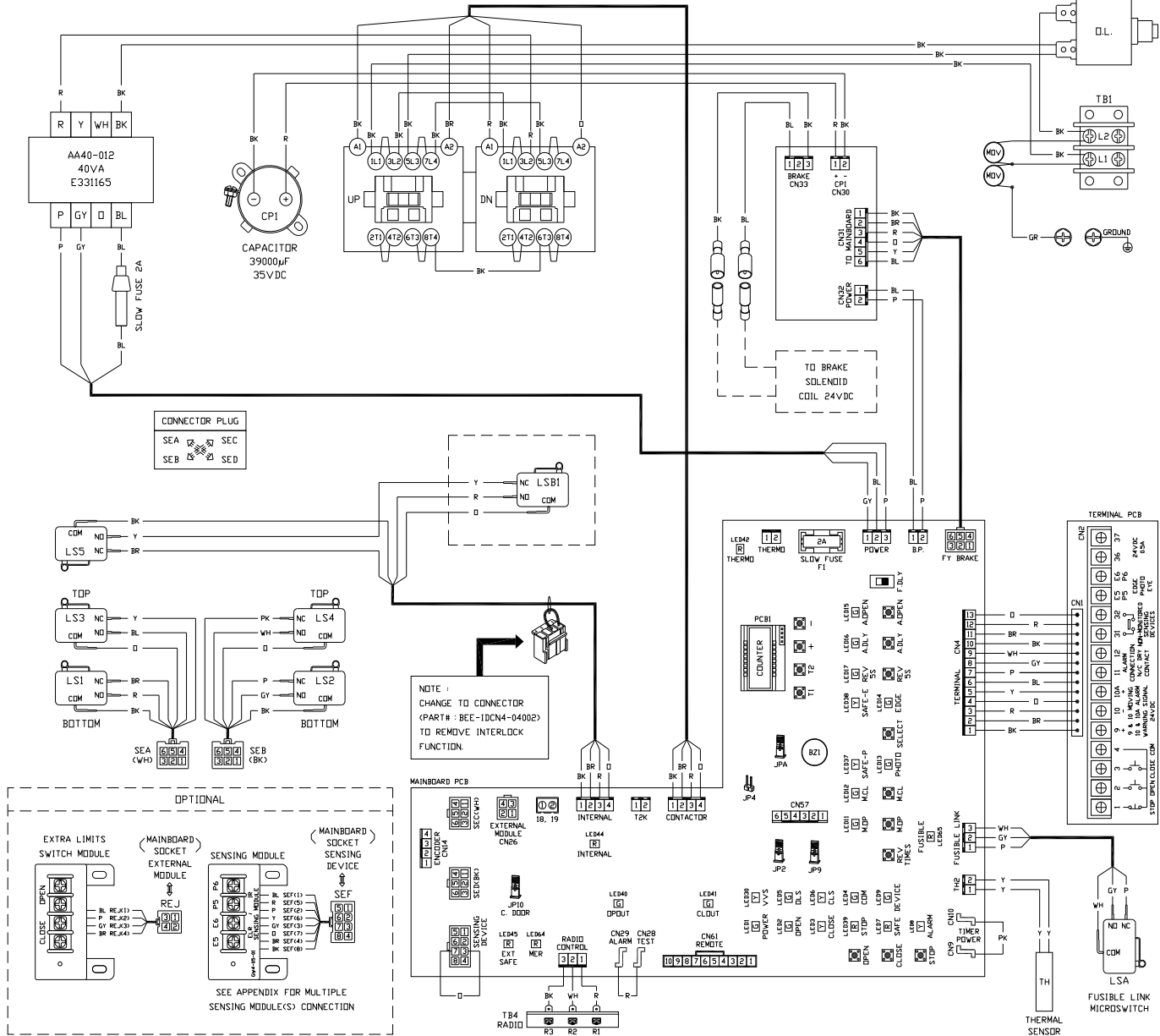

- NOTES :
1. MOV-TNR 14V 471K
 2. CP1-CAPACITOR 39000µF 35VDC
 3. SEA-LS1 & LS3 MICROSWITCH CONNECTOR.
 4. SEB-LS2 & LS4 MICROSWITCH CONNECTOR.
 5. LSA-FUSIBLE LINK MICROSWITCH.
 6. LSS-INTERNAL INTERLOCK MICROSWITCH.
 7. LSB1-INTERNAL INTERLOCK MICROSWITCH.
 8. TH-THERMAL SENSOR.

- MAINBOARD PCB :
1. SEC-OPEN CONTROL CONNECTOR.
 2. SEC-CLOSE CONTROL CONNECTOR.
 3. SENSING DEVICE-SENSING MODULE CONNECTOR.
 4. T2K-24VDC OUTPUT FOR T2000 MAGNETIC POWER.
 5. 18,19-EXTERNAL POWER INPUT 24VAC/DC.
 6. EXTERNAL MODULE-OPTIONAL EXTRA OPEN AND CLOSE LIMITS CONNECTOR.
 7. ALARM TEST-ALARM TEST JUMPER.
 8. TIMER POWER-JUMP FOR ENABLING RECLOSE TIMER.
 9. TH2-TEMPERATURE SENSOR.
 10. BZ1-SOUND PATTERN REFER TO 'F. SOUND WARNINGS' IN THE MANUAL.
 11. T1 & T2-SEE INSTRUCTION MANUAL FOR DETAIL.
 12. F. DLY-FUSIBLE LINK DELAY 10 SEC.
 13. A. OPEN-AUTO OPEN AFTER ALARM CLEARS.
 14. A. DLY-ALARM DELAY 10 SEC.
 15. REV SS-REVERSE TO OPEN LIMIT OR REVERSE 5 SEC.
 16. SELECT-EDGE/PHOTO EYE SENSING DEVICE SELECTION.
 17. M. CL-MOMENTARY/CONSTANT PRESSURE CLOSE.
 18. M. OP-MOMENTARY/CONSTANT PRESSURE OPEN.
 19. REV TIMES-HIT & REVERSE CYCLES.
 20. JPA-DD NOT REMOVE, INTERNAL USE.
 21. JP2-OPEN AND CLOSE WARNING SIGNAL (JUMPED). REMOVE JUMPER FOR CLOSE WARNING SIGNAL ONLY.
 22. JP4-RESERVED, INTERNAL USE.
 23. JP9-DD NOT REMOVE, INTERNAL USE.
 24. JP10-BRAKE ENGAGE / DIS-ENGAGE AT CLOSE LIMIT POSITION.

- TERMINAL PCB - CN2 :
- 1 CONTROL STATION-STOP
 - 2 CONTROL STATION-OPEN
 - 3 CONTROL STATION-CLOSE
 - 4 CONTROL STATION-COMMON
 - 9&10 MOVING WARNING SIGNAL 24VDC
 - 10&10A ALARM WARNING SIGNAL 24VDC
 - 11&12 ALARM CONNECTION N/C DRY CONTACT
 - 31&32 NON-MONITORED SENSING DEVICE (N.O. DRY CONTACT)
 - E5&E6/PS&P6 SENSING DEVICE CONNECTION
 - 36&37 24VDC POWER, MAX. 0.5A

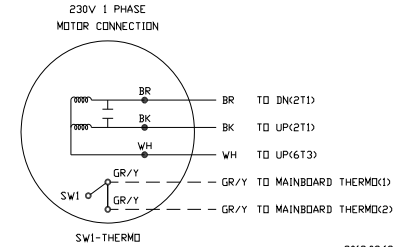

2019.03.18

FSML 208V/230V 3 PHASE 50/60HZ LH (EP BOARD)
(FOR FSML-33EP)

NOTE:
FOR 208V INPUT POWER
-REMOVE RED WIRE CONNECTOR AND
THEN CONNECT TO YELLOW WIRE.
-PROPERLY INSULATED THE RED WIRE.

EBML 301EP L

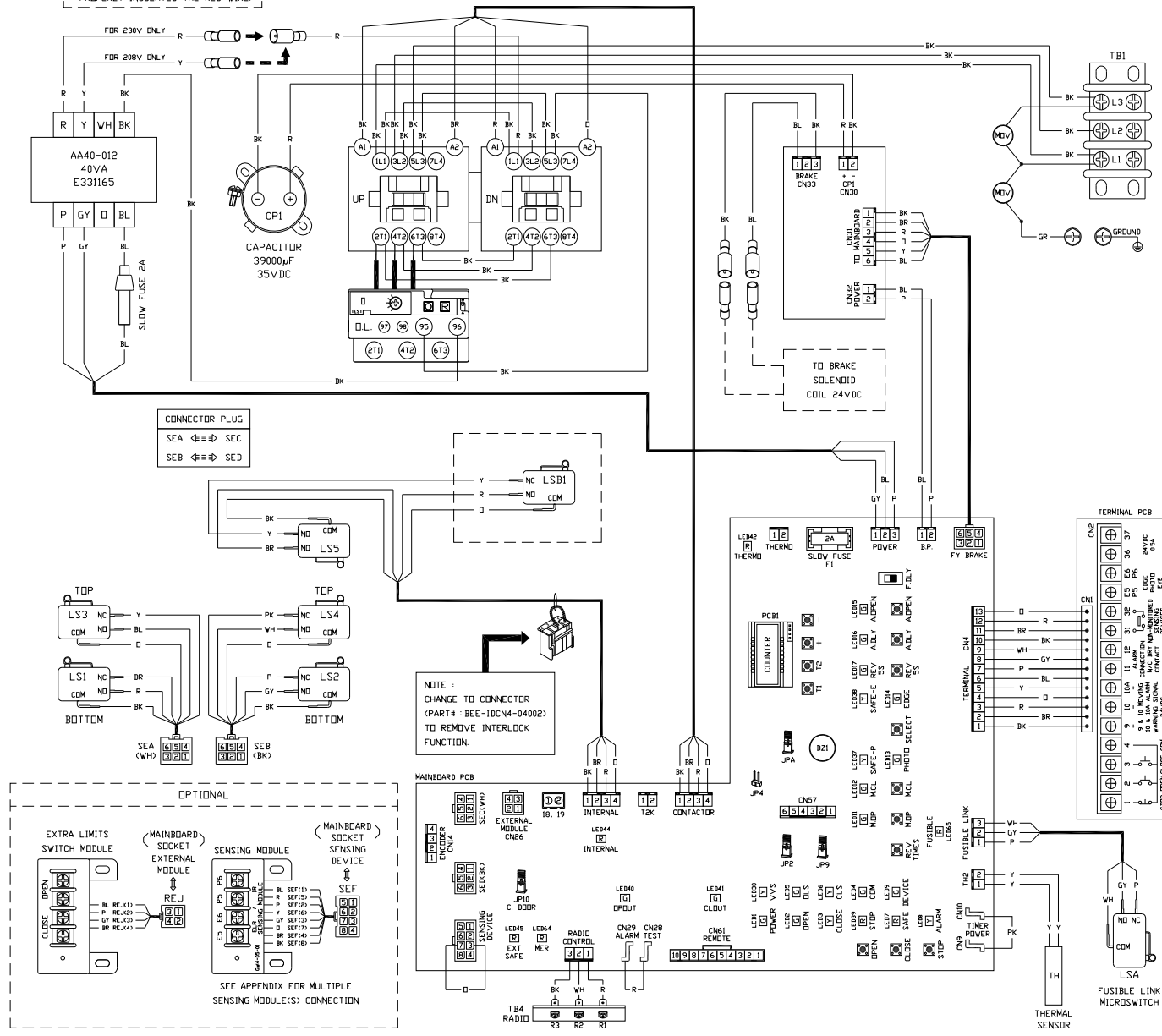

- NOTES :
- MOV-TNR 14V 471K
 - CP1-CAPACITOR 39000µF 35VDC
 - SEA-LS1 & LS3 MICROSWITCH CONNECTOR.
 - SEB-LS2 & LS4 MICROSWITCH CONNECTOR.
 - LSA-FUSIBLE LINK MICROSWITCH.
 - LS5-INTERNAL INTERLOCK MICROSWITCH.
 - LSBI-INTERNAL INTERLOCK MICROSWITCH.
 - TH-THERMAL SENSOR.

- MAINBOARD PCB :
- SEC-OPEN CONTROL CONNECTOR.
 - SEC-CLOSE CONTROL CONNECTOR.
 - SENSING DEVICE-SENSING MODULE CONNECTOR.
 - T2K-24VDC OUTPUT FOR T2000 MAGNETIC POWER.
 - 18,19-EXTERNAL POWER INPUT 24VAC/DC.
 - EXTERNAL MODULE-OPTIONAL EXTRA OPEN AND CLOSE LIMITS CONNECTOR.
 - ALARM TEST-ALARM TEST JUMPER.
 - TIMER POWER-JUMP FOR ENABLING RECLOSE TIMER.
 - TH2-TEMPERATURE SENSOR.
 - BZ1-SOUND PATTERN REFER TO 'F. SOUND WARNINGS' IN THE MANUAL.
 - T1 & T2-SEE INSTRUCTION MANUAL FOR DETAIL.
 - F. DLY-FUSIBLE LINK DELAY 10 SEC.
 - A. OPEN-AUTO OPEN AFTER ALARM CLEARS.
 - A. DLY-ALARM DELAY 10 SEC.
 - REV SS-REVERSE TO OPEN LIMIT OR REVERSE 5 SEC.
 - SELECT-EDGE/PHOTO EYE SENSING DEVICE SELECTION.
 - M. CL-MOMENTARY/CONSTANT PRESSURE CLOSE.
 - M. DP-MOMENTARY/CONSTANT PRESSURE OPEN.
 - REV TIMES-HIT & REVERSE CYCLES.
 - JP4-DO NOT REMOVE, INTERNAL USE.
 - JP2-OPEN AND CLOSE WARNING SIGNAL (JUMPED). REMOVE JUMPER FOR CLOSE WARNING SIGNAL ONLY.
 - JP4-RESERVED, INTERNAL USE.
 - JP9-DO NOT REMOVE, INTERNAL USE.
 - JP10-BRAKE ENGAGE / DIS-ENGAGE AT CLOSE LIMIT POSITION.

- TERMINAL PCB - CN2 :
- CONTROL STATION-STOP
 - CONTROL STATION-OPEN
 - CONTROL STATION-CLOSE
 - CONTROL STATION-COMMON
- 9810 MOVING WARNING SIGNAL 24VDC
10810A ALARM WARNING SIGNAL 24VDC
11812 ALARM CONNECTION N/C DRY CONTACT
31832 NON-MONITORED SENSING DEVICES (N.C. DRY CONTACT)
E58E6/PS8P6 SENSING DEVICE CONNECTION
36&37 24VDC POWER, MAX. 0.5A

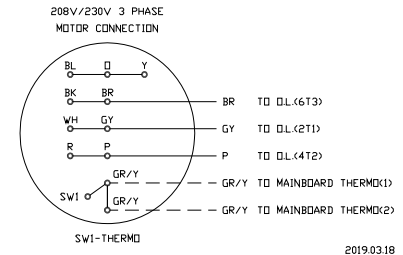

NOTE :
CHANGE TO CONNECTOR
(PART# : BEE-1DCM4-04002)
TO REMOVE INTERLOCK
FUNCTION.

CONNECTOR PLUG
SEA ♂=♂ SEC
SEB ♂=♂ SED

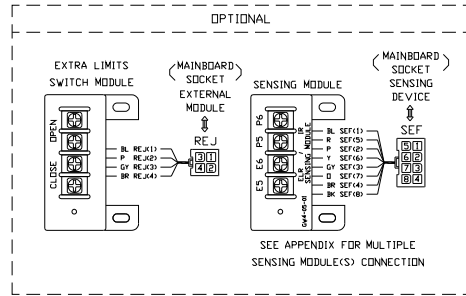
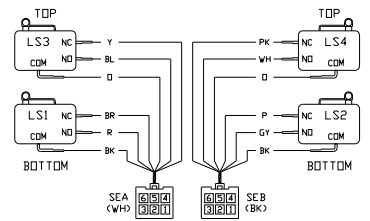

FSML 208V/230V 3 PHASE 50/60HZ RH (EP BOARD)
(FOR FSML-33EP)

NOTE:
FDR 208V INPUT POWER
• REMOVE RED WIRE CONNECTOR AND THEN CONNECT TO YELLOW WIRE.
• PROPERLY INSULATED THE RED WIRE.

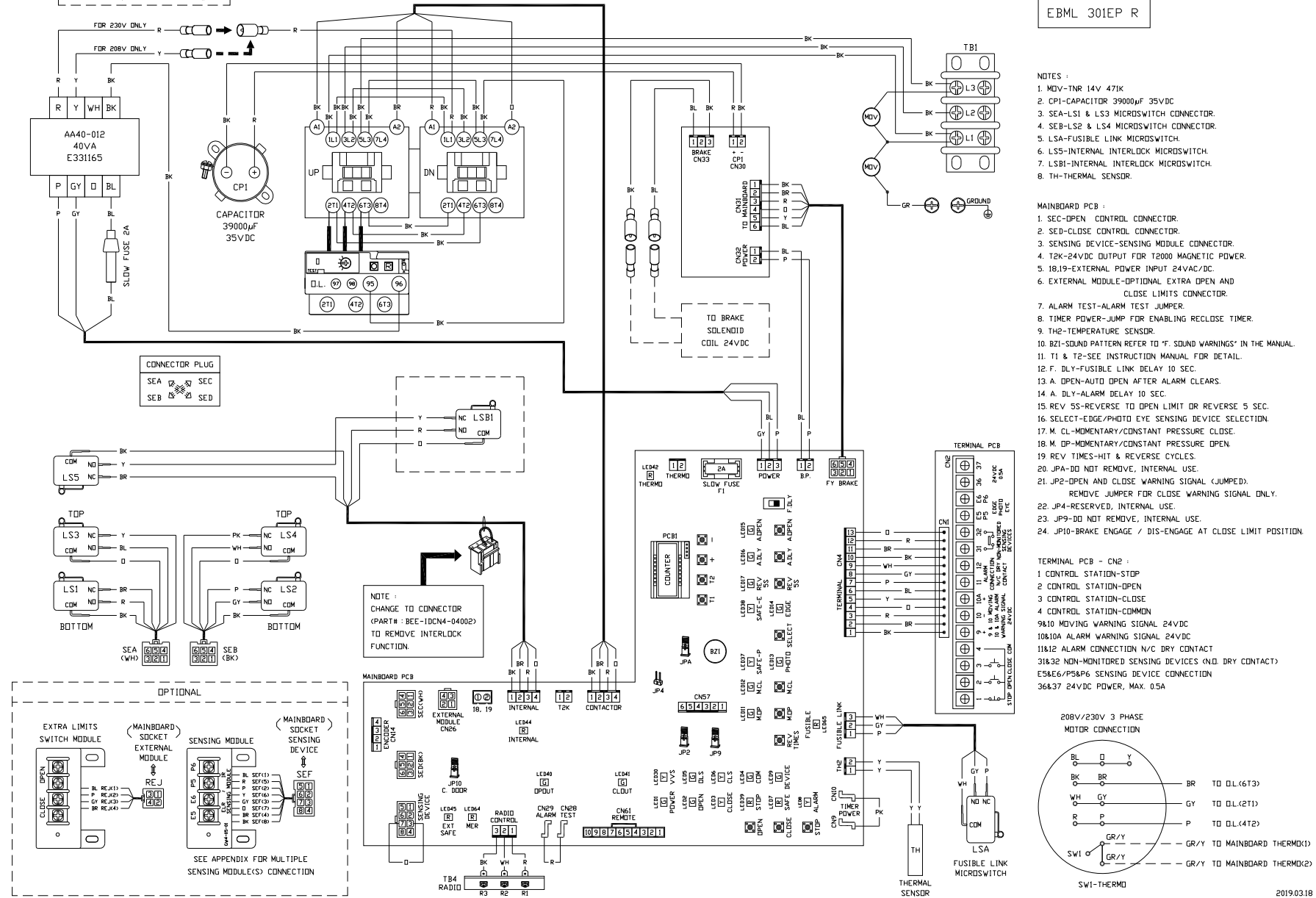

EBML 301EP R

- NOTES :**
- MOV-TNR 14V 471K
 - CPI-CAPACITOR 39000µF 35VDC
 - SEA-LS1 & LS3 MICROSWITCH CONNECTOR.
 - SEB-LS2 & LS4 MICROSWITCH CONNECTOR.
 - LSA-FUSIBLE LINK MICROSWITCH.
 - LS5-INTERNAL INTERLOCK MICROSWITCH.
 - LSB1-INTERNAL INTERLOCK MICROSWITCH.
 - TH-THERMAL SENSOR.
- MAINBOARD PCB :**
- SEC-OPEN CONTROL CONNECTOR.
 - SED-CLOSE CONTROL CONNECTOR.
 - SENSING DEVICE-SENSING MODULE CONNECTOR.
 - T2K-24VDC OUTPUT FOR T2000 MAGNETIC POWER.
 - 18,19-EXTERNAL POWER INPUT 24VAC/DC.
 - EXTERNAL MODULE-OPTIONAL EXTRA OPEN AND CLOSE LIMITS CONNECTOR.
 - ALARM TEST-ALARM TEST JUMPER.
 - TIMER POWER-JUMP FOR ENABLING RECLOSE TIMER.
 - TH2-TEMPERATURE SENSOR.
 - TH2-SOUND PATTERN REFER TO 'F. SOUND WARNINGS' IN THE MANUAL.
 - T1 & T2-SEE INSTRUCTION MANUAL FOR DETAIL.
 - F. DLY-FUSIBLE LINK DELAY 10 SEC.
 - A. OPEN-AUTO OPEN AFTER ALARM CLEARS.
 - A. DLY-ALARM DELAY 10 SEC.
 - REV 5S-REVERSE TO OPEN LIMIT OR REVERSE 5 SEC.
 - SELECT-EDGE/PHOTO EYE SENSING DEVICE SELECTION.
 - M. CL-MOMENTARY/CONSTANT PRESSURE CLOSE.
 - M. DP-MOMENTARY/CONSTANT PRESSURE OPEN.
 - REV TIMES-HIT & REVERSE CYCLES.
 - JPA-DO NOT REMOVE, INTERNAL USE.
 - JP2-OPEN AND CLOSE WARNING SIGNAL (JUMPED). REMOVE JUMPER FOR CLOSE WARNING SIGNAL ONLY.
 - JP4-RESERVED, INTERNAL USE.
 - JP9-DO NOT REMOVE, INTERNAL USE.
 - JP10-BRAKE ENGAGE / DIS-ENGAGE AT CLOSE LIMIT POSITION.
- TERMINAL PCB - CN2 :**
- CONTROL STATION-STOP
 - CONTROL STATION-OPEN
 - CONTROL STATION-CLOSE
 - CONTROL STATION-COMMON
- 9810 MOVING WARNING SIGNAL 24VDC
10810A ALARM WARNING SIGNAL 24VDC
11&12 ALARM CONNECTION N/C DRY CONTACT
31&32 NON-MONITORED SENSING DEVICES (NO DRY CONTACT)
E5&E6/P5&P6 SENSING DEVICE CONNECTION
36&37 24VDC POWER, MAX. 0.5A

FSML 460V 3 PHASE 50/60HZ LH (EP BOARD)
(FOR FSML-34EP)

EBML 401EP L

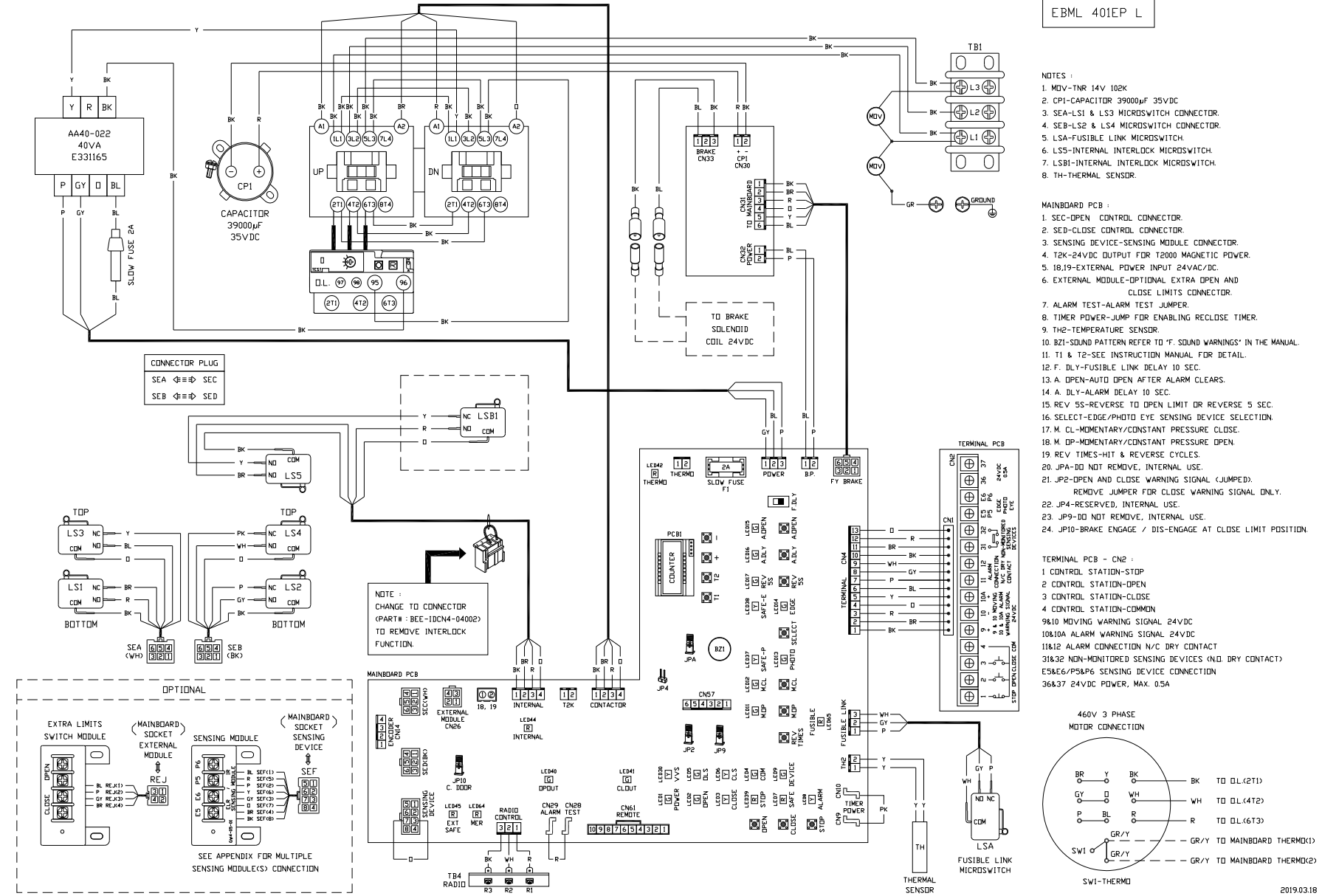

- NOTES :**
- MOV-TNR 14V 10K
 - CP1-CAPACITOR 39000µF 35VDC
 - SEA-LS1 & LS3 MICROSWITCH CONNECTOR.
 - SEB-LS2 & LS4 MICROSWITCH CONNECTOR.
 - LSA-FUSIBLE LINK MICROSWITCH.
 - LS5-INTERNAL INTERLOCK MICROSWITCH.
 - LSBI-INTERNAL INTERLOCK MICROSWITCH.
 - TH-THERMAL SENSOR.
- MAINBOARD PCB :**
- SEC-OPEN CONTROL CONNECTOR.
 - SEC-CLOSE CONTROL CONNECTOR.
 - SENSING DEVICE-SENSING MODULE CONNECTOR.
 - T2K-24VDC OUTPUT FOR T2000 MAGNETIC POWER.
 - 18,19-EXTERNAL POWER INPUT 24VAC/DC.
 - EXTERNAL MODULE-OPTIONAL EXTRA OPEN AND CLOSE LIMITS CONNECTOR.
 - ALARM TEST-ALARM TEST JUMPER.
 - TIMER POWER-JUMP FOR ENABLING RECLOSE TIMER.
 - TH2-TEMPERATURE SENSOR.
 - BZ1-SOUND PATTERN REFER TO 'F. SOUND WARNINGS' IN THE MANUAL.
 - T1 & T2-SEE INSTRUCTION MANUAL FOR DETAIL.
 - F. DLY-FUSIBLE LINK DELAY 10 SEC.
 - A. OPEN-AUTO OPEN AFTER ALARM CLEARS.
 - A. DLY-ALARM DELAY 10 SEC.
 - REVERSE 5S-REVERSE TO OPEN LIMIT OR REVERSE 5 SEC.
 - SELECT-EDGE/PHOTO EYE SENSING DEVICE SELECTION.
 - M. CL-MOMENTARY/CONSTANT PRESSURE CLOSE.
 - M. DP-MOMENTARY/CONSTANT PRESSURE OPEN.
 - RE. VY-TIMES-HIT & REVERSE CYCLES.
 - JP4-DO NOT REMOVE, INTERNAL USE.
 - JP2-OPEN AND CLOSE WARNING SIGNAL (JUMPED). REMOVE JUMPER FOR CLOSE WARNING SIGNAL ONLY.
 - JP4-RESERVED, INTERNAL USE.
 - JP9-DO NOT REMOVE, INTERNAL USE.
 - JP10-BRAKE ENGAGE / DIS-ENGAGE AT CLOSE LIMIT POSITION.

FSML 460V 3 PHASE 50/60HZ RH (EP BOARD)
(FOR FSML-34EP)

EBML 401EP R

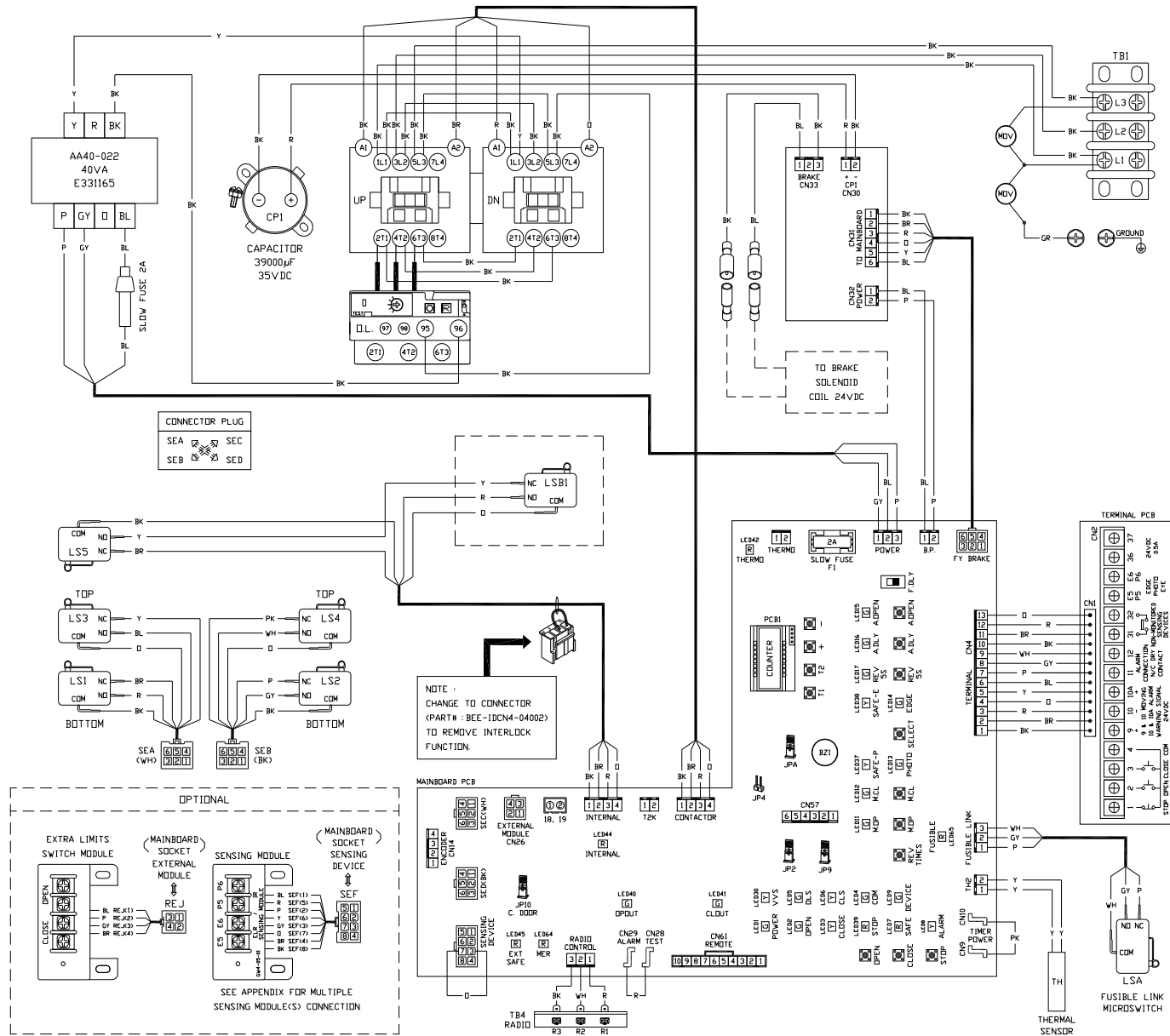

- NOTES :
1. MOV-TNR 14V 102K
 2. CPI-CAPACITOR 39000µF 35VDC
 3. SEA-LS1 & LS3 MICROSWITCH CONNECTOR
 4. SEB-LS2 & LS4 MICROSWITCH CONNECTOR
 5. LSA-FUSIBLE LINK MICROSWITCH
 6. LSS-INTERNAL INTERLOCK MICROSWITCH
 7. LSB1-INTERNAL INTERLOCK MICROSWITCH
 8. TH-THERMAL SENSOR

- MAINBOARD PCB :
1. SEC-OPEN CONTROL CONNECTOR
 2. SED-CLOSE CONTROL CONNECTOR
 3. SENSING DEVICE-SENSING MODULE CONNECTOR
 4. T2K-24VDC OUTPUT FOR T2000 MAGNETIC PULLER
 5. 18,19-EXTERNAL PDWER INPUT 24VAC/DC
 6. EXTERNAL MODULE-OPTIONAL EXTRA OPEN AND CLOSE LIMITS CONNECTOR
 7. ALARM TEST-ALARM TEST JUMPER
 8. TIMER POWER-JUMP FOR ENABLING RECLOSE TIMER
 9. TH2-TEMPERATURE SENSOR
 10. BZ1-SOUND PATTERN REFER TO 'F. SOUND WARNINGS' IN THE MANUAL
 11. T1 & T2-SEE INSTRUCTION MANUAL FOR DETAIL
 12. F. DLY-FUSIBLE LINK DELAY 10 SEC
 13. A. OPEN-AUTO OPEN AFTER ALARM CLEARS
 14. A. DLY-ALARM DELAY 10 SEC
 15. REV 5S-REVERSE TO OPEN LIMIT DR REVERSE 5 SEC
 16. SELECT-EDGE/PHOTO EYE SENSING DEVICE SELECTION
 17. M. CL-MOMENTARY/CONSTANT PRESSURE CLOSE
 18. M. DP-MOMENTARY/CONSTANT PRESSURE OPEN
 19. REV TIMES-HIT & REVERSE CYCLES
 20. JPA-DO NOT REMOVE, INTERNAL USE
 21. JP2-OPEN AND CLOSE WARNING SIGNAL (JUMPED). REMOVE JUMPER FOR CLOSE WARNING SIGNAL ONLY.
 22. JP4-RESERVED, INTERNAL USE
 23. JP9-DO NOT REMOVE, INTERNAL USE
 24. JP10-BRAKE ENGAGE / DIS-ENGAGE AT CLOSE LIMIT POSITION

- TERMINAL PCB - CN2 :
- 1 CONTROL STATION-STOP
 - 2 CONTROL STATION-OPEN
 - 3 CONTROL STATION-CLOSE
 - 4 CONTROL STATION-COMMON
- 9810 MOVING WARNING SIGNAL 24VDC
10&10A ALARM WARNING SIGNAL 24VDC
11&12 ALARM CONNECTION N/C DRY CONTACT
31&32 NON-MONITORED SENSING DEVICES (N.D. DRY CONTACT)
E5&E6/P5&P6 SENSING DEVICE CONNECTION
36&37 24VDC POWER, MAX. 0.5A

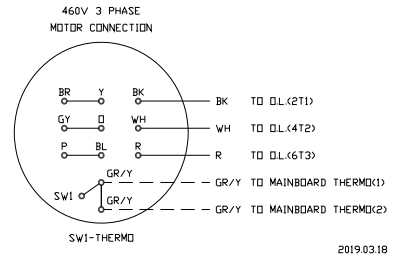

2019.03.18

FSML 575V 3 PHASE 60HZ LH (EP BOARD)
(FOR FSML-38EP)

E.BML 601EP L

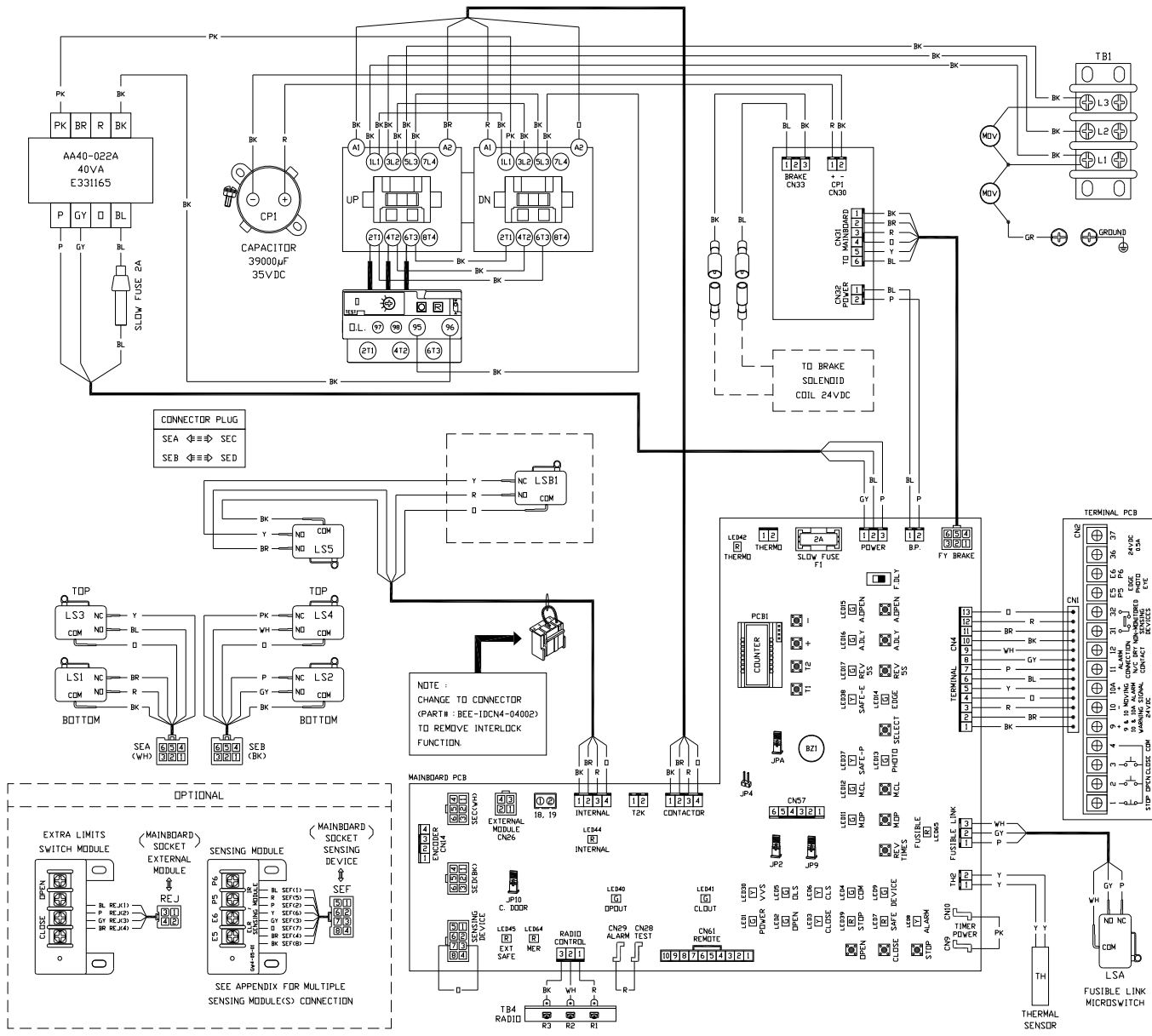

- NOTES :
- MOV-TNR 14V 122K
 - CP1-CAPACITOR 39000µF 35VDC
 - SEA-LS1 & LS3 MICROSWITCH CONNECTOR
 - SEB-LS2 & LS4 MICROSWITCH CONNECTOR
 - LSA-FUSIBLE LINK MICROSWITCH
 - LSS-INTERNAL INTERLOCK MICROSWITCH
 - LSB1-INTERNAL INTERLOCK MICROSWITCH
 - TH-THERMAL SENSOR

- MAINBOARD PCB :
- SEC-OPEN CONTROL CONNECTOR.
 - SEC-CLOSE CONTROL CONNECTOR.
 - SENSING DEVICE-SENSING MODULE CONNECTOR.
 - TK-24VDC OUTPUT FOR T2000 MAGNETIC POWER.
 - 18,19-EXTERNAL POWER INPUT 24VAC/DC
 - EXTERNAL MODULE-OPTIONAL EXTRA OPEN AND CLOSE LIMITS CONNECTOR.
 - ALARM TEST-ALARM TEST JUMPER.
 - TIMER POWER-JUMP FOR ENABLING RECLOSE TIMER.
 - TH2-TEMPERATURE SENSOR.
 - BZ1-SOUND PATTERN REFER TO "F. SOUND WARNINGS" IN THE MANUAL.
 - T1 & T2-SEE INSTRUCTION MANUAL FOR DETAIL.
 - F. DLY-FUSIBLE LINK DELAY 10 SEC.
 - A. DPEN-AUTO OPEN AFTER ALARM CLEARS.
 - A. DLY-ALARM DELAY 10 SEC.
 - REV SS-REVERSE TO OPEN LIMIT OR REVERSE 5 SEC.
 - SELECT-EDGE/PHOTO EYE SENSING DEVICE SELECTION.
 - M. CL-MOMENTARY/CONSTANT PRESSURE CLOSE.
 - M. DP-MOMENTARY/CONSTANT PRESSURE OPEN.
 - REV TIMES-HIT & REVERSE CYCLES.
 - JP4-DO NOT REMOVE, INTERNAL USE.
 - JP2-OPEN AND CLOSE WARNING SIGNAL (JUMPED). REMOVE JUMPER FOR CLOSE WARNING SIGNAL ONLY.
 - JP4-RESERVED, INTERNAL USE.
 - JP9-DO NOT REMOVE, INTERNAL USE.
 - JP10-BRAKE ENGAGE / DIS-ENGAGE AT CLOSE LIMIT POSITION.

- TERMINAL PCB - CN2 :
- CONTROL STATION-STOP
 - CONTROL STATION-OPEN
 - CONTROL STATION-CLOSE
 - CONTROL STATION-COMMON
 - 9&10 MOVING WARNING SIGNAL 24VDC
 - 10&10A ALARM WARNING SIGNAL 24VDC
 - 11&12 ALARM CONNECTION N/C DRY CONTACT
 - 31&32 NON-MONITORED SENSING DEVICES (N/D DRY CONTACT)
 - ES&6/P5&P6 SENSING DEVICE CONNECTION
 - 36&37 24VDC POWER, MAX. 0.5A

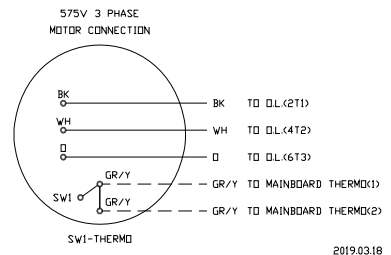

2019.03.18

FSML 575V 3 PHASE 60HZ RH (EP BOARD)
(FOR FSML-38EP)

EBML 601EP R

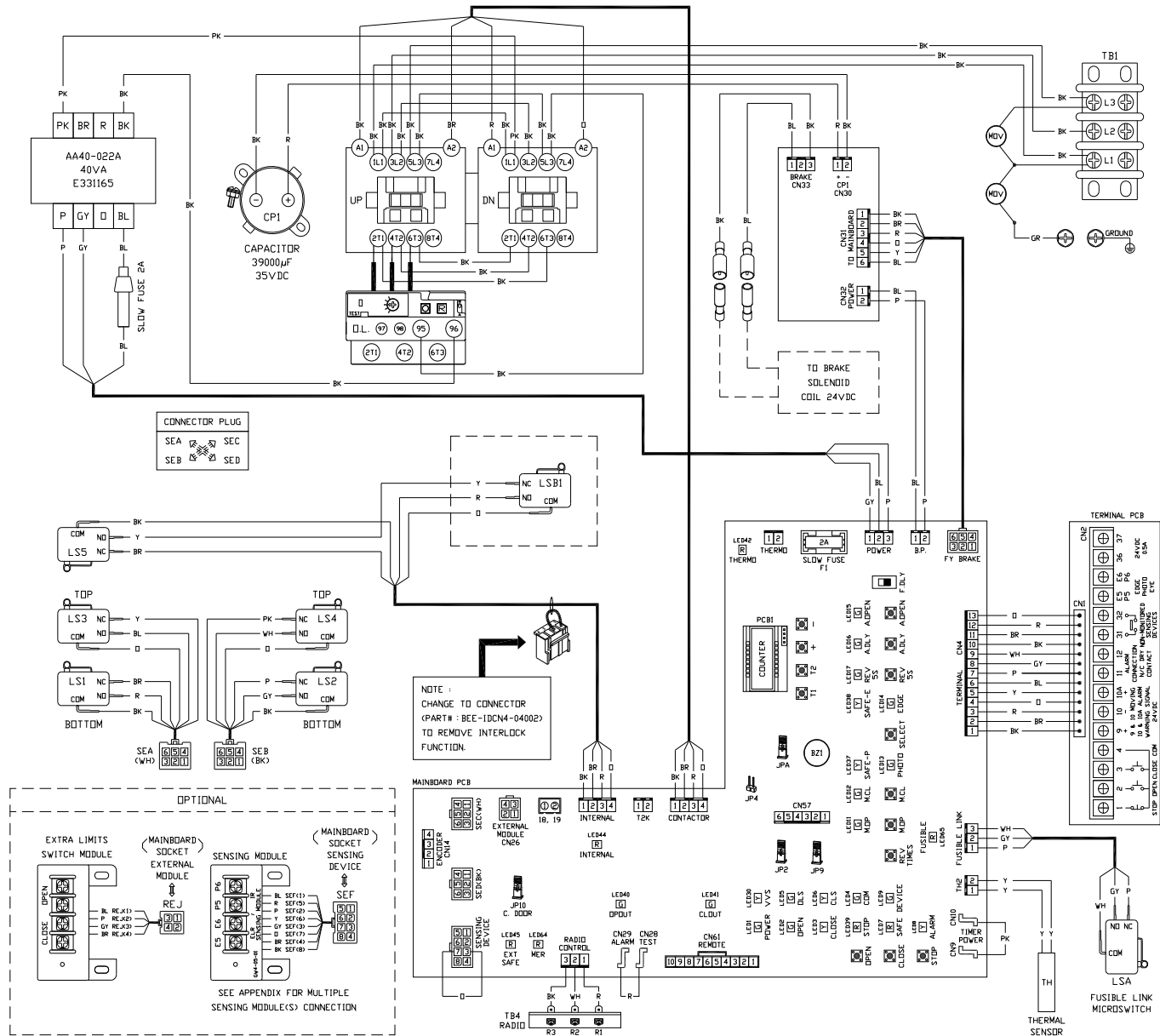

- NOTES :
- MOV-TNR 14V 122K
 - CP1-CAPACITOR 39000µF 35VDC
 - SEA-LS1 & LS3 MICROSWITCH CONNECTOR.
 - SEB-LS2 & LS4 MICROSWITCH CONNECTOR.
 - LSA-FUSIBLE LINK MICROSWITCH.
 - LS5-INTERNAL INTERLOCK MICROSWITCH
 - LSBI-INTERNAL INTERLOCK MICROSWITCH.
 - TH-THERMAL SENSOR.
- MAINBOARD PCB :
- SEC-OPEN CONTROL CONNECTOR.
 - SED-CLOSE CONTROL CONNECTOR.
 - SENSING DEVICE-SENSING MODULE CONNECTOR.
 - TPK-24VDC OUTPUT FOR T2000 MAGNETIC POWER.
 - 18,19-EXTERNAL POWER INPUT 24VAC/DC.
 - EXTERNAL MODULE-OPTIONAL EXTRA OPEN AND CLOSE LIMITS CONNECTOR.
 - ALARM TEST-ALARM TEST JUMPER.
 - TIMER POWER-JUMP FOR ENABLING RECLOSE TIMER.
 - TH2-TEMPERATURE SENSOR.
 - BZ1-SOUND PATTERN REFER TO 'SOUND WARNINGS' IN THE MANUAL.
 - T1 & T2-SEE INSTRUCTION MANUAL FOR DETAIL.
 - DLY-DLY-FUSIBLE LINK DELAY 10 SEC.
 - A-OPEN-AUTO OPEN AFTER ALARM CLEARS.
 - A DLY-ALARM DELAY 10 SEC.
 - REV 5S-REVERSE TO OPEN LIMIT OR REVERSE 5 SEC.
 - SELECT-EDGE/PHOTO EYE SENSING DEVICE SELECTION.
 - M-CL-MOMENTARY/CONSTANT PRESSURE CLOSE.
 - M-OP-MOMENTARY/CONSTANT PRESSURE OPEN.
 - REV TIMES-HIT & REVERSE CYCLES.
 - JPA-DO NOT REMOVE, INTERNAL USE.
 - JP2-OPEN AND CLOSE WARNING SIGNAL (JUMPED). REMOVE JUMPER FOR CLOSE WARNING SIGNAL ONLY.
 - JP4-RESERVED, INTERNAL USE.
 - JP9-DO NOT REMOVE, INTERNAL USE.
 - JP10-BRAKE ENGAGE / DIS-ENGAGE AT CLOSE LIMIT POSITION.
- TERMINAL PCB - CN2 :
- CONTROL STATION-STOP
 - CONTROL STATION-OPEN
 - CONTROL STATION-CLOSE
 - CONTROL STATION-COMMON
- 9810 MOVING WARNING SIGNAL 24VDC
10810A ALARM WARNING SIGNAL 24VDC
11812 ALARM CONNECTION N/C DRY CONTACT
31832 NON-MONITORED SENSING DEVICES (N.O. DRY CONTACT)
E58E6/P58P6 SENSING DEVICE CONNECTION
36&37 24VDC POWER, MAX. 0.5A

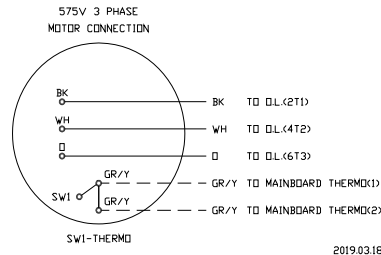

2019.03.18

IMPORTANT SAFETY INSTRUCTIONS

WARNING –To reduce the risk of death or serious injury:

1. READ AND FOLLOW ALL INSTRUCTIONS.
2. Never let children operate or play with door controls. Keep the remote control (when provided) away from children.
3. Personnel should keep away from a door in motion and keep the moving door in sight until it is completely closed or opened. NO ONE SHOULD CROSS THE PATH OF A MOVING DOOR.



Fire doors could close rapidly at any time and cause death or serious injury.

WARNING

Do NOT stand in the doorway.

4. Test sensing devices at least once a month. Also test sensing devices after making any adjustments to the close limit. Failure to adjust the operator properly may cause death or serious injury.
5. For operators having an auxiliary release, use caution when using the release if the door is open. Weak or broken springs may cause the door to fall rapidly, causing death or serious injury.
6. KEEP DOORS PROPERLY OPERATING AND BALANCED. See door manufacturer's Operation and Maintenance Instructions. An improperly operating or unbalanced door could cause death or serious injury. Have trained door systems technicians make all necessary adjustments and repairs.
7. **SAVE THESE INSTRUCTIONS.**

FUSIBLE LINK CONNECTIONS

- ❖ REMOVE COTTER PIN FROM RELEASE ASSEMBLY AFTER INSTALLATION IS COMPLETE.

Refer to the fire door installation instructions for connection of the release assembly or consult NFPA-80 and the authority having jurisdiction for fusible link location(s) and method.

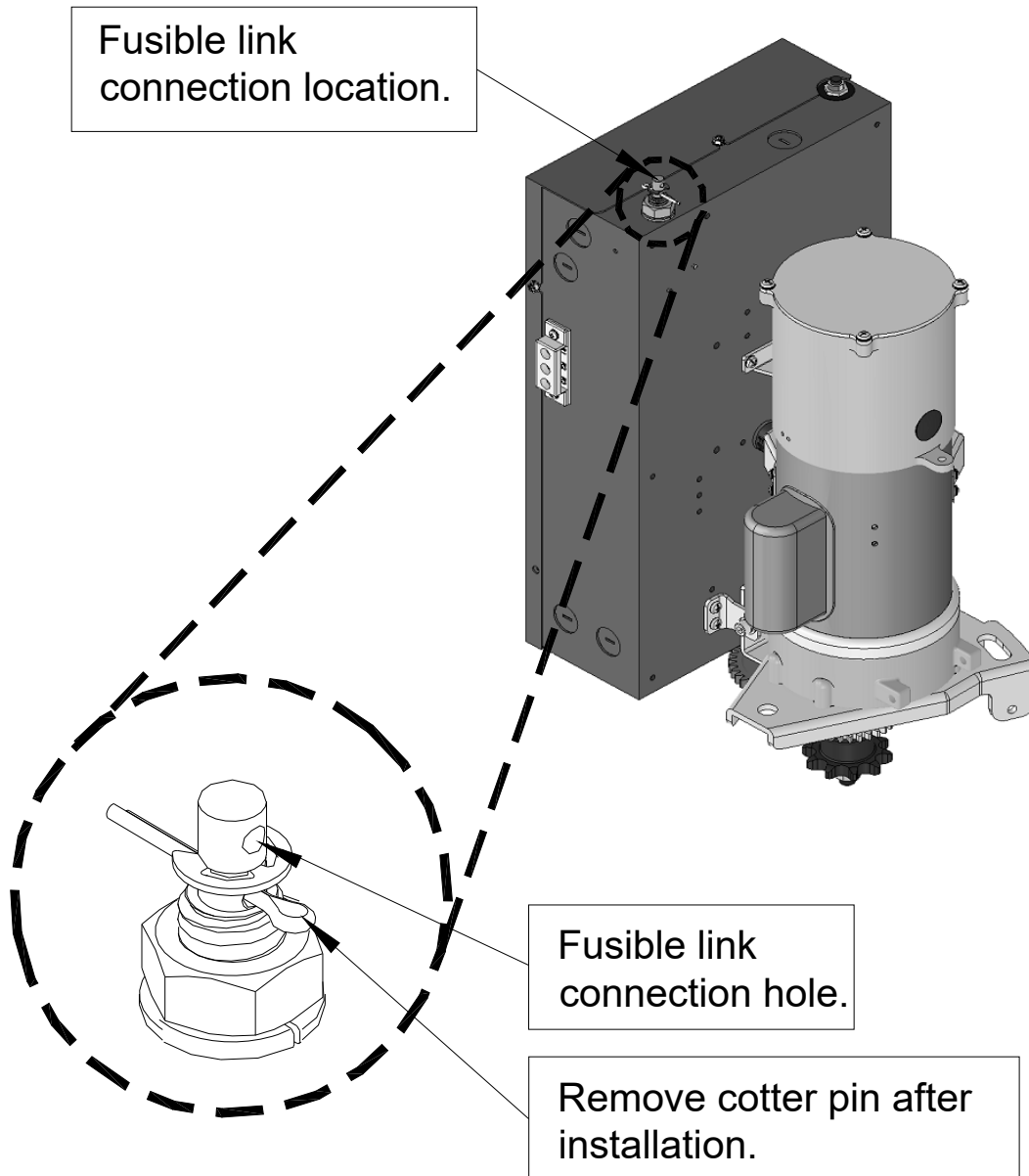

* Illustration only, not drawn to scale. See product for actual details.

OPERATING INSTRUCTIONS

1. If a 3-button control station is used to operate the door, push the “OPEN” button to open the door, push the “CLOSE” button to close the door, push the “STOP” button to stop movement of the door while opening or closing. With constant pressure close operation, removing pressure from the “CLOSE” button will also cause the door to stop.
2. If a key switch control station is used to operate the door, turn the key to the “OPEN” position to open the door, turn the key to the “CLOSE” position to close the door, push the “STOP” button to stop movement of the door while opening or closing. With constant pressure close operation, removing pressure from the “CLOSE” key position will cause the door to stop.
3. Door may also be operated by remote devices.

IMPORTANT NOTE: If one or more monitored sensing devices are installed, and determined by the operator to be not functioning properly, the door will either stay open, or re-open if closing. If this occurs, contact a trained door systems technician to make repairs. Until repairs can be made, the door can be opened and closed from the 3-button or key switch control station, but will require constant pressure on the close control to close the door.

MAINTENANCE INSTRUCTIONS

The brake is a self-adjusting brake. It is maintenance free. The brake assembly requires no additional adjustments for its lifetime.

If an entrapment protection device is used, i.e. sensing edge or photoelectric sensors, please consult the manufacturer for maintenance instruction.



WARNING

Disconnect power supply to the operator before servicing.

Check the following items at the intervals listed:

CHECK LIST	DESCRIPTION	EVERY 3 MONTHS	EVERY 6 MONTHS	EVERY 12 MONTHS
Drive Chain	Check for excessive slack. Check & adjust as required Lubricate.	●		
Sprockets	Check set screw tightness	●		
Fasteners	Check & tighten as required		●	
Bearings & Shafts	Check for wear & lubricate	●		
Drop-test	Inspect door, drop-test for proper operation and full closure per NFPA-80			●

- ❖ Do not lubricate motor. Motor bearings are rated for continuous operation.
- ❖ Inspect and service whenever a malfunction either door or operator is observed or suspected.
- ❖ Before servicing, always disconnect power supply to the operator.
- ❖ Replace fuses only with those of the same type and rating.
- ❖ All replacement parts must be obtained from the door manufacturer per NFPA-80.



WARNING

Do not place hands or tools in or near the operator when the power is connected or when testing control or sensing devices. Always disconnect power before servicing or adjusting the operator.

APPENDIX 1

Multiple Sensing Devices Connection Instruction

Warning: Power OFF When Connecting.

QST-FSM-EP-ADAPTER-1

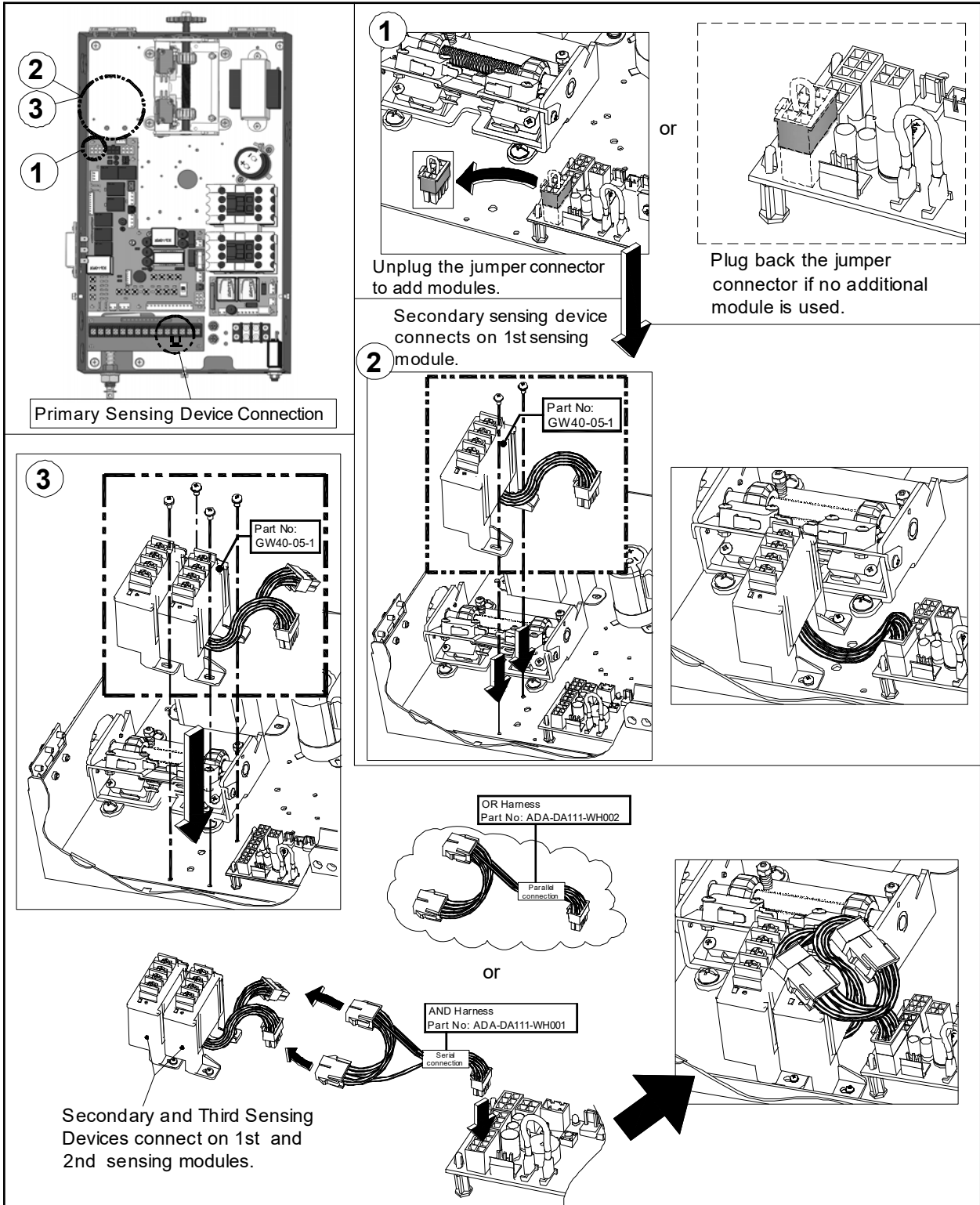

APPENDIX 2

Control Connections Diagrams

CCD-PCB-A01

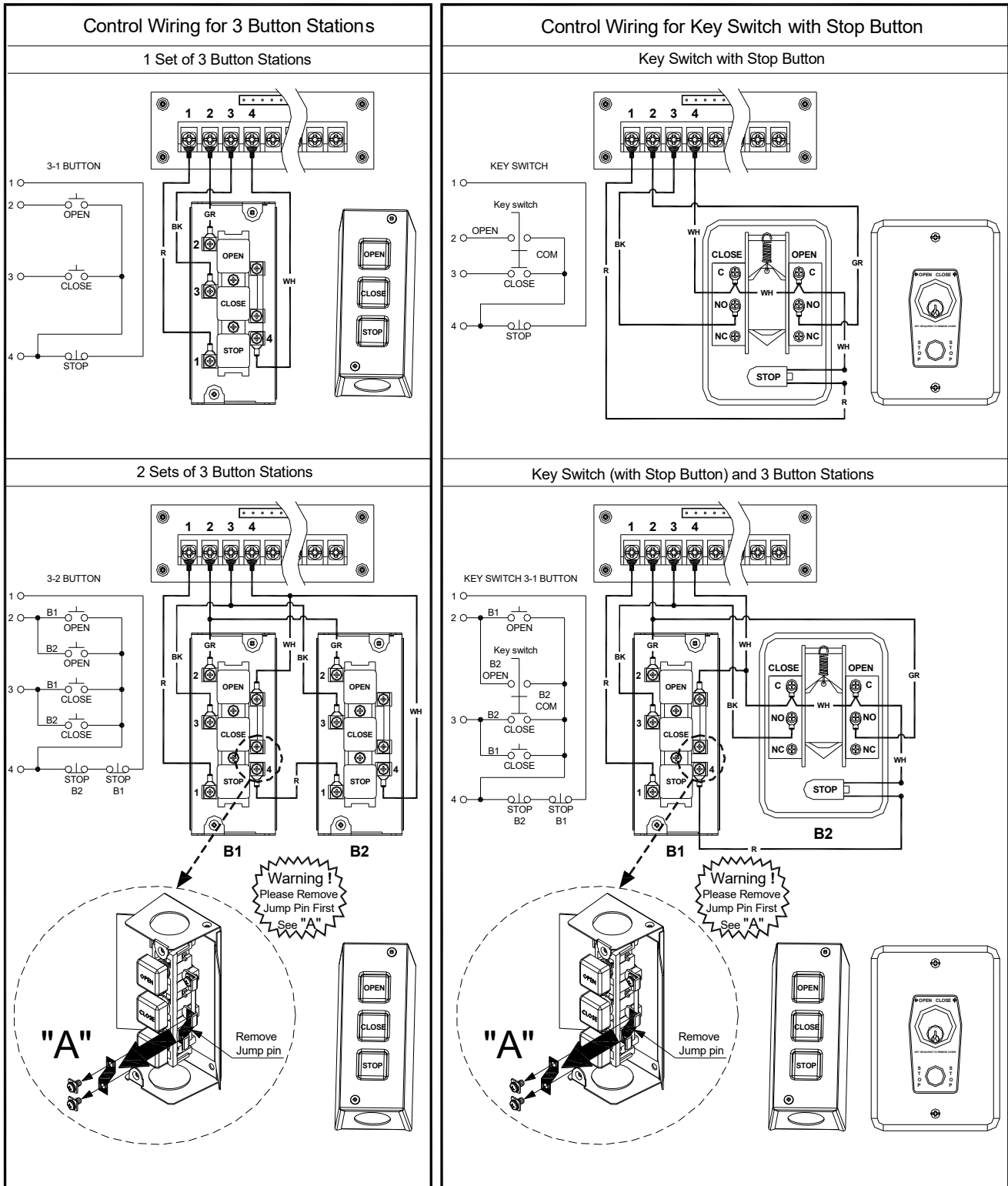

APPENDIX 3

Control Connections Diagrams

CCD-PCB-B02

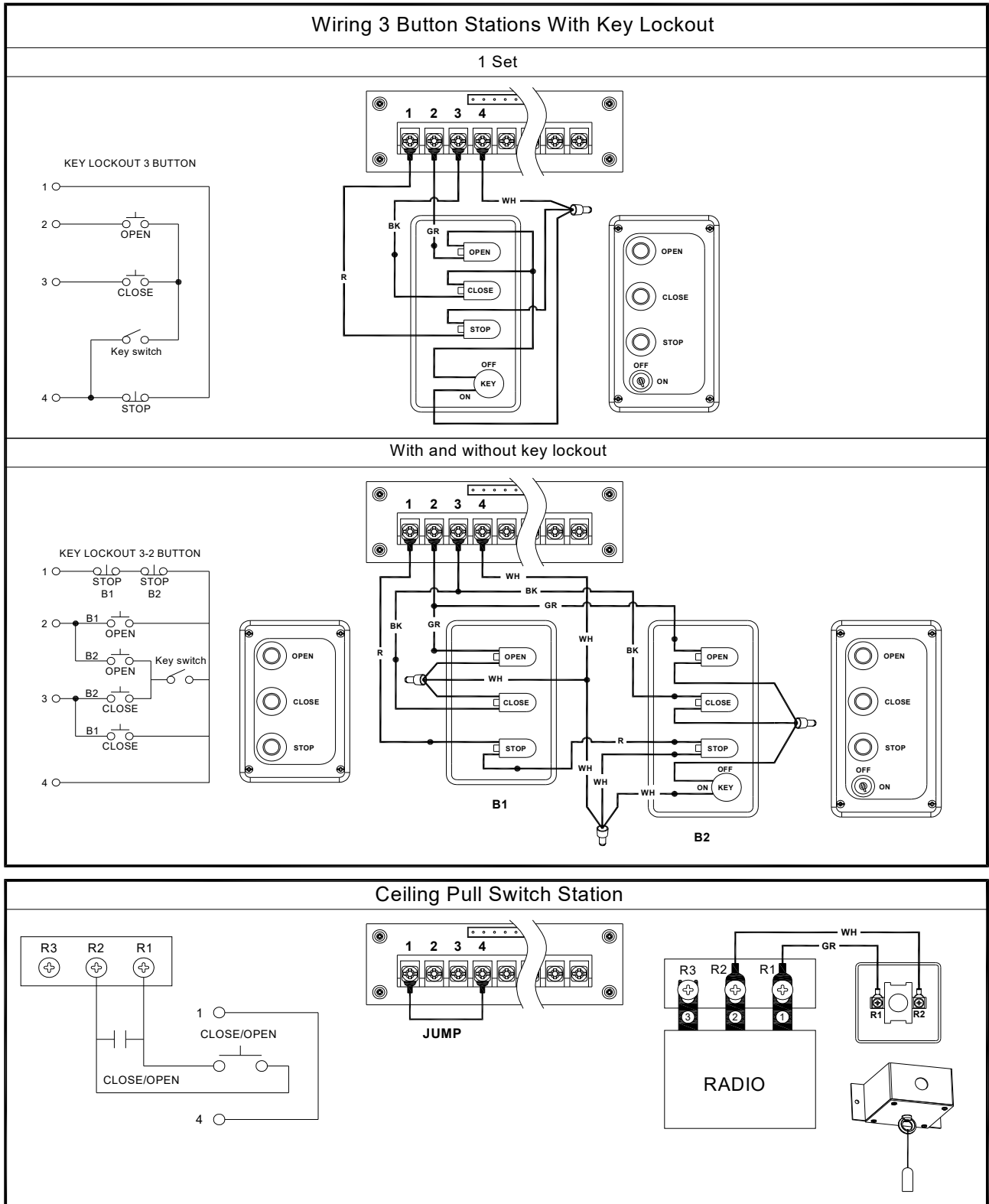

APPENDIX 4

Alarm Test Keyswitch Connection – FSML EP Board

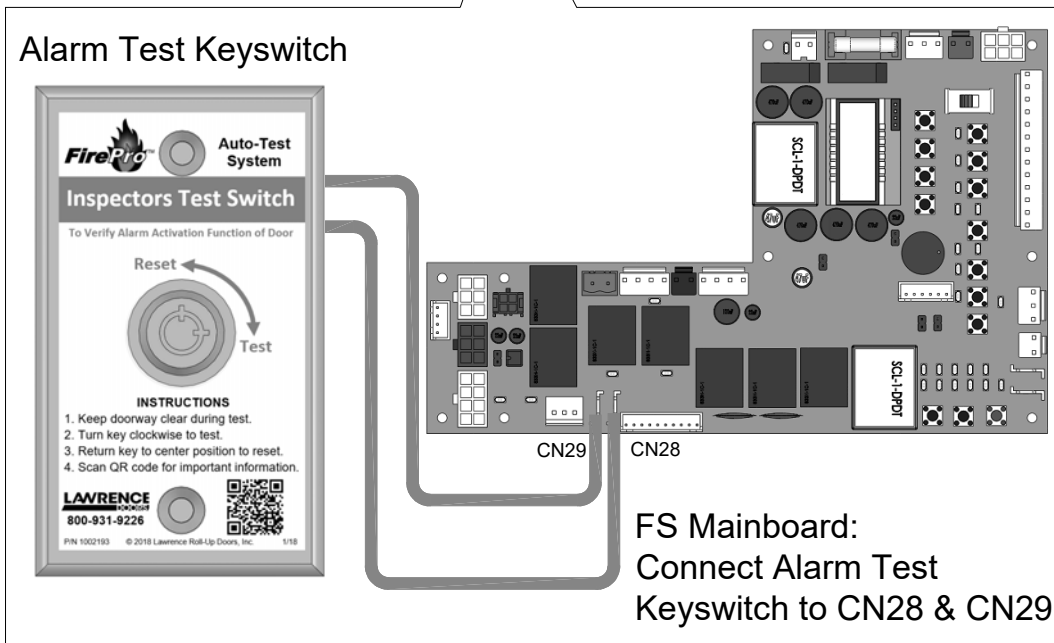
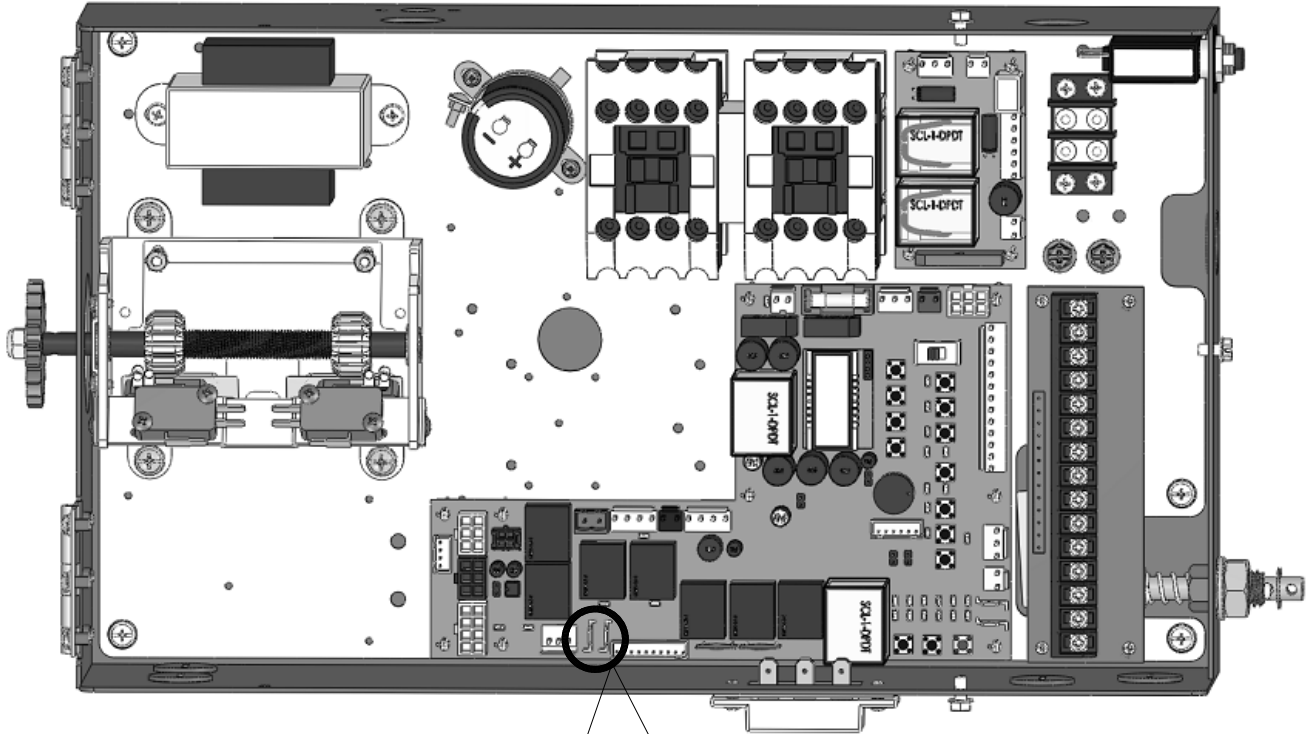

APPENDIX 5

EXTERNAL TIMER DEFEAT SWITCH CONNECTION-EP BOARD

ETDS-FSEP-004

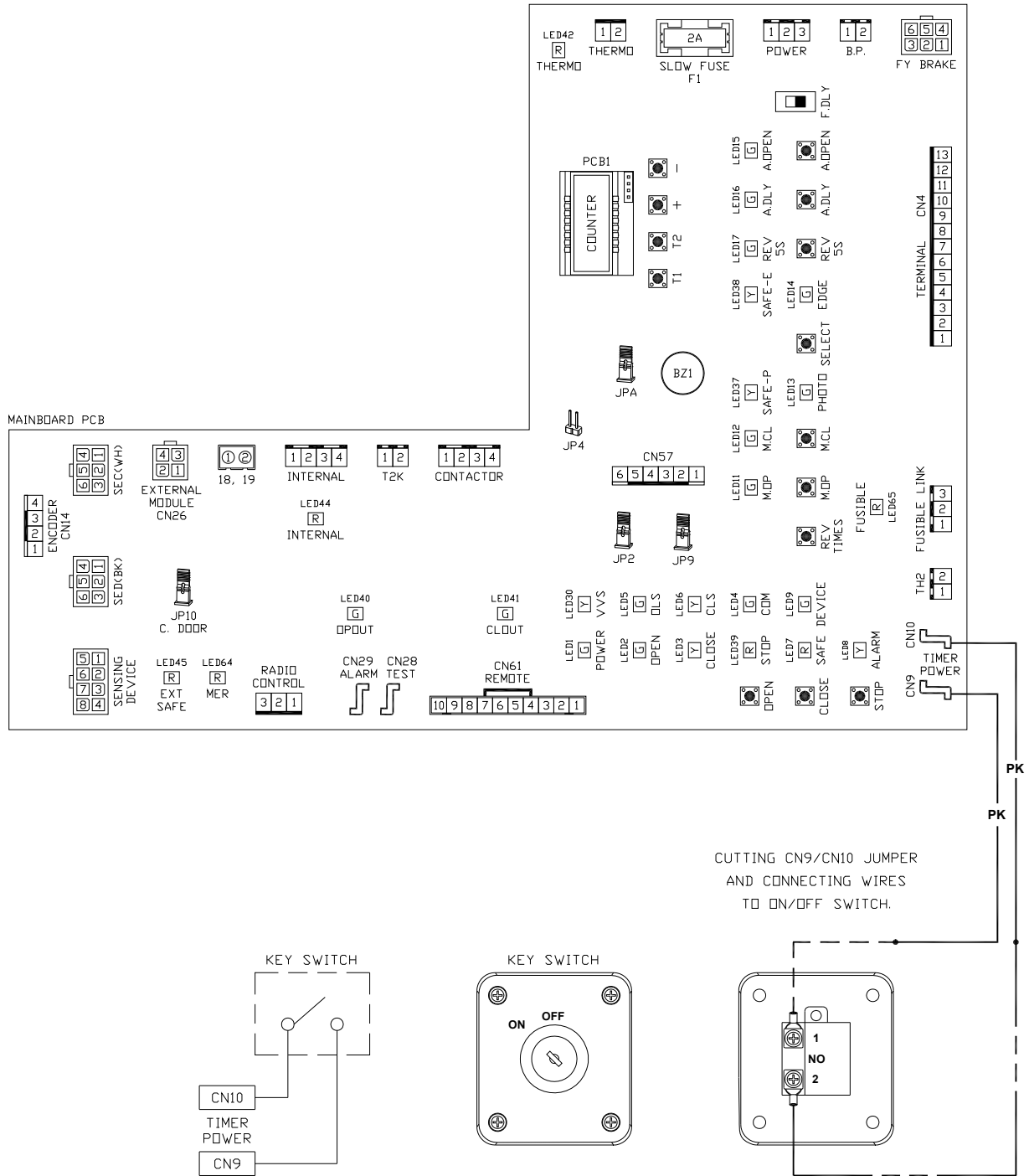

APPENDIX 6

Wiring Change Instruction from 230V to 208V 3 Phase Operator FS EP & FSML EP Series

FS-EP-3P-V03

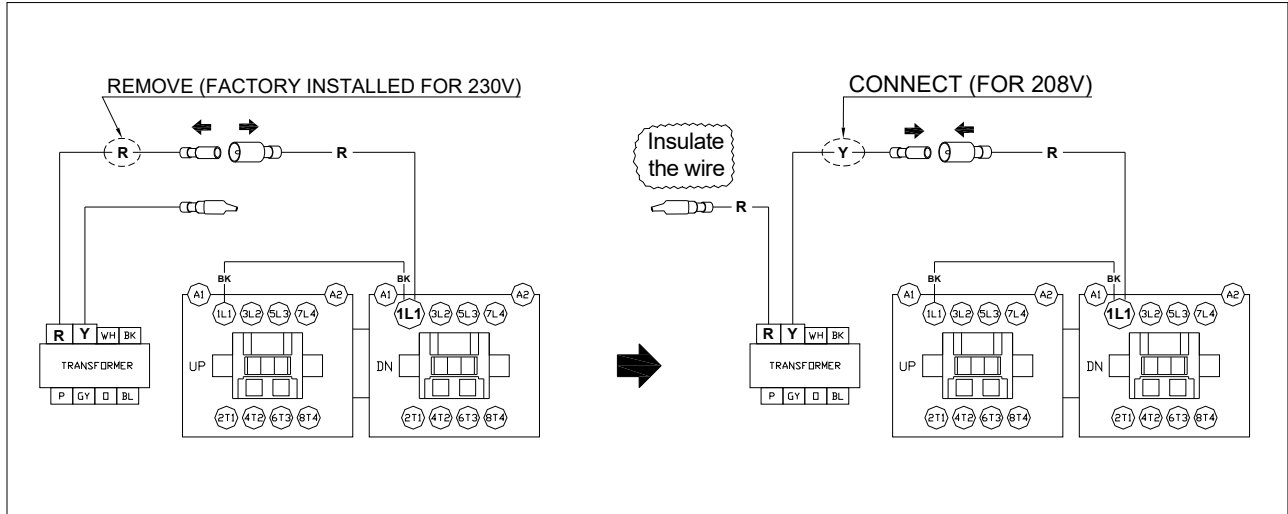

1. Unplug the red "230V" wire connector from the red "PWR" wire connector.
Remove the insulating cap from the yellow "208V" wire connector.

2. Put the insulating cap on the red "230V" wire connector.
Plug the yellow "208V" wire connector into the red "PWR" wire connector.

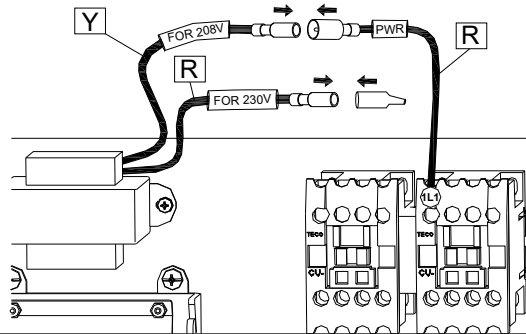
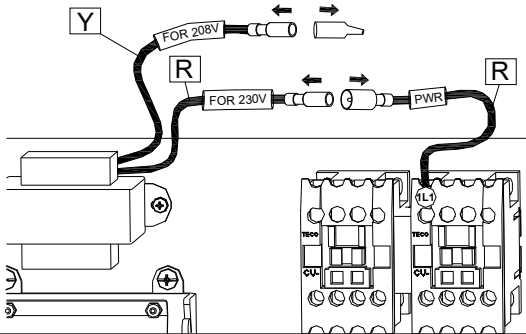

3. Completed.

