

CLEARANCES

Door Width "W"	TS	PS	CS	AS	MS
To 14'	5 1/2"	5 1/2"	7 3/4"	5 1/2"	5 1/2"
Over 14' to 24'	6 1/2"	N/A	8 1/4"	N/A	6 1/2"
Over 24' to 30'	7"	N/A	8 3/4"	N/A	7"

For Between Jamb Mount, add 3/4" to TS, PS, AS, MS
Consult factory for Tube Mount dimensions.

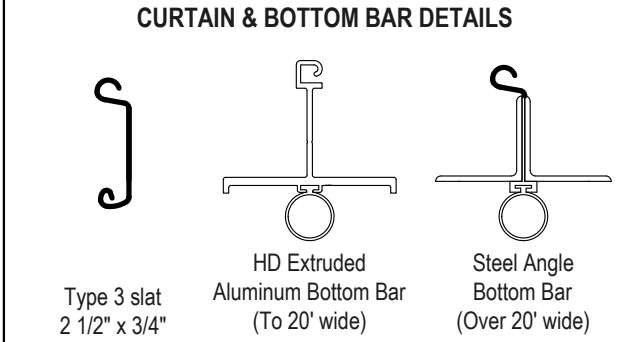
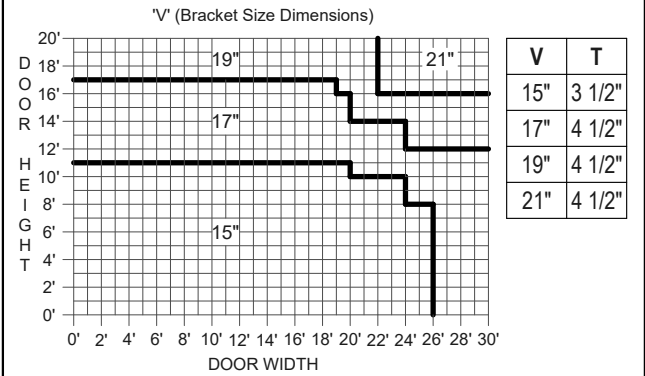

GENERAL NOTES:
Clearances are based upon standard door construction. Reduced clearances may be available. Some options may require additional clearance. Drive side shaft may need to be field cut to fit in clearances shown. Shop drawings for specific applications are available. Consult factory for any information not shown.