

INSTALLATION INSTRUCTIONS

AND

OPERATION MANUAL

FHN79 Series

NEMA 7/9 HAZARDOUS AREA

Commercial and Industrial Fire Door Operator

UL325 Compliant

Restricted Duty Operators

IMPORTANT INSTALLATION INSTRUCTIONS

WARNING –To reduce the risk of death or serious injury to persons:

1. READ AND FOLLOW ALL INSTALLATION INSTRUCTIONS.

WARNING! – Components under **extreme spring tension** can cause death or serious injury.

CAUTION – To reduce the risk of ignition of hazardous atmospheres, disconnect the equipment from the supply circuit before opening. Keep assembly tightly closed when in operation.

WARNING – To reduce the risk of ignition of hazardous atmospheres, conduit seals must be installed within 18 inches of this enclosure.

WARNING – Substitution of components may impair intrinsic safety.

2. Install only on a properly operating and balanced door. A door that is operating improperly could cause death or serious injury. Have trained door systems technicians make all necessary adjustments and repairs to the door before installing the operator.

Note: Fire door spring tension must be adjusted per the manufacturer's installation instructions to allow for automatic closing during fusible link/alarm activation and drop test. If an operator is connected to an alarm release, the door must also close in a power failure unless closing functions are supported by an approved battery back-up system.)

3. Remove any pull ropes that may be installed on the door.

4. Remove or make all door locks inoperative, or secure locks in the unlocked position to prevent operation with the locks engaged.

5. Install the door operator at least 8 feet or more above the floor if the operator has exposed moving parts. If the operator must be mounted less 8 ft (2.44 m) above the floor, then exposed moving parts must be protected by covers or guarding. Contact the manufacturer.

6. Install the fusible link cable from the release module on top of the operator per the requirements of NFPA-80.

7. Do not connect the door operator to the source of power until instructed to do so.

8. Locate the control station (open-close-stop push button, key station, or the like): (a) within sight of the door, and (b) at a minimum height of 5 feet above floors, landings, steps, or any other adjacent walking surface and (c) away from all moving parts of the door.

9. Install the Entrapment Warning Placard next to the control station in a prominent location.

10. Make sure the available power supply to be connected to the operator is of the same voltage, frequency, phase and wattage as indicated on the nameplate of the operator.
11. Read and understand the wiring diagram of the operator and the control station and any other equipment to be connected to the operator.
12. Always disconnect power whenever installing or servicing the door operator or door.
13. All wiring must be permanent and comply with National Electrical Code (NEC) and local code requirements.
14. Any change in mounting position may result in a change of operator rotation and consequently in a change of control functions. Consult factory for any changes.
15. If the operator is provided with an auxiliary chain operator, the hand chain must be kept inside the chain bag when operating electrically.
16. For products having a manual release, instruct the end user on the operation of the manual release.
17. The control box cover joints must be cleaned before replacing cover. Disconnect the equipment from the supply circuit before opening. Before opening or unfastening the screws, use a dry clean cloth to wipe off the dust to clean the cover joints. Alternatively, the cover joints can be blown clean with compressed air.

SPECIFICATIONS

CLASSIFICATION	
[Ex ia] Class I, Division 1, Group C & D; [Ex ia] Class II, Division 1, Group E, F & G; T3C	
MOTOR	
Type:	Restricted cycle duty (30 cycles per hour)
Horsepower:	1/2 hp, 3/4 hp, 1 hp, 1½ hp, 2 hp
Speed:	1700 RPM
Voltage:	115, 230 – 1 phase 208/230, 460, 575 – 3 phase 230 volt 3 phase motor is suitable for use with 208 volts (see <i>Wiring Diagrams and Appendix 4 for wiring change instructions</i>)
Current:	See motor nameplate
ELECTRICAL	
Transformer:	24VAC
Wiring Type:	Momentary pressure open, stop, constant pressure close (provided standard), with provision for momentary pressure close*
Limit Adjustment:	Linear driven, fully adjustable screw type cams.
MECHANICAL	
Drive Reduction:	57:1 (1/2, 3/4, 1 & 1½ hp), 82:1 (2 hp)
Output Shaft Speed:	30 RPM (1/2, 3/4, 1 & 1½ hp), 21 RPM (2 hp)
Door Speed:	6 - 8" per sec. average (typical)
Brake:	Solenoid actuated brake
Auxiliary Chain Hoist:	Standard
ENTRAPMENT PROTECTION	
Sensing Edge*:	(Optional) Sensing device, which has compatibility to the intrinsic safe circuit specifications as shown in the paragraph F, attached to the bottom edge of the door.
Non-Contact Device*:	(Optional) Explosion proof photo eye device with proper explosion proof type conduit and fittings connection.
<p>* Per the requirements of UL Standard 325, the door operator is setup for constant pressure to close the door. As an alternative, the door may be provided with at least one <u>monitored</u> sensing device that will reverse the door upon contact with, or upon detecting an obstruction, during closing.</p>	

Notes:

1. A non-contact sensing device (photo eye) can only be used on doors up to 35 ft. wide (or maximum rated range of device if less than 35 ft.). Use a sensing edge to provide entrapment protection on doors over 35 ft. wide.
2. A sensing edge can be used on all doors without size restriction.

TYPES AND SIZES OF DOORS

Consult factory for details.

INSTALLATION INSTRUCTIONS

INSTALLATION POSITIONS (for 1/2hp, 3/4hp, 1hp and 1½hp)

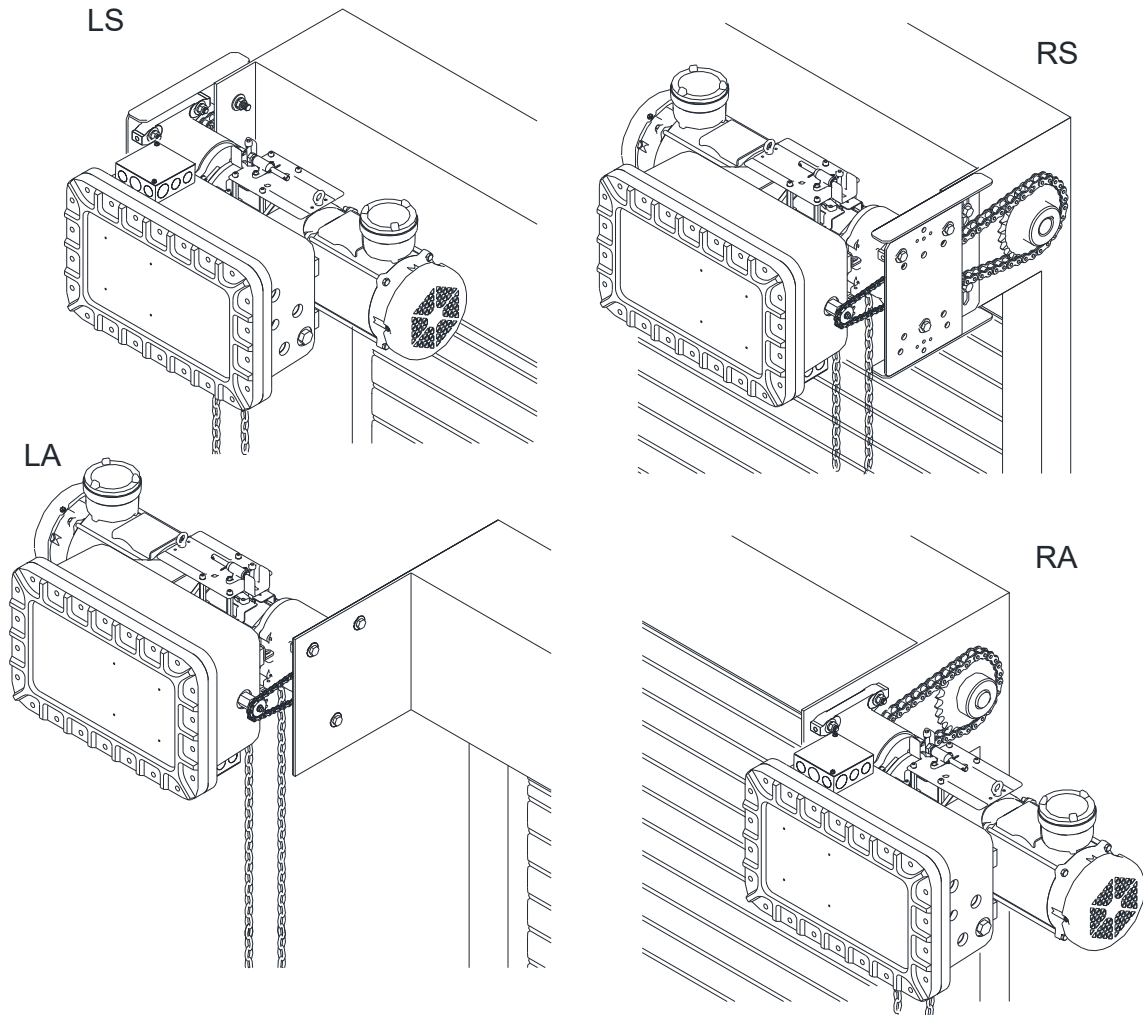

Installation positions for larger horsepower units are similar to as shown above.

Consult factory for changes in installation positions.

NOTE: Any change in mounting position may result in a change of operator rotation and consequently in a change of control functions. Consult factory for any changes. (LS and RA mounting positions are LH operators, RS and LA positions are RH operators)

Operators mounted in alternate positions (LA, RA) require a straight mounting plate in lieu of the standard bent plate.

OPERATOR MOUNTING

1. Before the operator is installed, verify that the door is properly operating and balanced.
2. Make sure the layout of the mounting holes on the bracket is correct.
3. Bolt the operator mounting plate to the door bracket plate.
4. Mount the operator base to the mounting plate.

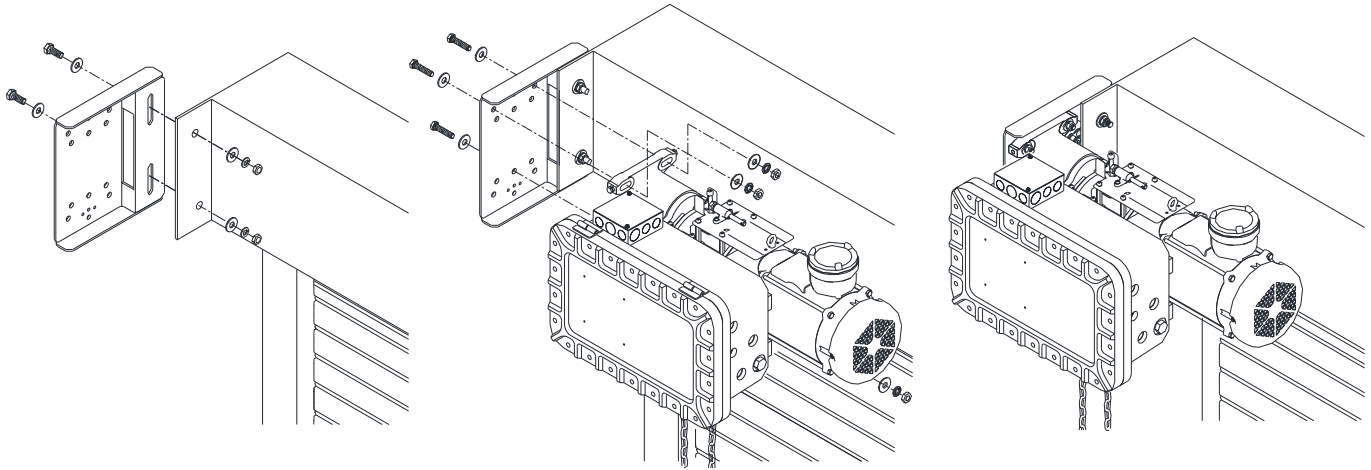

(Figure for 1/2 hp, 3/4 hp, 1hp and 1½hp)

Mounting for larger horsepower units is similar to as shown above.

5. When the operator assembly is attached to the door bracket, be sure the door driven sprocket is properly aligned with the operator drive sprocket before securing the driven sprocket to the shaft.
6. The bracket must provide adequate support for the operator. Prevent play between the operator and the door shaft. The operator must be securely attached with the drive shaft parallel to the door shaft. It may be necessary to field brace the operator/bracket.

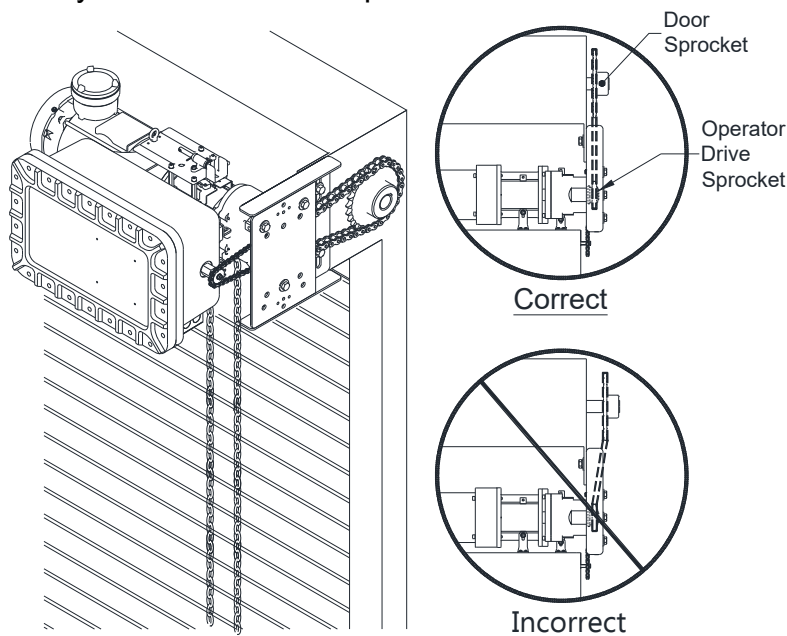

DRIVE CHAIN ADJUSTMENT

NOTE: Use correct type, size and proper length of roller chain.

1. Adjust the drive chain by tilting or move the operator so that there is about 1/4" of slack when the chain is depressed.

Note: The set screws on the operator base may be used to make the adjustment. (See figure - T1, T2 location).

2. Once the drive chain has been tightened and the base leg screws have been set, then tighten the operator set screws.

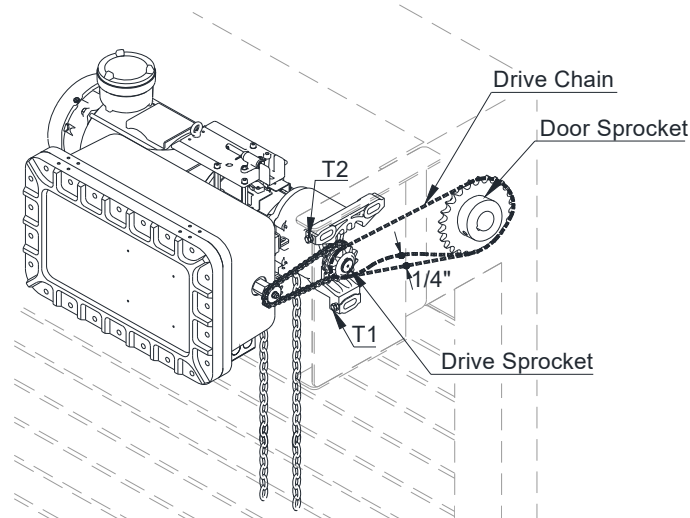

HAND CHAIN ADJUSTMENT

If the hand chain is too long, cut and reconnect the chain with the different color connecting link provided. Completely close the connecting link so it is properly aligned.

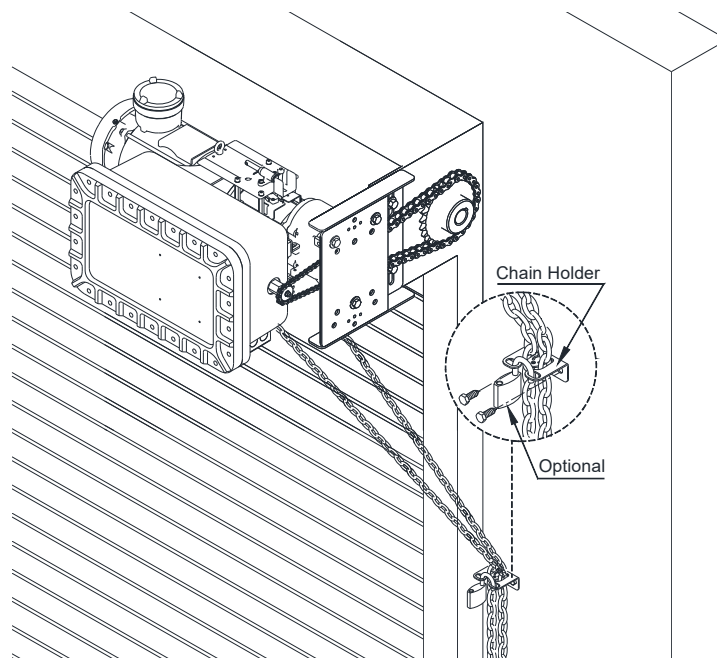

BRAKE RELEASE LEVER

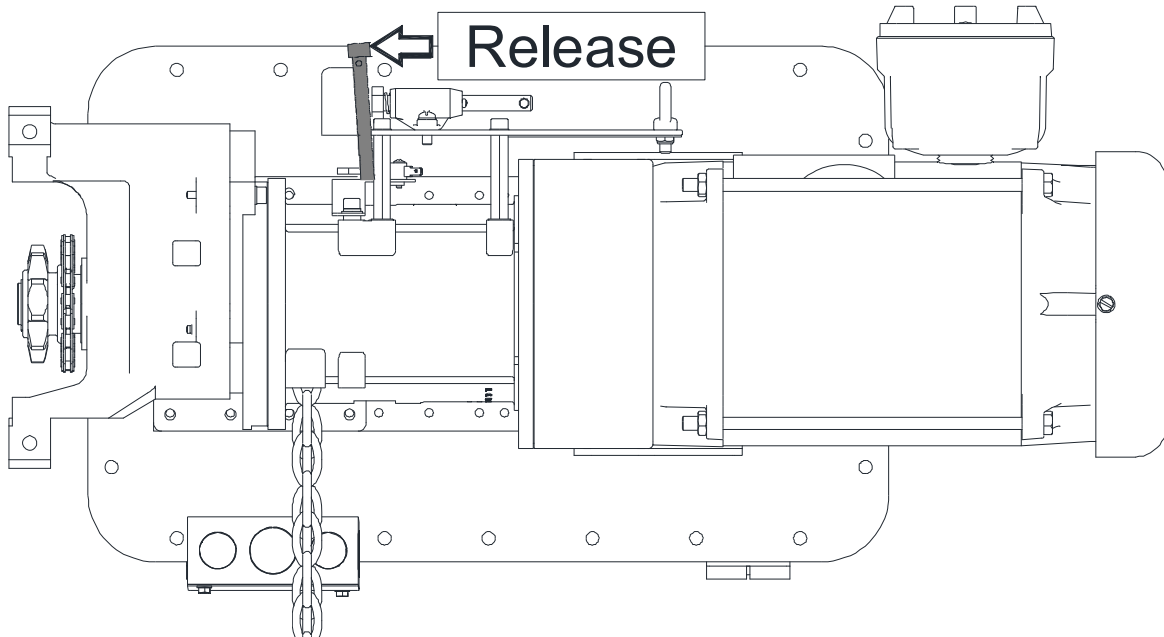

WARNING

Releasing the door operator brake, or loosening or removing any part of the door operator drive system, can cause the door to close and cause death or serious injury. **Do NOT release the brake, or loosen or remove any part of the door operator drive system**, unless the door is closed, or the curtain is secured in the open position to prevent uncoiling.

1. Pressing the brake release lever will release the motor brake and can cause the door to move uncontrolled.
2. Limit switch LSA1 is activated when the brake release lever is pressed – see wiring diagrams for details.
3. Open-close-stop controls do not function while the brake release lever is pressed.
4. Fire doors using this operator have counterbalance springs that are adjusted during installation to allow the door to close automatically upon activation of the door operator release mechanism (brake release) without requiring a loss of spring tension.

TYPICAL INSTALLATION

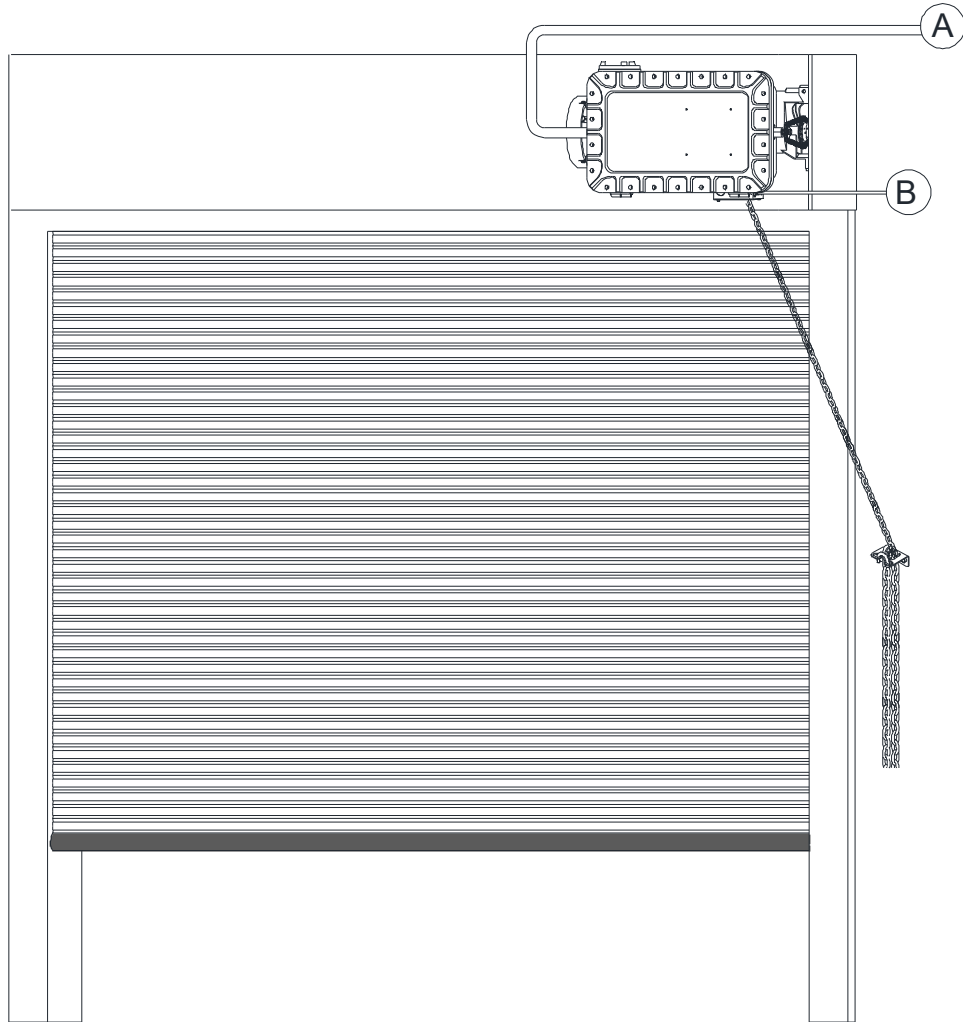

Illustration only, consult factory for details.

A = Input Power Connection (explosion proof conduit or fittings are required)

Using the 3/4"-14 NPT, 5 threads engaged, pitch of thread 1.814 mm conduit and fittings.

Conduit seals must be installed within 18 inches of this enclosure.

B = Intrinsically Safety Connection (explosion proof conduit and fittings are not required)

Refer to control drawing no. 3-V-R-017 as shown in paragraph F.

Note: All conduits and fittings except at the Intrinsically Safe Connection shall be UL Listed (EBNV/7) and follow the specifications of the explosion proof ratings for using in Class I, Division 1, Groups C and D; Class II, Division 1, Group E, F and G Hazardous Location.



WARNING

End User/ Installer MUST follow applicable NEC requirements along with Local requirements for Hazardous Wiring.

LIMIT SWITCH ADJUSTMENT

Make sure the limit cams are positioned between the limit switch actuators before proceeding with adjustments.

1. Open the control panel cover.
2. Open or close the door part way to determine the direction of travel of the limit switch cams.
3. Open or close the door to the desired position.



WARNING

Disconnect power before adjusting limit switch cams.

4. While pressing the spring-loaded lever (G), which holds the limit switch cams in place, adjust the limit switch cam (E or F) until the micro switch (C or D) clicking sound is heard.
5. If the limit switch cam cannot be rotated to its desired position, release the plate and move the door away from the desired position, then adjust the limit switch cam to its desired position. It may be necessary to repeat this step until the exact position has been reached.
6. Repeat step 3 and 4 for the opposite direction. Adjust close limit cams so that actuator is engaged as door fully closes to the floor.
7. "B" is usually the sensing edge cut-off switch and can be adjusted to accommodate sensing edge cut-off position. It is recommended that the switch position be adjusted as low as possible without interfering with close limit switch function.

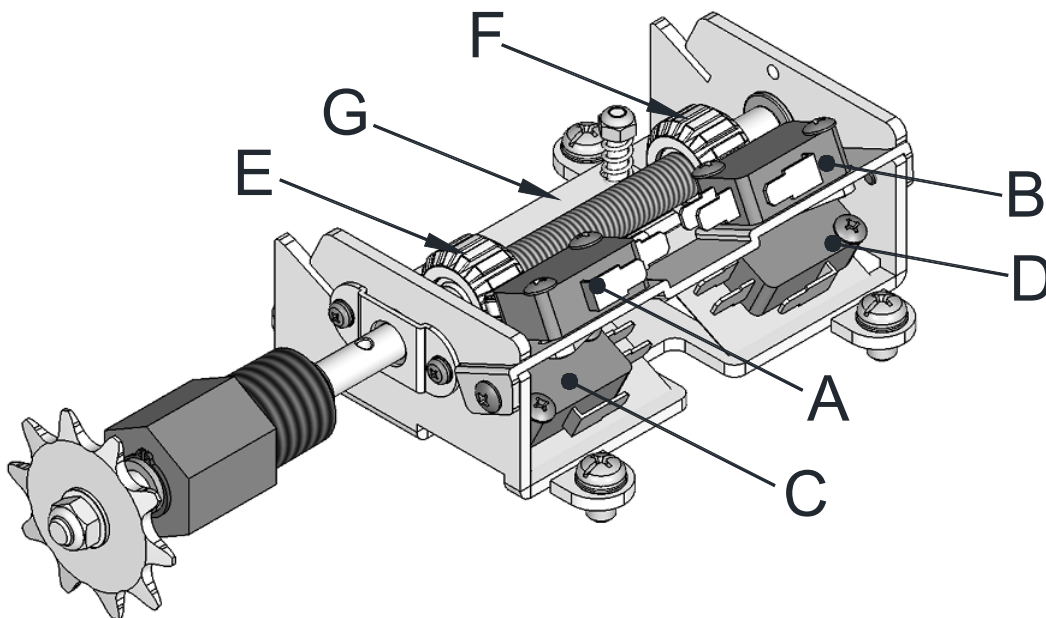

NOTE: "C" is usually the open limit switch and "D" is usually the close limit switch.

WIRING INSTRUCTIONS



Disconnect power at the fuse box before proceeding with any wiring.

WARNING

1. Do not install any wiring or attempt to run this operator without checking the wiring diagram located on the inside of the control box cover.
2. Do not turn on power until you have finished making all power and control wiring connections.
3. Do not run power and control wiring in the same conduit.
4. Any wire connected to the control panel must be protected by conduit or other means to ensure the safety and permanency of the wiring.
5. Use copper wire inside the control panel.
6. A separate fuse line of adequate capacity is needed for the operator.
7. The operator must be properly grounded. Green colored, hexagonal-head screw, suitable for No. 14 AWG wiring. Secured in base of control box as shown in the paragraph A. Surface of control box under screw head is free of paint or provided with star washer to cut paint.
8. The control box cover joints must be cleaned before replacing cover. Disconnect the equipment from the supply circuit before opening. Before opening or unfastening the screws, use dry clean cloth to wipe out the dust to cleaning the cover joints. Alternatively, the cover joints can be blown clean with compressed air.
9. For an operator, system, or external device requiring field installed wiring between a Class 2 output of an operator and an external device, the type of wiring shall be R/C (AVLV2/8), AWM, min. 22 AWG, rated 60°C, with VW-1/FT2.



WARNING

Failure to properly ground the operator could result in electric shock and death or serious injury.



WARNING

Remove or make all door locks inoperative, or secure locks in the unlocked position. Failure to disable the locks could result in damage to the door or operator.

CONTROL WIRING



WARNING

If the door is not visible from the control station, or if any device other than a control station requiring constant pressure to close the door is used, a monitored sensing device must be installed on the door. Failure to do so could result in serious injury or death to person(s) trapped beneath the door.



WARNING

Disconnect power at the fuse box before proceeding with any wiring.

1. Locate the control station at a minimum height of 5 feet above the floor, and where the user can clearly see the operation of the door. Mount the enclosed placard adjacent to or near the door.



WARNING

Controls shall be located far enough away from the door, or positioned such that the user is prevented from coming in contact with the door, while operating the controls.

2. Do not run control wiring in the same conduit as power wiring.
3. Any wire connected to the control panel must be protected by conduit or other means to ensure the safety and permanency of the wiring.



WARNING

Changing from left hand to right hand or vice versa could result in change of control wiring. Consult factory for details.

4. After installation, be sure that the operator, controls, and sensing edge or other entrapment protection devices have been tested and function properly.

A. Control Function:

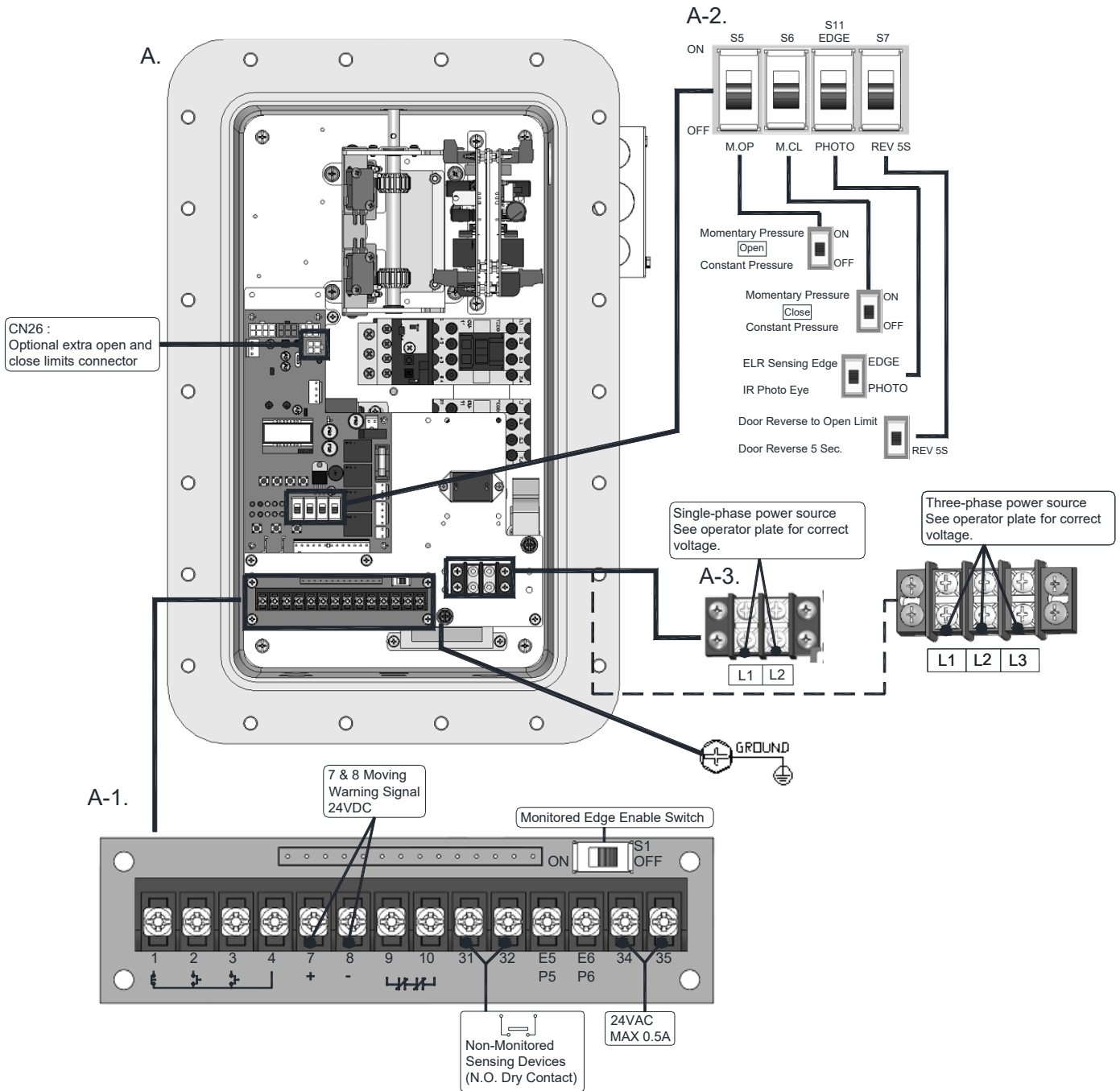

- ❖ A one-second delay on reverse is standard.
- ❖ When the door is closing, pushing the “Open” or “Stop” button will stop the door from moving.
- ❖ All control functions are disabled during automatic closing.

B. Auxiliary Function:

B.

B-1.

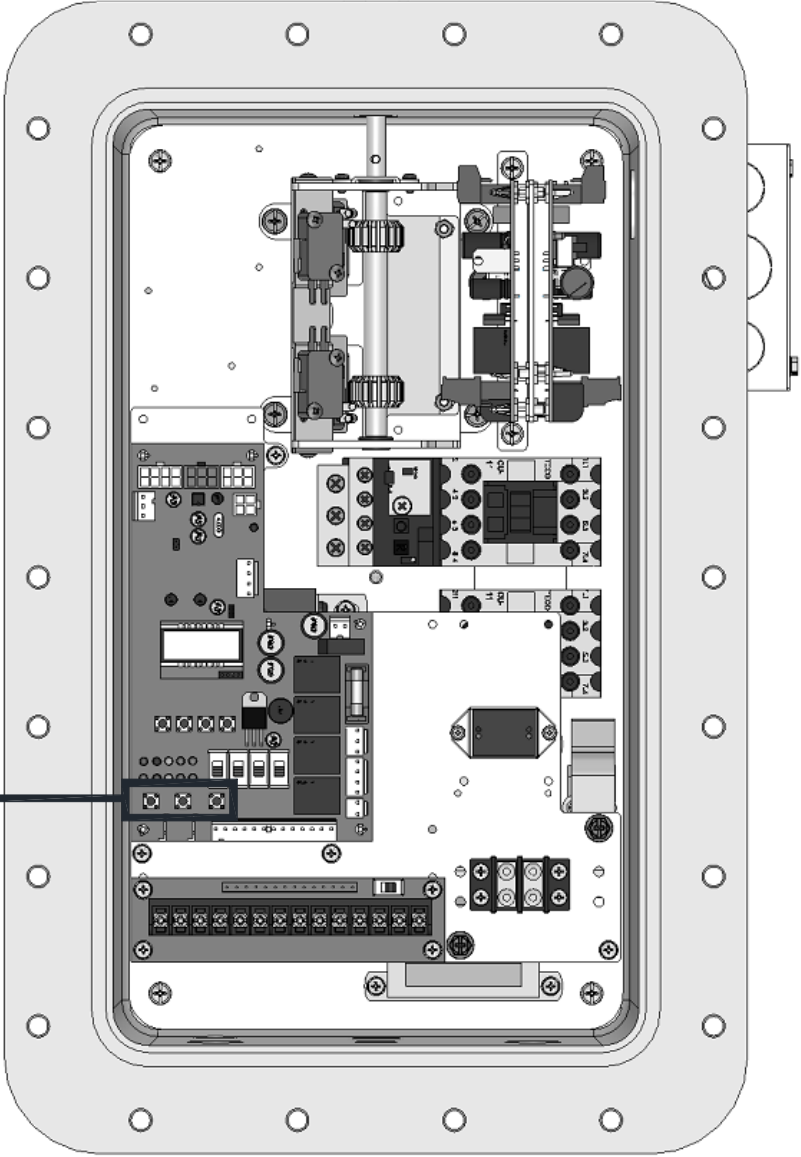
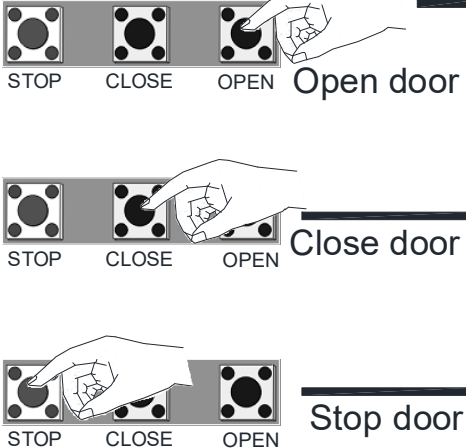

C. Timer Instruction:

C.

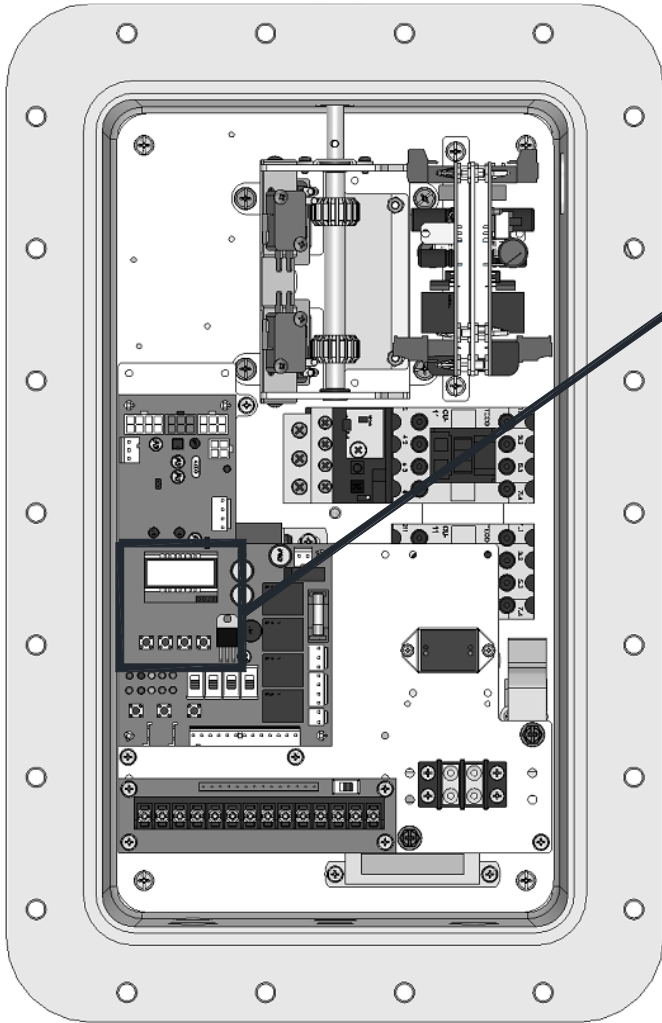

C-1.

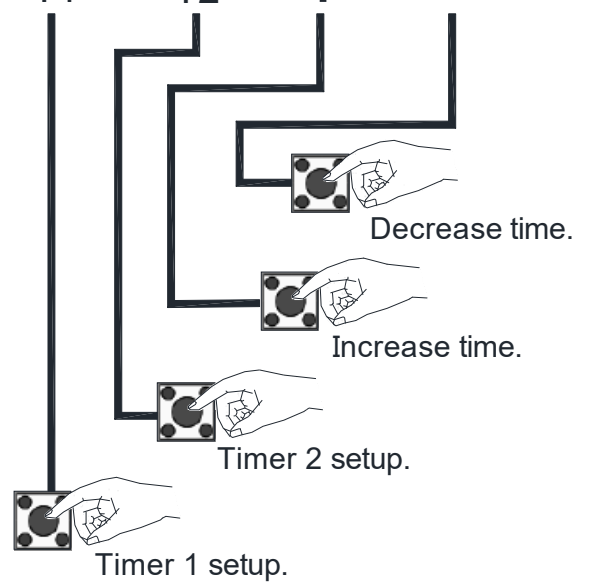
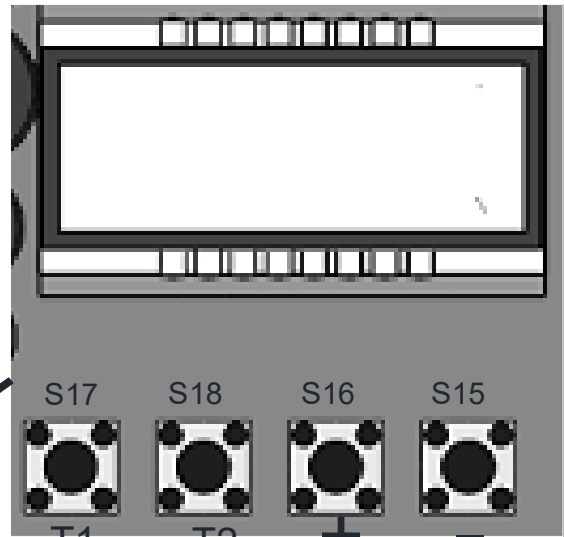





(1) Timer 1 – Mid-open timer: Timer starts counting when door leaves close limit. Door stops after opening for set time. Pressing open again at mid-open position will cause door to open limit.

Timer 2 – Close timer: Timer is active when door stops and is not at close limit.



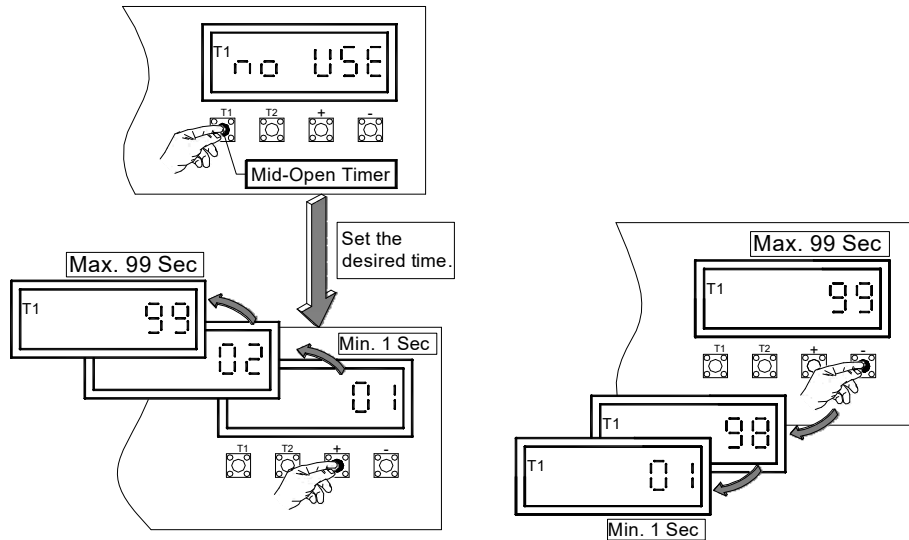

(2) Standard Mode: Cycle counter

(3) To Set Timer 1 (Mid-open Timer):

- Press  and hold for 5 seconds. Display will flash.
- Use  or  to increase or to decrease time.
- Press  to save setting. Without pressing, no adjustment is saved.



(4) To Set Timer 2 (Reclose Timer):

- Press  and hold for 5 seconds. Display will flash.
- Use  or  to increase or to decrease time.
- Press  to save setting. Without pressing, no adjustment is saved.

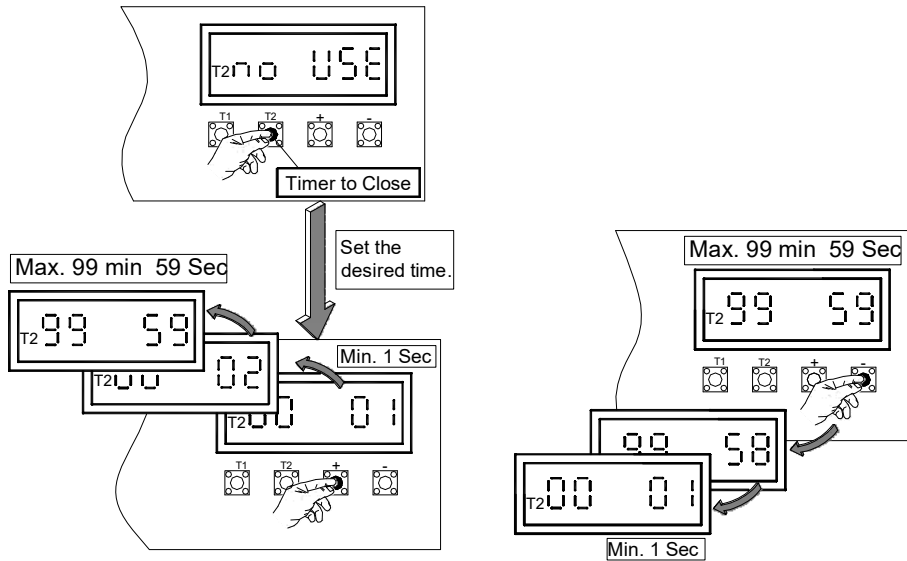

D. LCD Display Instruction:

Display	Status	Display	Status
	T1 setting		Door closing
	T2 setting		Door opening
	T1 or T2 setting completed		

E. Light Indication:

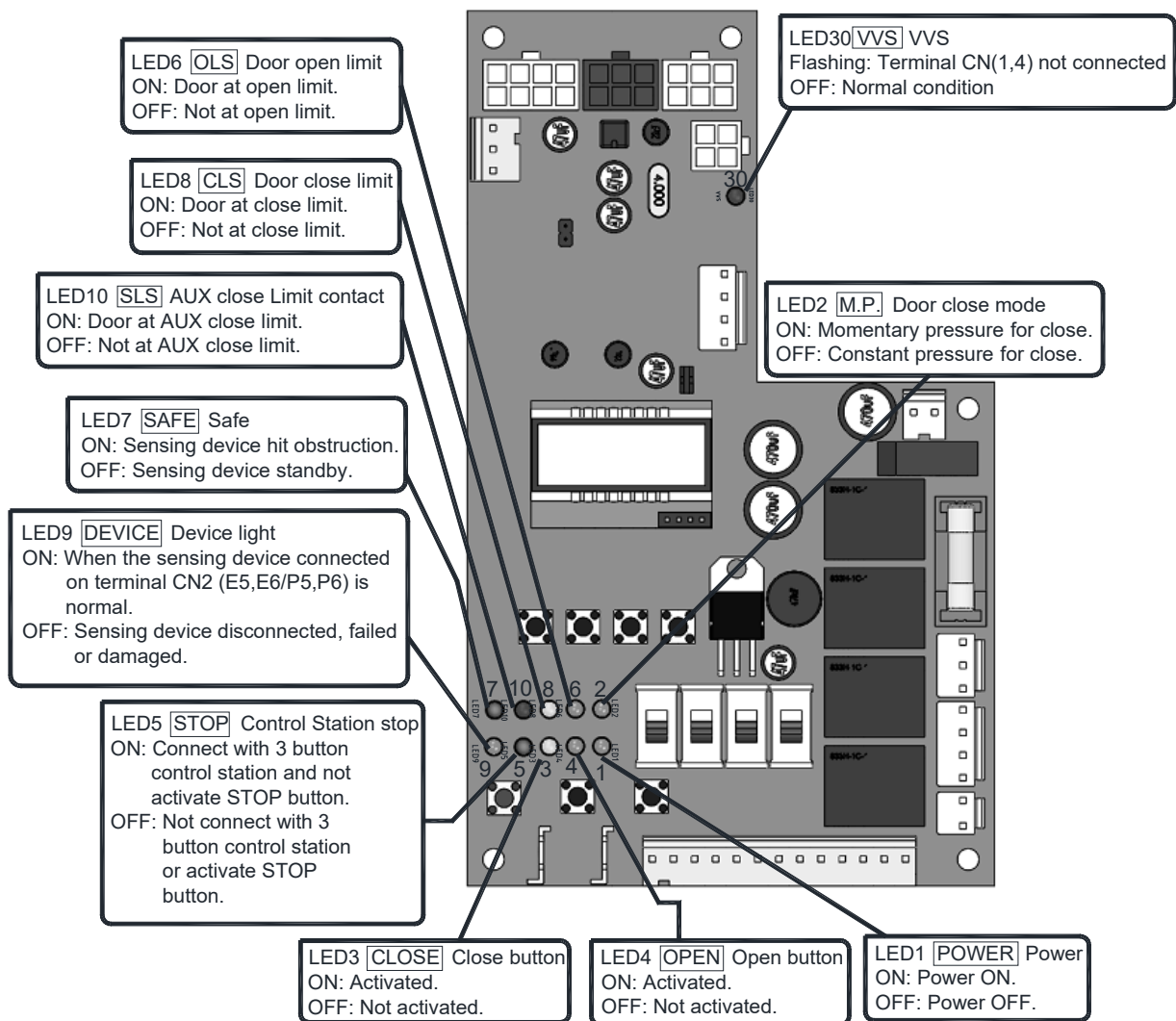

F. Intrinsically Safe Connections:

Note:

- I.S Box for connection of NEMA 1 devices only.
- All the input signals must be in the form of dry contact.

INTEGRATED CONTROL BOX

FG

THE NUMBER OF USED INPUT CHANNELS ARE SUBJECT TO FUNCTIONS BEEN SELECTED FOR I.S OUTPUT IN THE FIELD WIRING. INPUT/OUTPUT CHANNELS ARRANGEMENT CAN BE DETERMINED BY THE MANUFACTURER PER FUNCTION ORIENTATION

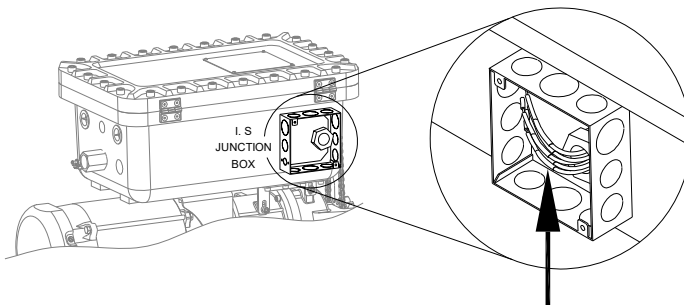
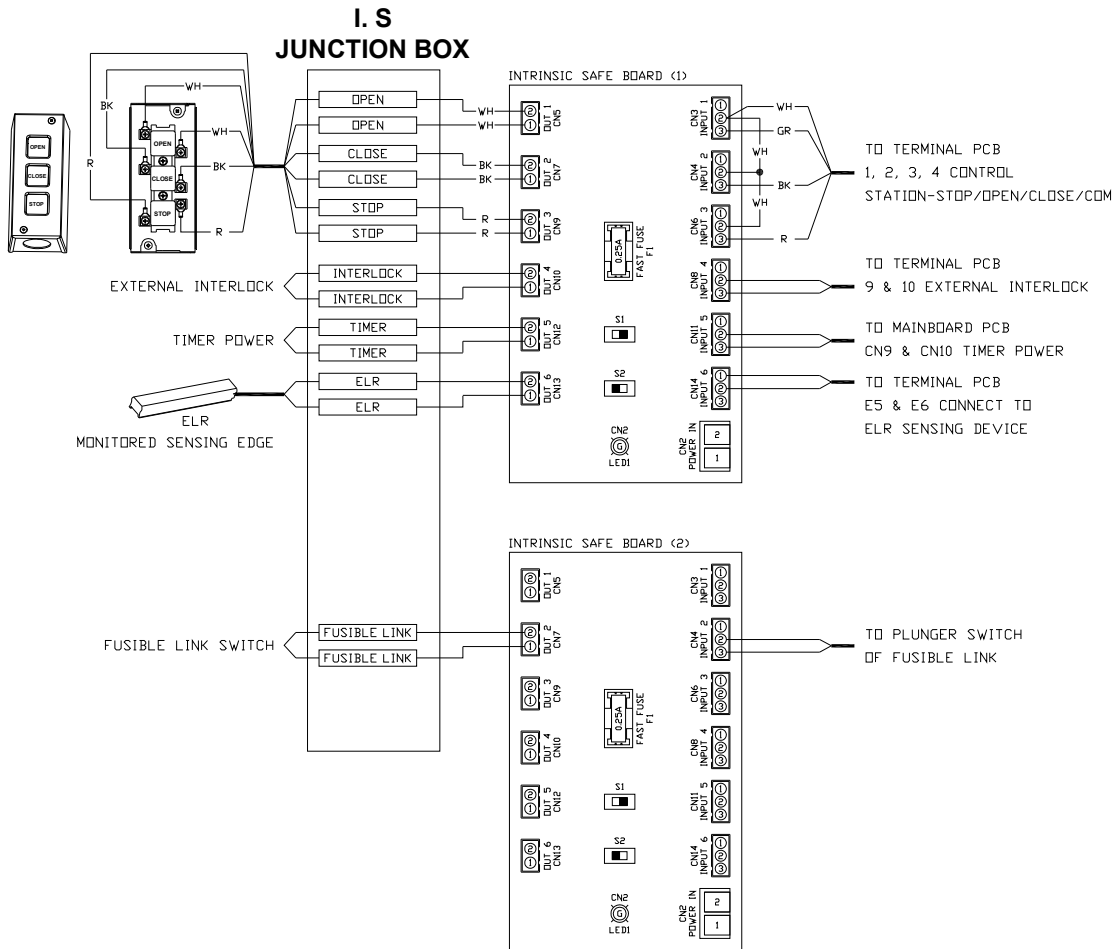

3-V-R-017

Follow the instructions of the wire sleeves for external devices connections.

1. Associated Apparatus Entity Parameters :

$$\begin{aligned} \text{Voc (or Uo)} &= \underline{30} \text{ V dc} \\ \text{Isc (or Io)} &= \underline{5.48} \text{ mA} \\ \text{Po} &= \underline{41.14} \text{ W} \\ \text{Ca (or Co)} &= \underline{0.066} \text{ }\mu\text{F} \\ \text{La (or Lo)} &= \underline{149} \text{ mH} \end{aligned}$$

2. Selected intrinsically safe equipment must be third party listed as intrinsically safe for the application, and have intrinsically safe entity parameters conforming with Table 1 below.

TABLE 1 :

<u>I.S. Equipment</u>	<u>Associated Apparatus</u>
V max (or Ui) \geq	<u>30</u> V dc
I max (or Ii) \geq	<u>5.5</u> mA
P max, Pi \geq	<u>32</u> mW
Ci + Ccable \leq	<u>0.066</u> μF
Li + Lcable \leq	<u>149</u> mH

3. External earthing connection must use minimum wire size of 14AWG.

4. Installation of intrinsically safe electrical equipment and wiring must in accordance with the National Electrical Code (NFPA 70, Article 504 and CSA C22.1, Section 18).

5. Capacitance and inductance of the field wiring from the intrinsically safe equipment to the associated apparatus shall be calculated and must be included in the system calculations as shown in Table 1. Cable capacitance, Ccable, plus intrinsically safe equipment capacitance, Ci must be less than the marked capacitance, Ca (or Co), shown on any associated apparatus used. The same applies for inductance (Lcable, Li and La or Lo, respectively).

Where the cable capacitance and inductance per foot are not known, the following values shall be used : Ccable = 60 pF/ft., Lcable = 0.2 $\mu\text{H/ft.}$

6. This associated apparatus has not been evaluated for use in combination with another associated apparatus.

7. For installations in which both the Ci and Li of the intrinsically safe apparatus exceeds 1% of the Ca (or Co) and La (or Lo) parameters of the associated apparatus (excluding the cable), then 50% of Ca (or Co) and La (or Lo) parameters are applicable and shall not be exceeded. The reduced capacitance shall not be greater than 1 μF for Groups C and/or D.

The values of Ca (or Co) and La (or Lo) determined by this method shall not be exceeded by the sum of all of Ci plus cable capacitances and the sum of all of the Li plus cable inductances in the circuit respectively.

3-V-R-017

2022.03.03

G. Non-intrinsically Safe Connections:

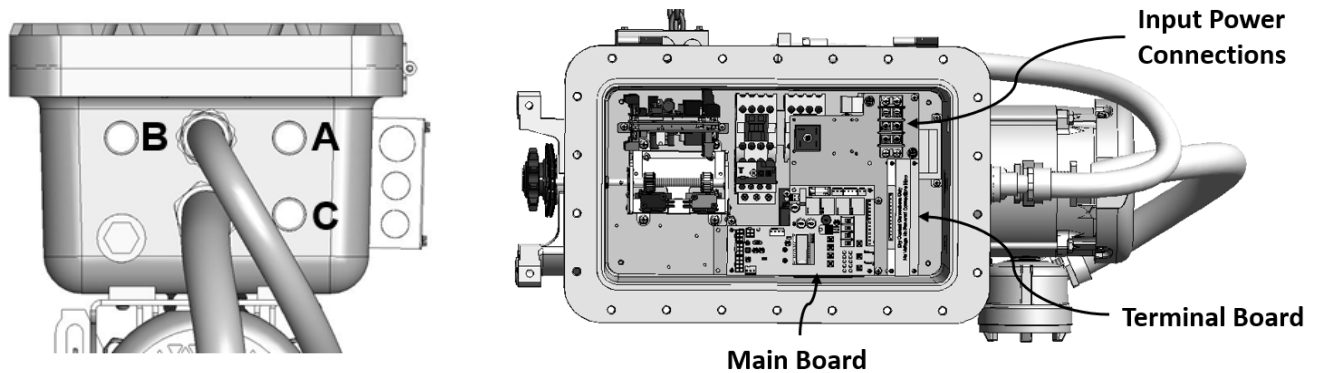

Wiring through the holes:

No.	Size	Connections	Remark
A	3/4" NPT	Input power connections (TB1)	Wired by explosion proof conduit. Using the 3/4"-14 NPT, 5 threads engaged, pitch of thread 1.814 mm conduit and fittings. (Conduit seals must be installed within 18 inches of this enclosure.)
B & C	3/4" NPT	<p>Terminal board (CN2): (1, 2, 3, 4)* : Control station push button (Stop, open, close, com) <i>*Must remove all default wires (1, 2, 3, 4) and then properly insulate before connecting ex-proof control station.</i> (7, 8) : Moving warning signal 24VDC (31, 32) : Non-monitored sensing devices (34, 35) : Power supply 24VDC 0.5A</p> <p>Sensing module(optional): (P5, P6) : Monitored photo eyes</p> <p>Extra limit module(optional): (Open, Close): Open & Close dry contact</p>	<p><u>All devices must be explosion proof.</u></p> <p>Wired by explosion proof conduit.</p> <p>* Two (2) 3/4"-14 NPT, 5 threads engaged, pitch of thread 1.814 mm holes are from default. (Conduit seals must be installed within 18 inches of this enclosure.)</p> <p>*Seal the unused hole with the provided screw plug, which requires tightening torque of 57 ft-lbs (800 kg-cm).</p>

EEN79 1A02G1 L



NEMA 1 DEVICES CONNECTIONS

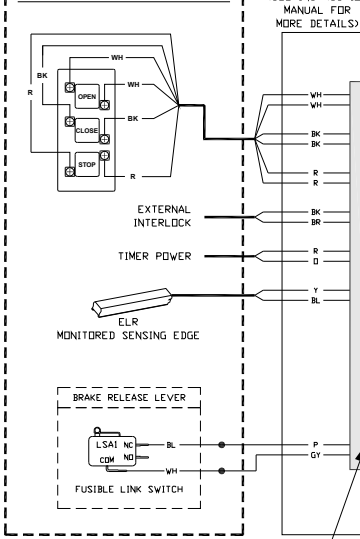

EXPLOSION-PROOF SEAL

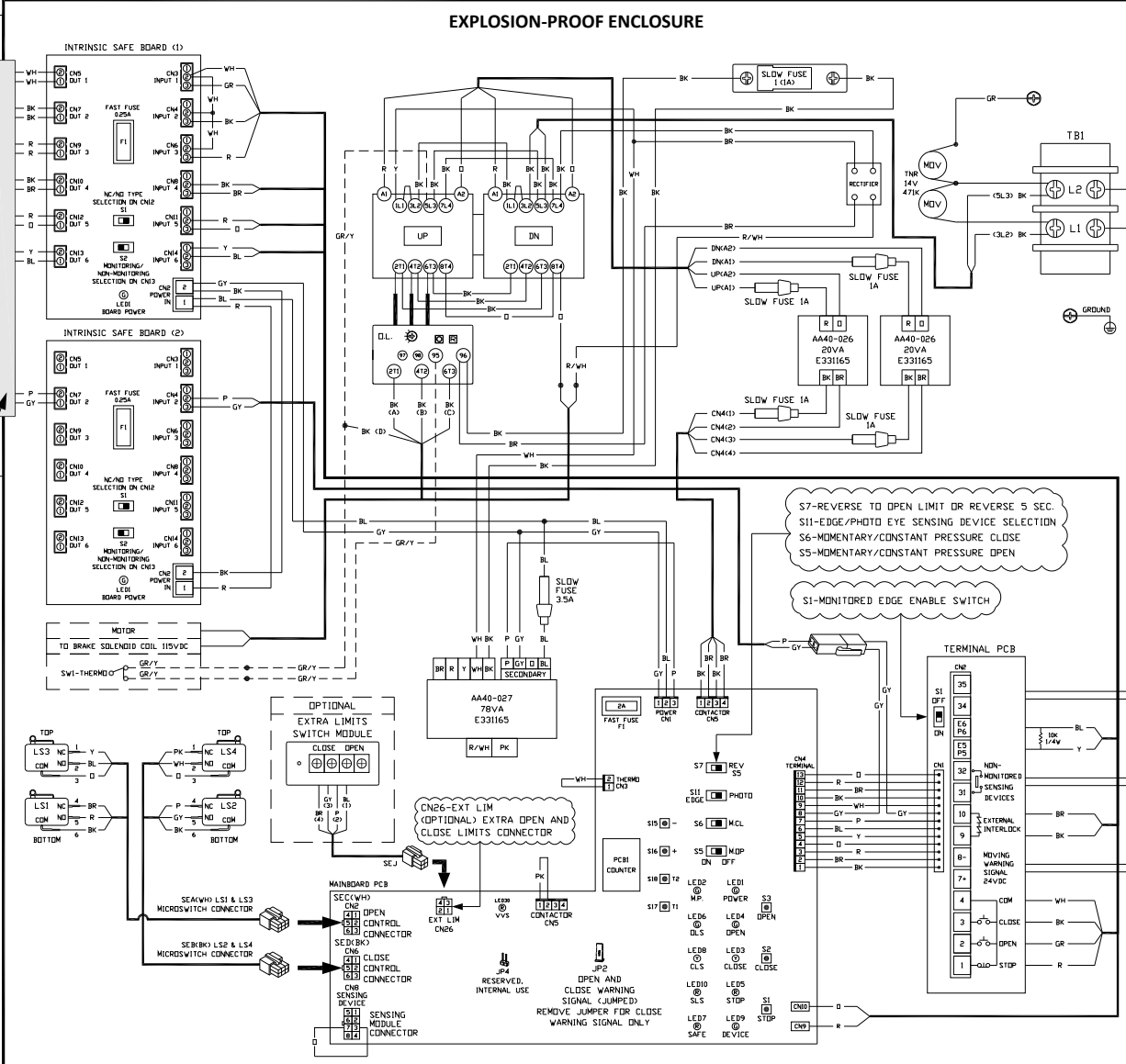
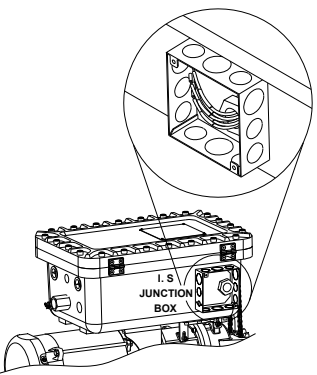

INPUT POWER
115V
1 PHASE

NOTE:
ALL WIRING SHOWN INSIDE
OF THIS BROKEN LINE AREA
MUST RUN THROUGH
EXPLOSION-PROOF
CONDUITS AND FITTINGS.

**NEMA 7 / 9 DEVICES
CONNECTIONS**

(34, 35)
24VAC POWER, MAX. 0.5A

(31, 32)
NON-MONITORED SENSING
DEVICES (N/D DRY CONTACT)

(7, 8)
DOOR MOVING WARNING
SIGNAL 24VDC

(1, 2, 3, 4)
ALTERNATE CONTROL STATION
WIRING
MUST REMOVE ALL DEFAULT
WIRES (1, 2, 3, 4) AND
THEN PROPERLY INSULATE
BEFORE CONNECTING EX-PROOF
CONTROL STATION.

2023.07.10

EEN79 1A02G1 R



NEMA 7/9 DEVICES CONNECTIONS

(1, 2, 3, 4)
 ALTERNATE CONTROL STATION WIRING
 MUST REMOVE ALL DEFAULT WIRES (1, 2, 3, 4) AND THEN PROPERLY INSULATE BEFORE CONNECTING EX-PROOF CONTROL STATION.

(7, 8)
 DDR MOVING WARNING SIGNAL 24VDC

(31, 32)
 NON-MONITORED SENSING DEVICES (N/D DRY CONTACT)

(34, 35)
 24VAC POWER, MAX. 0.5A

NOTE:
 ALL WIRING SHOWN INSIDE OF THIS BROKEN LINE AREA MUST RUN THROUGH EXPLOSION-PROOF CONDUITS AND FITTINGS.

INPUT POWER
 115V
 1 PHASE

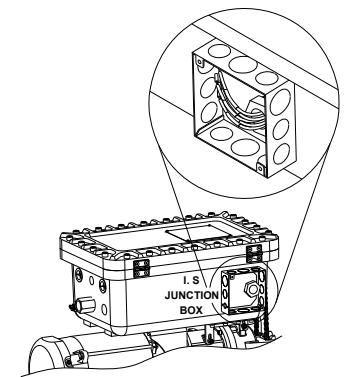
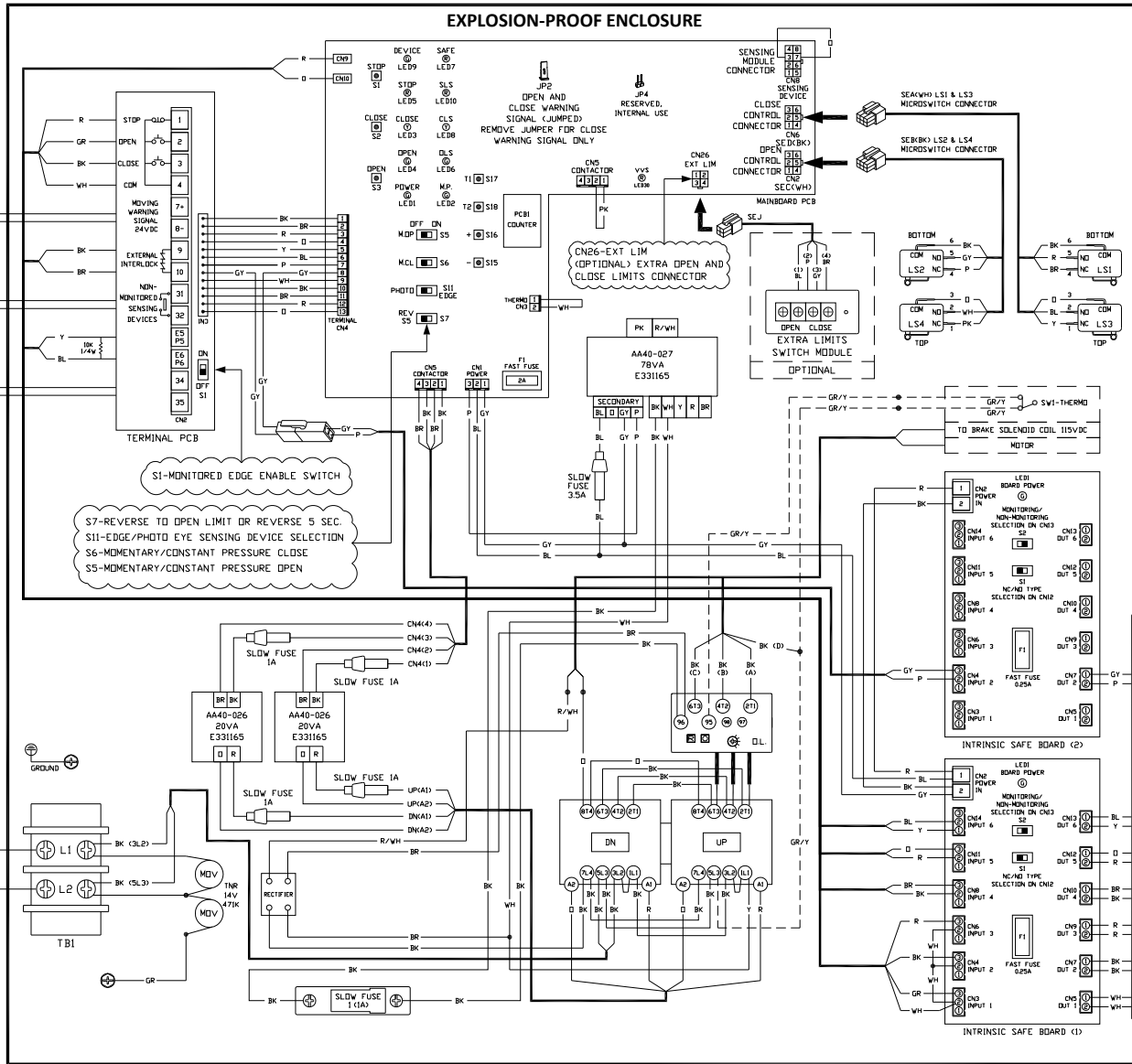

I.S. JUNCTION BOX
 (SEE INSTRUCTION MANUAL FOR MORE DETAILS)

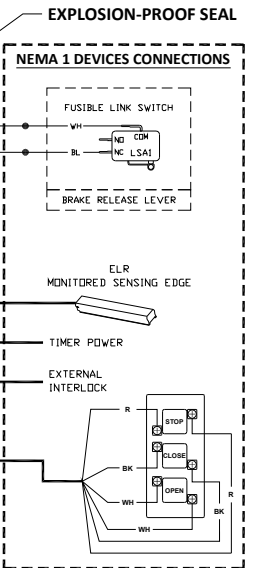

2023.07.10

FHN79 230V 1 PHASE 50/60HZ LH

(60HZ FOR FHN79-5021G1, 7521G1, 10021G1, 15021G1, 20021G1)

(50HZ FOR FHN79-5025G1, 7525G1, 10025G1, 15025G1, 20025G1)

EEN79 2A02G1 L



NEMA 1 DEVICES CONNECTIONS

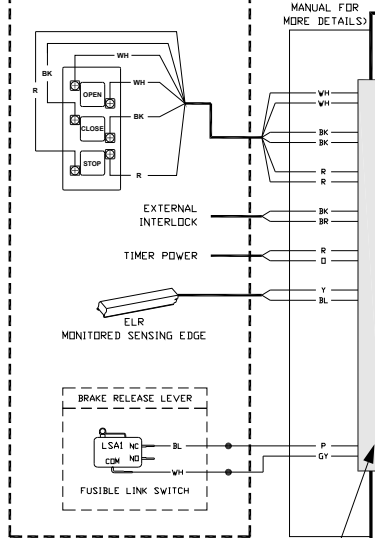

EXPLOSION-PROOF SEAL

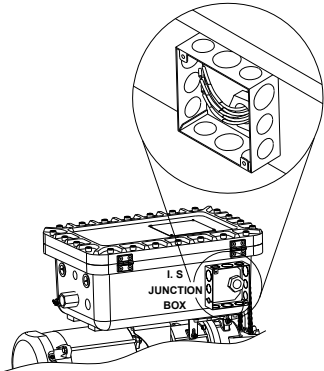

I. S. JUNCTION BXX (SEE INSTRUCTION MANUAL FOR MORE DETAILS)

EXPLOSION-PROOF ENCLOSURE

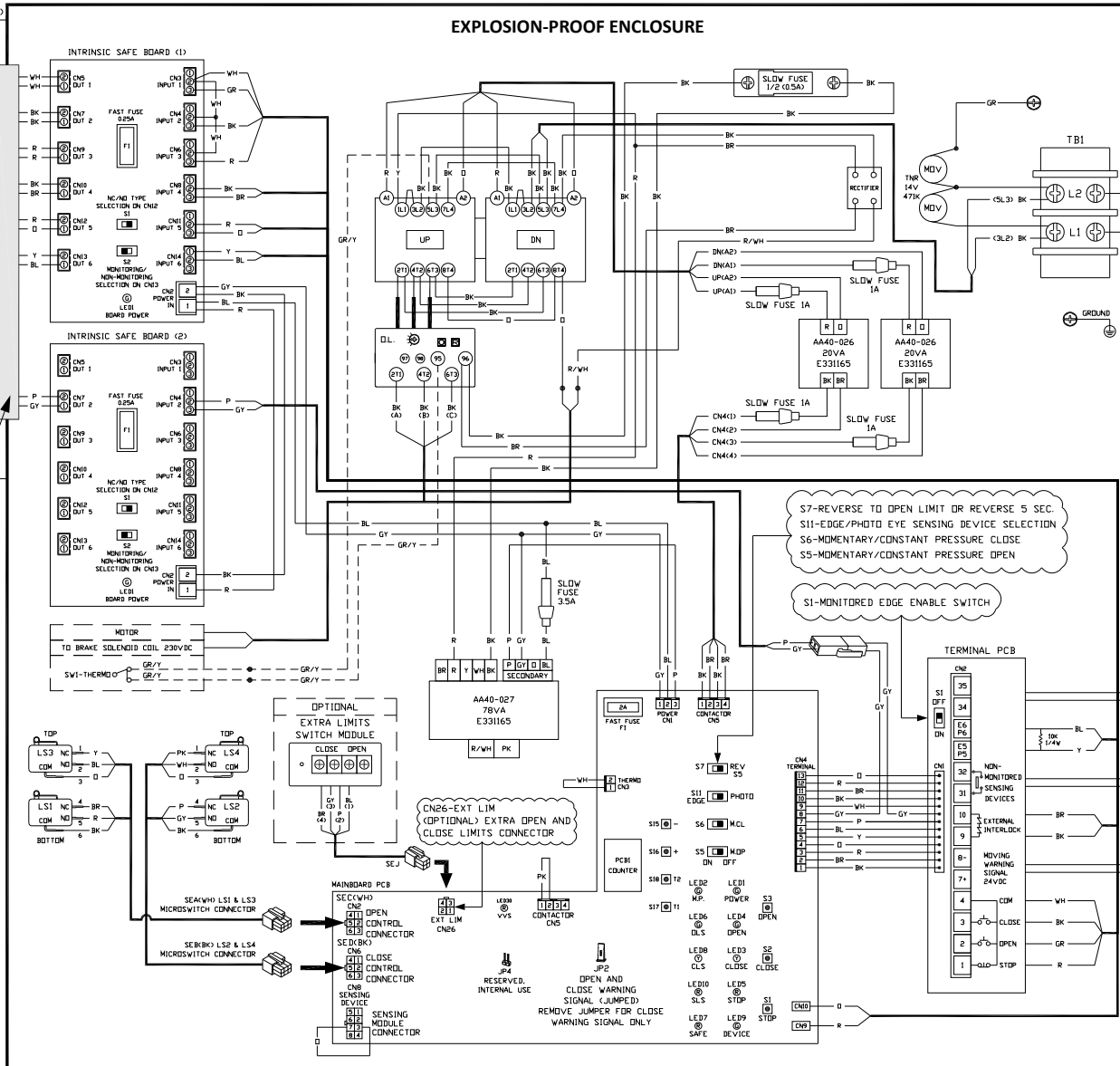

INPUT POWER 230V 1 PHASE

NOTE:
ALL WIRING SHOWN INSIDE OF THIS BROKEN LINE AREA MUST RUN THROUGH EXPLOSION-PROOF CONDUITS AND FITTINGS.

NEMA 7 / 9 DEVICES CONNECTIONS

- (34, 35) 24VAC POWER, MAX. 0.5A
- (31, 32) NON-MONITORED SENSING DEVICES (N/D DRY CONTACT)
- (7, 8) DOOR MOVING WARNING SIGNAL 24VDC
- (1, 2, 3, 4) ALTERNATE CONTROL STATION WIRING MUST REMOVE ALL DEFAULT WIRES (1, 2, 3, 4) AND THEN PROPERLY INSULATE BEFORE CONNECTING EX-PROOF CONTROL STATION.

2023.07.10

FHN79 230V 1 PHASE 50/60HZ RH

(60HZ FOR FHN79-5021G1, 7521G1, 10021G1, 15021G1, 20021G1)

(50HZ FOR FHN79-5025G1, 7525G1, 10025G1, 15025G1, 20025G1)

EEN79 2A02G1 R

SCAN FOR COLOR VERSION



NEMA 7 / 9 DEVICES CONNECTIONS

(1, 2, 3, 4)
ALTERNATE CONTROL STATION WIRING
MUST REMOVE ALL DEFAULT WIRES (1, 2, 3, 4) AND THEN PROPERLY INSULATE BEFORE CONNECTING EX-PROOF CONTROL STATION.

(7, 8)
DDR MOVING WARNING SIGNAL 24VDC

(31, 32)
NON-MONITORED SENSING DEVICES (N/D DRY CONTACT)

(34, 35)
24VAC POWER, MAX. 0.5A

NOTE:
ALL WIRING SHOWN INSIDE OF THIS BROKEN LINE AREA MUST RUN THROUGH EXPLOSION-PROOF CONDUITS AND FITTINGS.



INPUT POWER
230V
1 PHASE

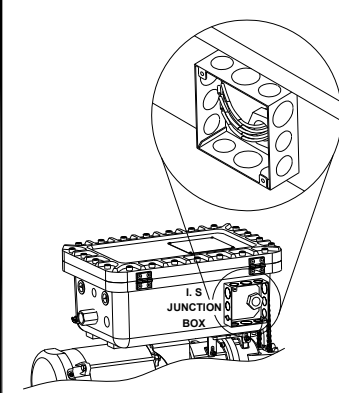
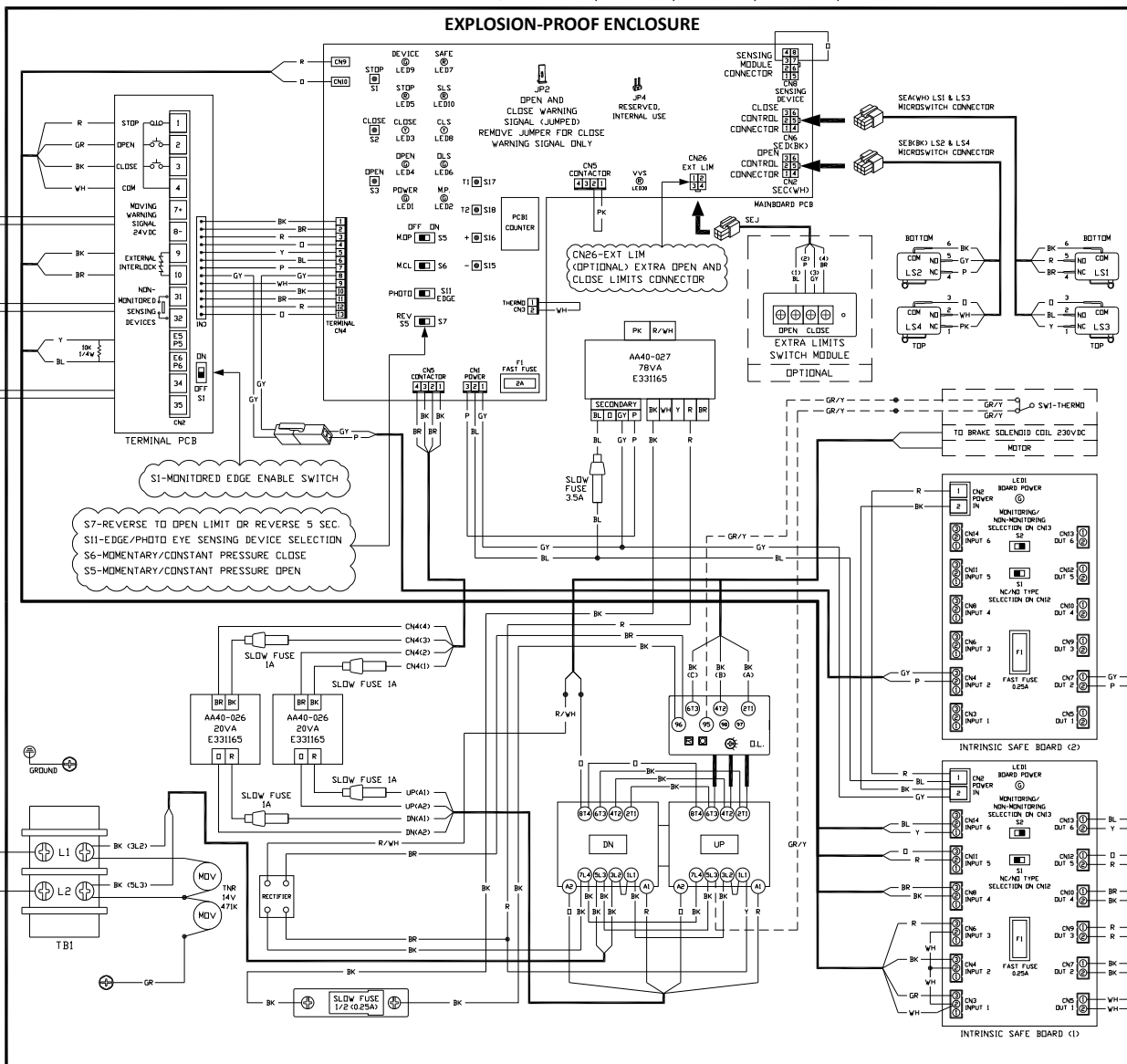

I.S. JUNCTION BOX (SEE INSTRUCTION MANUAL FOR MORE DETAILS)

EXPLOSION-PROOF SEAL

NEMA 1 DEVICES CONNECTIONS

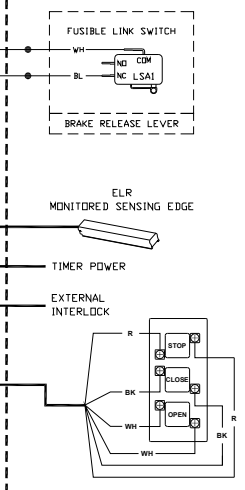

2023.07.10

FHN79 208V/230V 3 PHASE 50/60HZ LH
 (FOR FHN79-5023G1, 7523G1, 10023G1, 15023G1, 20023G1)

EEN79 3A02G1 L



NEMA 1 DEVICES CONNECTIONS

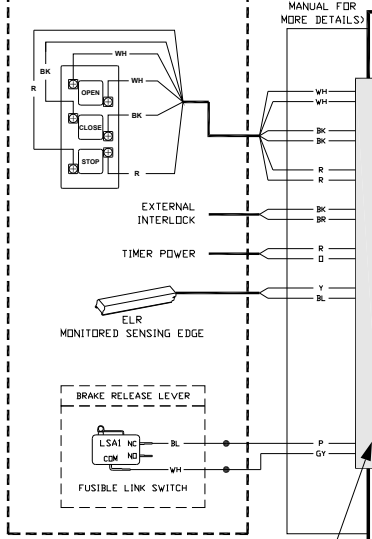

EXPLOSION-PROOF SEAL

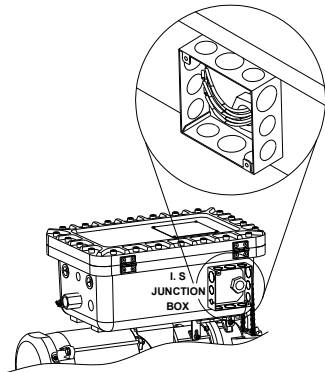

EXPLOSION-PROOF ENCLOSURE

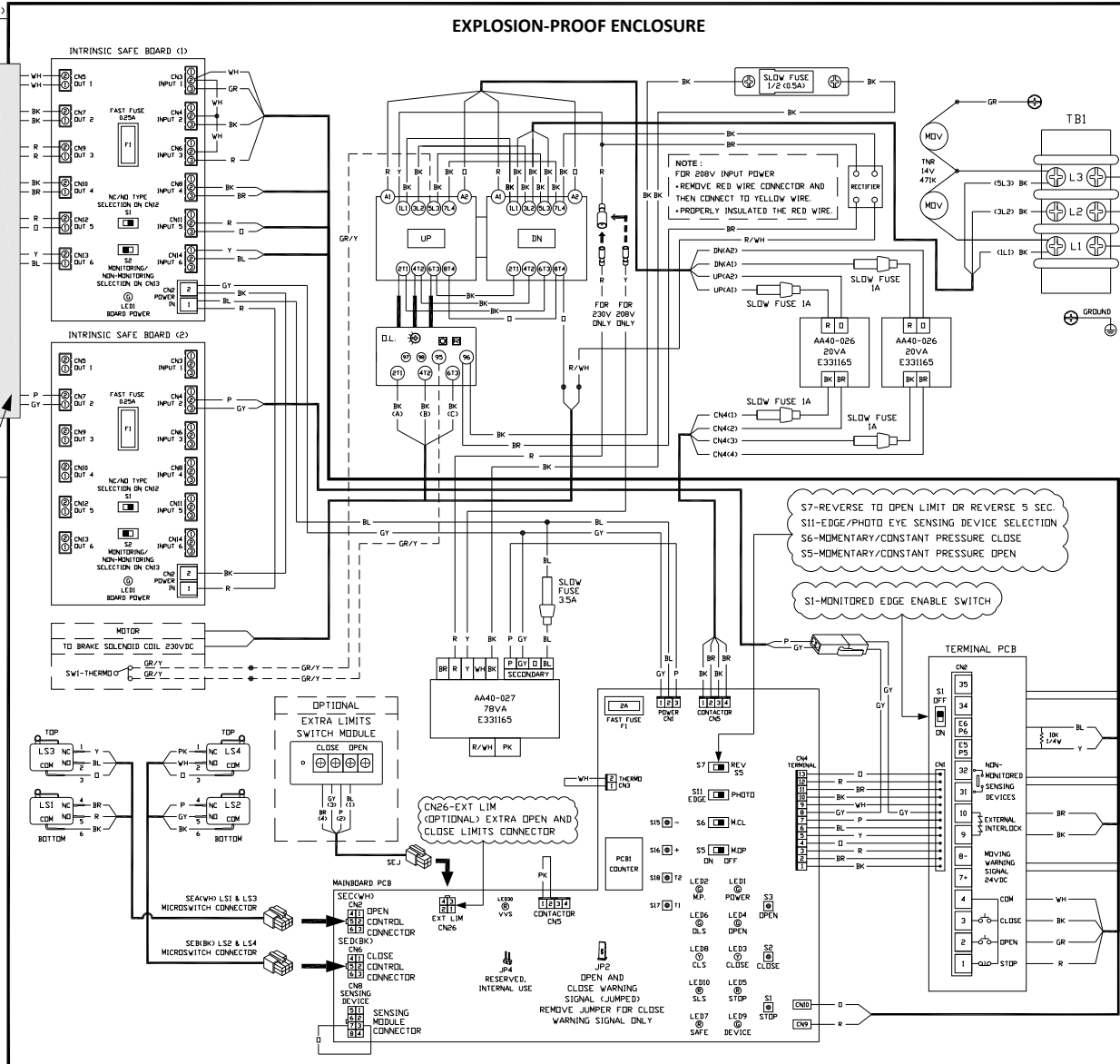

INPUT POWER
 208V / 230V
 3 PHASE

NOTE:
 ALL WIRING SHOWN INSIDE OF THIS BROKEN LINE AREA MUST RUN THROUGH EXPLOSION-PROOF CONDUITS AND FITTINGS.

NEMA 7 / 9 DEVICES CONNECTIONS

- (34, 35) 24VDC POWER, MAX. 0.5A
- (31, 32) NON-MONITORED SENSING DEVICES (N/O DRY CONTACT)
- (7, 8) DOOR MOVING WARNING SIGNAL 24VDC
- (1, 2, 3, 4) ALTERNATE CONTROL STATION WIRING
 MUST REMOVE ALL DEFAULT WIRES (1, 2, 3, 4) AND THEN PROPERLY INSULATE BEFORE CONNECTING EX-PROOF CONTROL STATION.

2023.07.10

FHN79 208V/230V 3 PHASE 50/60HZ RH
 (FOR FHN79-5023G1, 7523G1, 10023G1, 15023G1, 20023G1)

EEN79 3A02G1 R



NEMA 7 / 9 DEVICES CONNECTIONS

(1, 2, 3, 4)
 ALTERNATE CONTROL STATION WIRING
 MUST REMOVE ALL DEFAULT WIRES (1, 2, 3, 4) AND THEN PROPERLY INSULATE BEFORE CONNECTING EX-PROOF CONTROL STATION.

(7, 8)
 DOOR MOVING WARNING SIGNAL 24VDC

(31, 32)
 NON-MONITORED SENSING DEVICES (N/O DRY CONTACT)

(34, 35)
 24VAC POWER, MAX. 0.5A

NOTE:
 ALL WIRING SHOWN INSIDE OF THIS BROKEN LINE AREA MUST RUN THROUGH EXPLOSION-PROOF CONDUITS AND FITTINGS.

INPUT POWER
 208V / 230V
 3 PHASE

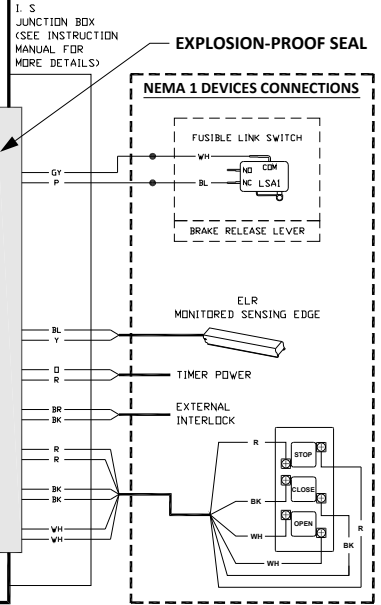
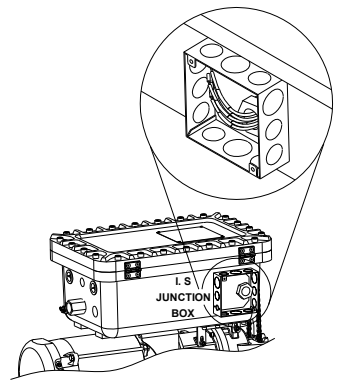
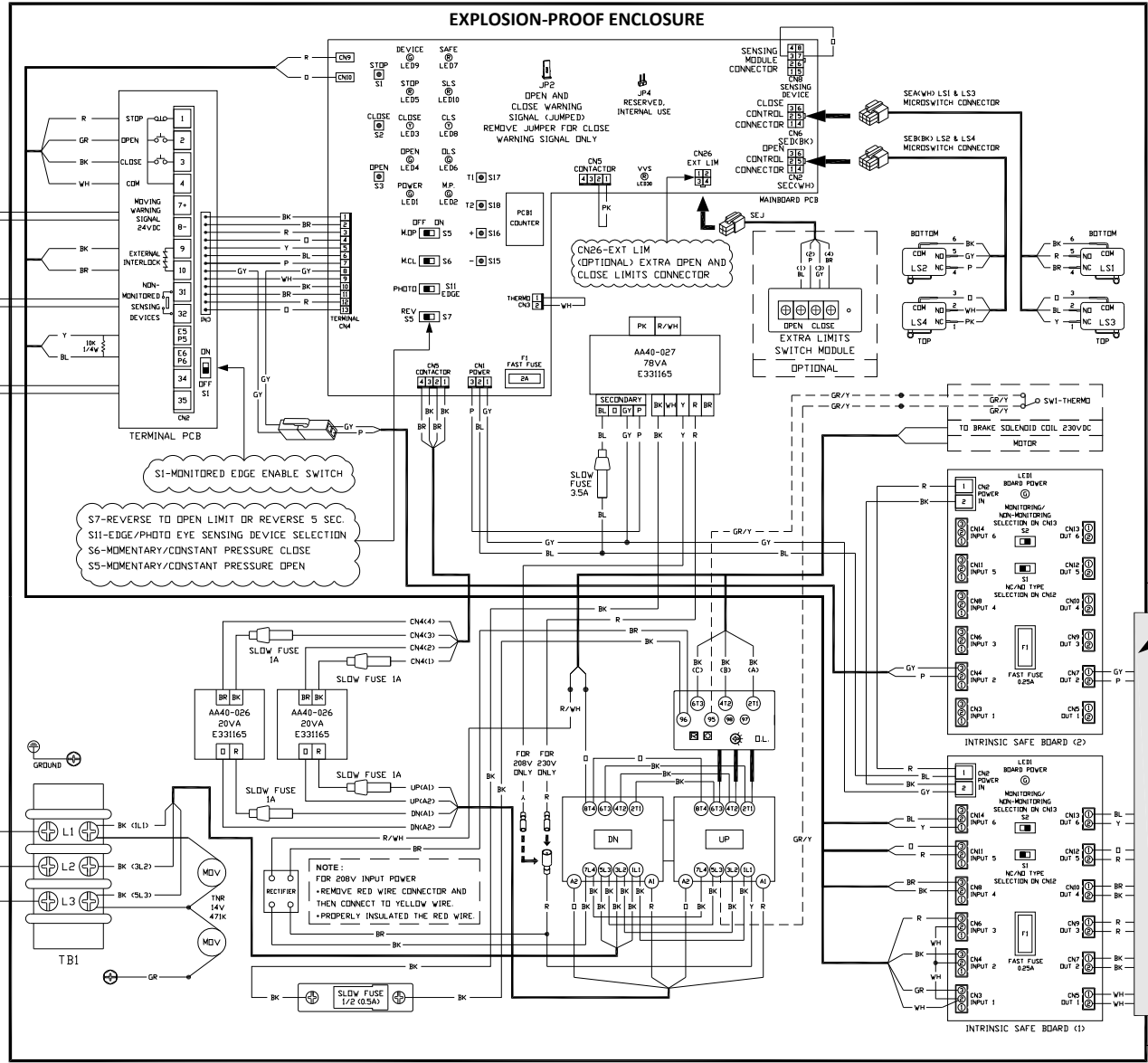

2023.07.10



NEMA 1 DEVICES CONNECTIONS

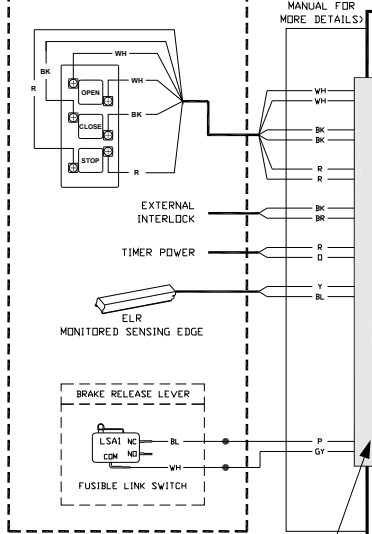

EXPLOSION-PROOF SEAL

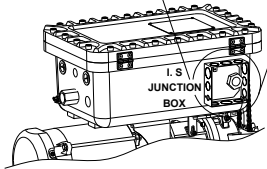
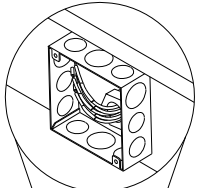

I.S. JUNCTION BOX (SEE INSTRUCTION MANUAL FOR MORE DETAILS)

EXPLOSION-PROOF ENCLOSURE

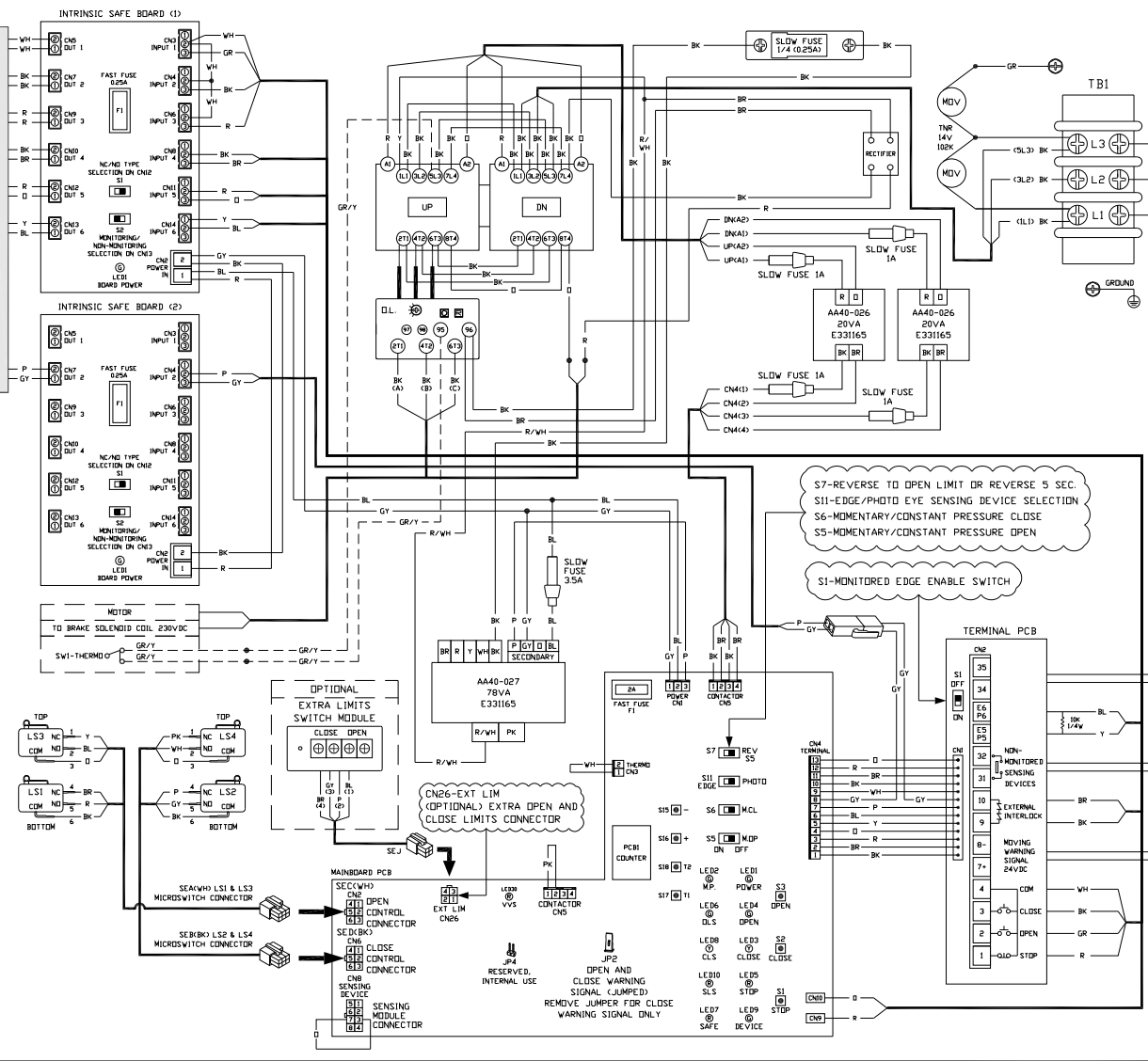

INPUT POWER 460V 3 PHASE

NOTE:
 ALL WIRING SHOWN INSIDE OF THIS BROKEN LINE AREA MUST RUN THROUGH EXPLOSION-PROOF CONDUITS AND FITTINGS.

NEMA 7 / 9 DEVICES CONNECTIONS

- (34, 35) 24VDC POWER, MAX. 0.5A
- (31, 32) NON-MONITORED SENSING DEVICES (N/D DRY CONTACT)
- (7, 8) DOOR MOVING WARNING SIGNAL 24VDC
- (1, 2, 3, 4) ALTERNATE CONTROL STATION WIRING. MUST REMOVE ALL DEFAULT WIRES (1, 2, 3, 4) AND THEN PROPERLY INSULATE BEFORE CONNECTING EX-PROOF CONTROL STATION.

EEN79 4A02G1 R



NEMA 7 / 9 DEVICES CONNECTIONS

(1, 2, 3, 4)
 ALTERNATE CONTROL STATION WIRING
 MUST REMOVE ALL DEFAULT WIRES (1, 2, 3, 4) AND THEN PROPERLY INSULATE BEFORE CONNECTING EX-PROOF CONTROL STATION.

(7, 8)
 DOOR MOVING WARNING SIGNAL 24VDC

(31, 32)
 NON-MONITORED SENSING DEVICES (N/D DRY CONTACT)

(34, 35)
 24VAC POWER, MAX. 0.5A

NOTE:
 ALL WIRING SHOWN INSIDE OF THIS BROKEN LINE AREA MUST RUN THROUGH EXPLOSION-PROOF CONDUITS AND FITTINGS.



INPUT POWER
 460V
 3 PHASE

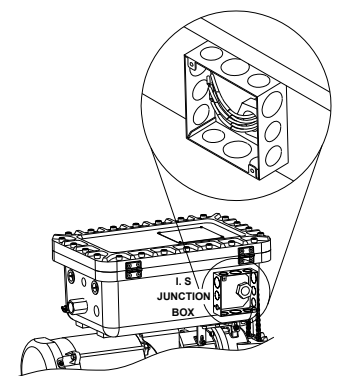
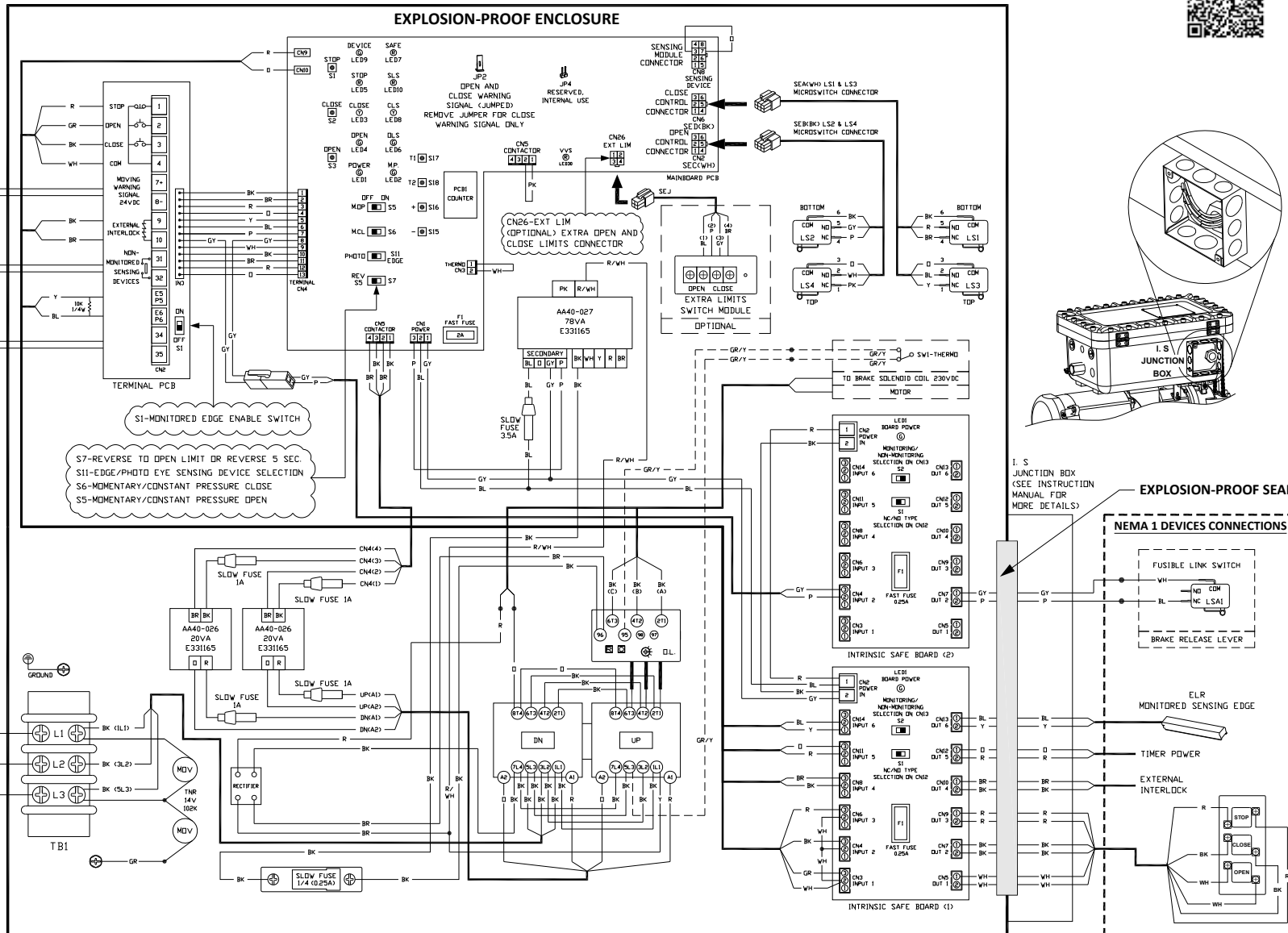

I. S. JUNCTION BDX (SEE INSTRUCTION MANUAL FOR MORE DETAILS)

NEMA 1 DEVICES CONNECTIONS

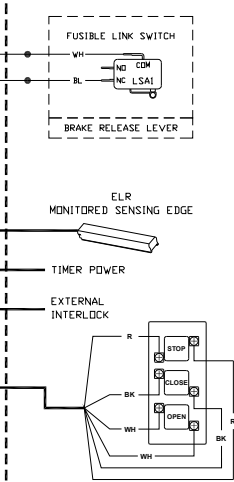

2023.07.10

EEN79 6A02G1 L



NEMA 1 DEVICES CONNECTIONS

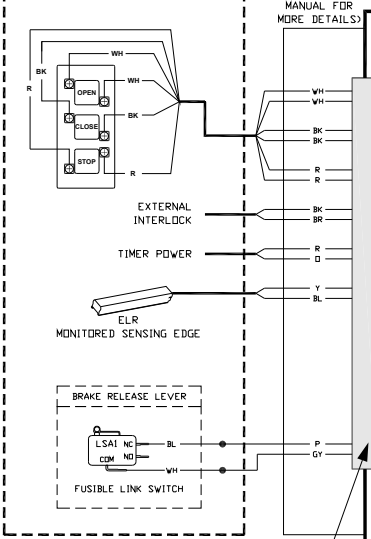

EXPLOSION-PROOF SEAL

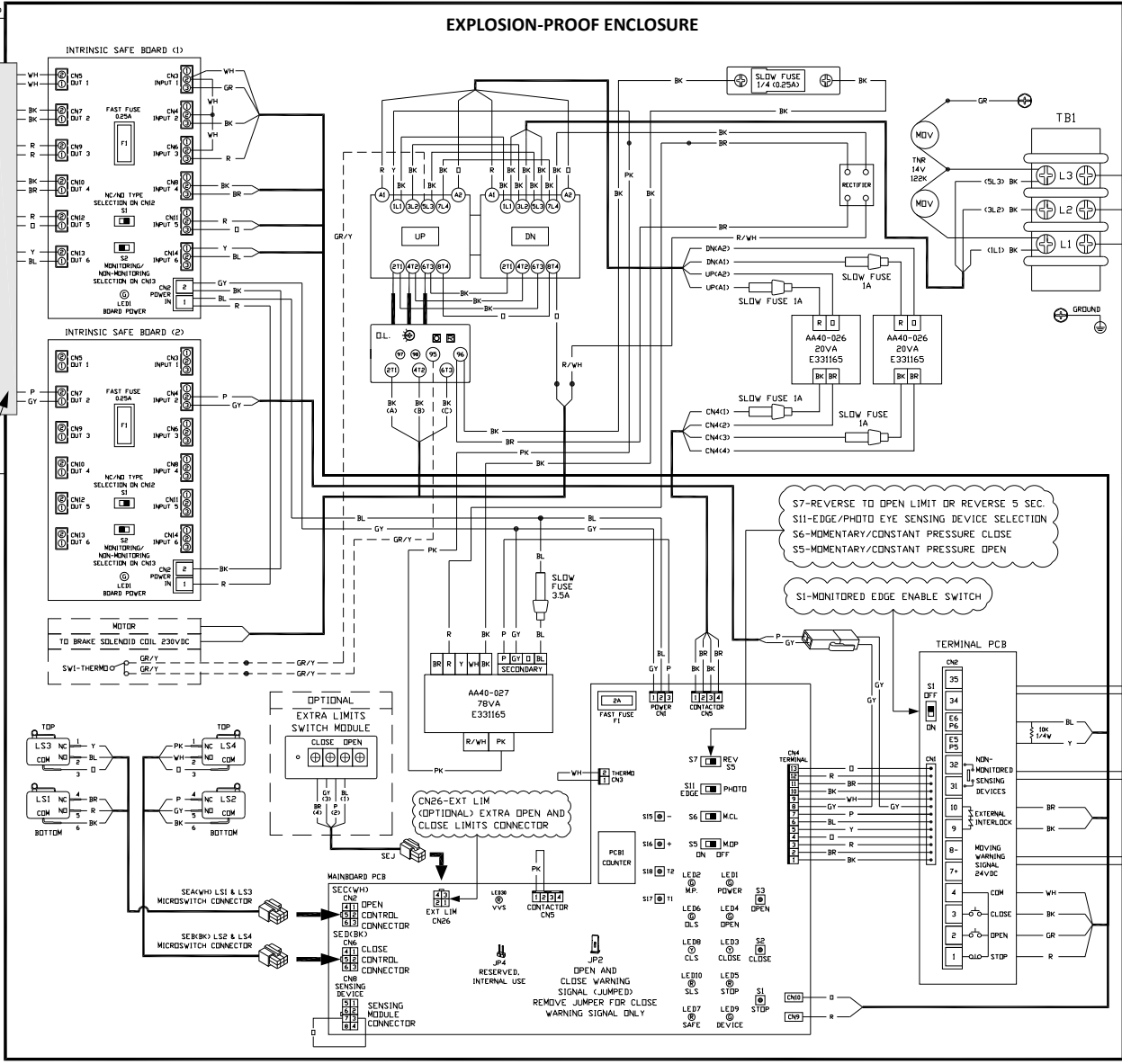
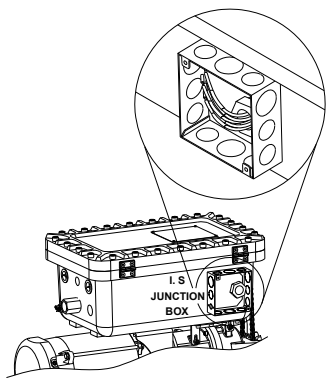

INPUT POWER
575V
3 PHASE

NOTE:
ALL WIRING SHOWN INSIDE OF THIS BROKEN LINE AREA MUST RUN THROUGH EXPLOSION-PROOF CONDUITS AND FITTINGS.

NEMA 7 / 9 DEVICES CONNECTIONS

- (34, 35) → 24VAC POWER, MAX. 0.5A
- (31, 32) → NON-MONITORED SENSING DEVICES (N/O DRY CONTACT)
- (7, 8) → DDR MOVING WARNING SIGNAL 24VDC
- (1, 2, 3, 4) → ALTERNATE CONTROL STATION WIRING
MUST REMOVE ALL DEFAULT WIRES (1, 2, 3, 4) AND THEN PROPERLY INSULATE BEFORE CONNECTING EX-PROOF CONTROL STATION.

2023.07.10

EEN79 6A02G1 R



NEMA 7 / 9 DEVICES CONNECTIONS

- (1, 2, 3, 4) ALTERNATE CONTROL STATION WIRING
 MUST REMOVE ALL DEFAULT WIRES (1, 2, 3, 4) AND THEN PROPERLY INSULATE BEFORE CONNECTING EX-PROOF CONTROL STATION.
- (7, 8) DOOR MOVING WARNING SIGNAL 24VDC
- (31, 32) NON-MONITORED SENSING DEVICES (N/D DRY CONTACT)
- (34, 35) 24VAC POWER, MAX. 0.5A

NOTE:
 ALL WIRING SHOWN INSIDE OF THIS BROKEN LINE AREA MUST RUN THROUGH EXPLOSION-PROOF CONDUITS AND FITTINGS.



INPUT POWER
 575V
 3 PHASE

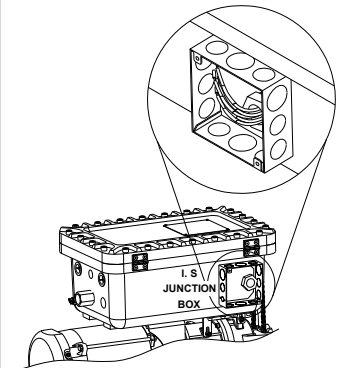
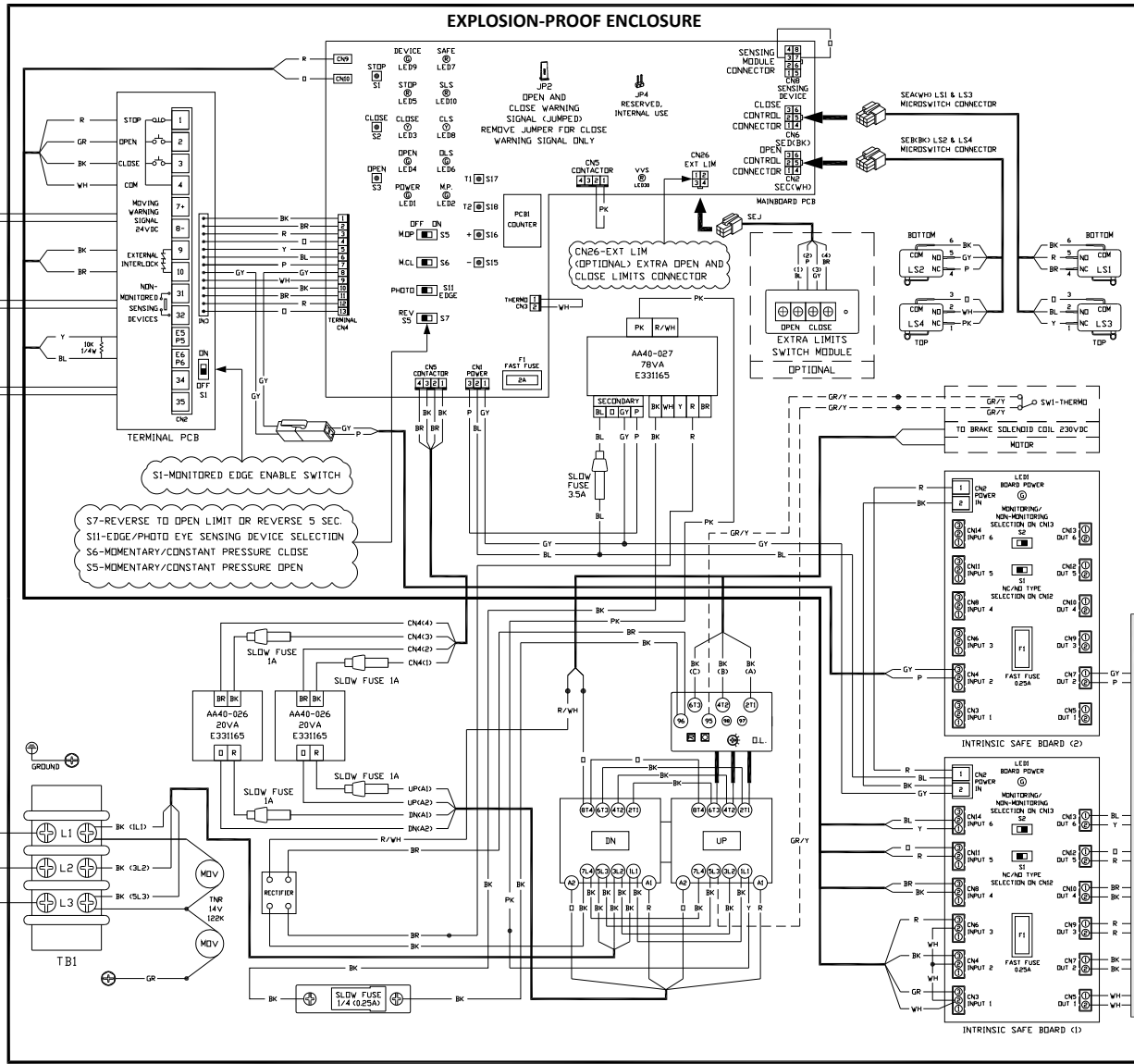

I.S. JUNCTION BOX (SEE INSTRUCTION MANUAL FOR MORE DETAILS)

EXPLOSION-PROOF SEAL

NEMA 1 DEVICES CONNECTIONS

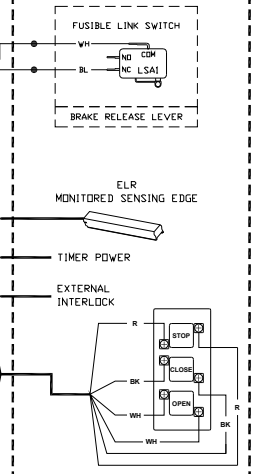

2023.07.10

IMPORTANT SAFETY INSTRUCTIONS

WARNING –To reduce the risk of death or serious injury:

1. READ AND FOLLOW ALL INSTRUCTIONS.
2. Never let children operate or play with door controls. Keep the remote control (where provided) away from children.
3. Personnel should keep away from a door in motion and keep the moving door in sight until it is completely closed or opened. **NO ONE SHOULD CROSS THE PATH OF A MOVING DOOR.**



WARNING

Fire doors could close rapidly at any time and cause death or serious injury.
Do NOT stand in the doorway.

4. Test sensing devices at least once a month. Also test sensing devices after making any adjustments to the close limit. Failure to adjust the operator properly may cause death or serious injury.
5. For operators having an auxiliary release, use caution when using the release if the door is open. Weak or broken springs may cause the door to fall rapidly, causing death or serious injury.
6. **KEEP DOORS PROPERLY OPERATING AND BALANCED.** See door manufacturer's Operation and Maintenance Instructions. An improperly operating or unbalanced door could cause death or serious injury. Have trained door systems technicians make all necessary adjustments and repairs.
7. **SAVE THESE INSTRUCTIONS.**

FUSIBLE LINK CONNECTIONS

- ❖ REMOVE COTTER PIN FROM RELEASE ASSEMBLY AFTER INSTALLATION IS COMPLETE.

Refer to the fire door installation instructions for connection of the release assembly or consult NFPA-80 and the authority having jurisdiction for fusible link location(s) and method.

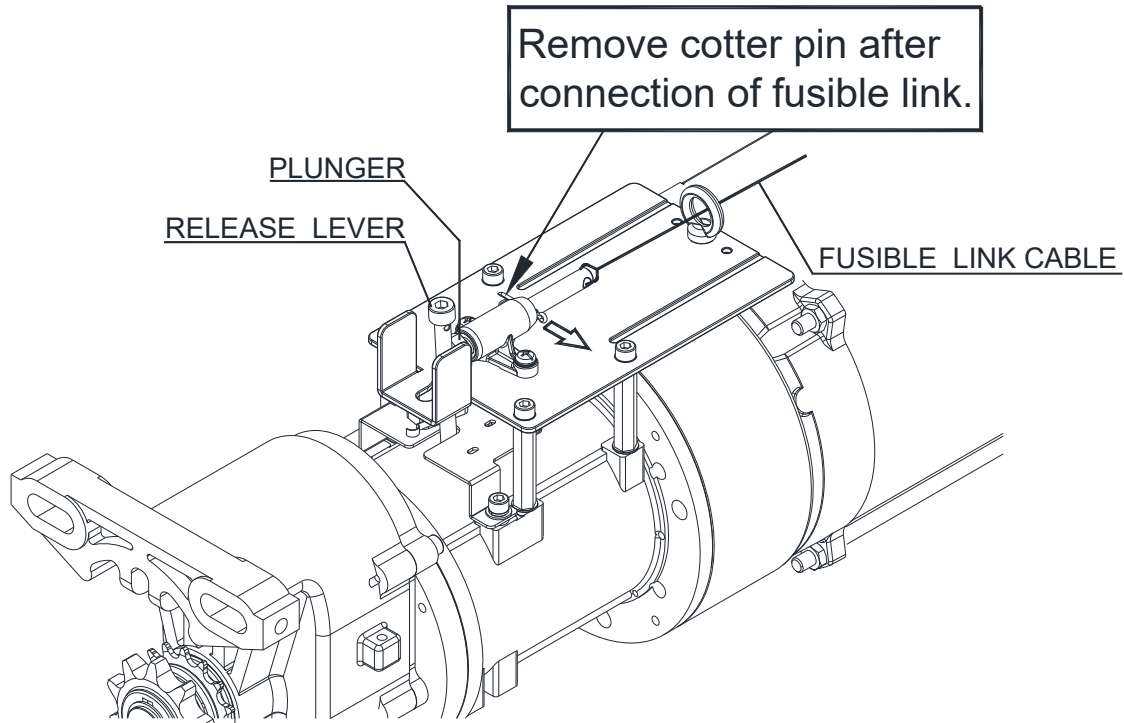

* Illustration only, not drawn to scale. See product for actual details.

OPERATING INSTRUCTIONS

1. If a 3-button control station is used to operate the door, push the "OPEN" button to open the door, push the "CLOSE" button to close the door, push the "STOP" button to stop movement of the door while opening or closing. With constant pressure close operation, removing pressure from the "CLOSE" button will also cause the door to stop.
2. If a key switch control station is used to operate the door, turn the key to the "OPEN" position to open the door, turn the key to the "CLOSE" position to close the door, push the "STOP" button to stop movement of the door while opening or closing. With constant pressure close operation, removing pressure from the "CLOSE" key position will cause the door to stop.

IMPORTANT NOTE: If one or more monitored sensing devices are installed, and determined by the operator to be not functioning properly, the door will either stay open, or re-open if closing. If this occurs, contact a trained door systems technician to make repairs. Until repairs can be made, the door can be opened and closed from the 3-button or key switch control station, but will require constant pressure on the close control to close the door.

EMERGENCY MANUAL OPERATION

This operator has provisions for manually operating the door in case of emergency or power failure. This operator is equipped with an auxiliary chain hoist.

To operate the auxiliary chain hoist:

1. Remove the hand chain from the chain bag.
2. Pull the hand chain to operate the door in the desired direction. (No clutch to engage)

Put the hand chain back into the chain bag before operating the door again electrically.



WARNING

Turn off power to the operator before manually operating the door.



WARNING

Hand chain must be kept inside chain bag when operating electrically.

MAINTENANCE INSTRUCTIONS

The brake is a self-adjusting brake. It is maintenance free. The brake assembly requires no additional adjustments for its lifetime.

If an entrapment protection device is used, i.e. sensing edge or photoelectric sensors, please consult the manufacturer for maintenance instruction.



Disconnect power supply to the operator before servicing.

WARNING

Check the following items at the intervals listed:

CHECK LIST	DESCRIPTION	EVERY 3 MONTHS	EVERY 6 MONTHS	EVERY 12 MONTHS
Drive Chain	Check for excessive slack. Check & adjust as required Lubricate.	●		
Sprockets	Check set screw tightness	●		
Fasteners	Check & tighten as required		●	
Bearings & Shafts	Check for wear & lubricate	●		
Drop-test	Inspect door, drop-test for proper operation and full closure per NFPA-80			●

- ❖ Do not lubricate motor. Motor bearings are rated for continuous operation.
- ❖ Inspect and service whenever a malfunction either door or operator is observed or suspected.
- ❖ Before servicing, always disconnect power supply to the operator.
- ❖ Replace fuses only with those of the same type and rating.
- ❖ All replacement parts must be obtained from the door manufacturer per NFPA-80.



WARNING

Do not place hands or tools in or near the operator when the power is connected or when testing control or sensing devices. Always disconnect power before servicing or adjusting the operator.

APPENDIX 1

Multiple Sensing Devices Connection Instruction

QST-FHN79-EP-ADAPTER-1

Warning: Power OFF When Connecting.

1 Plug back in the jumper connector if no additional modules is used.

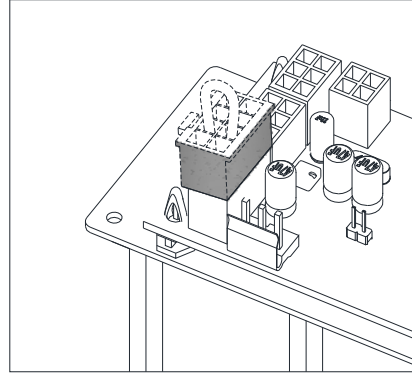
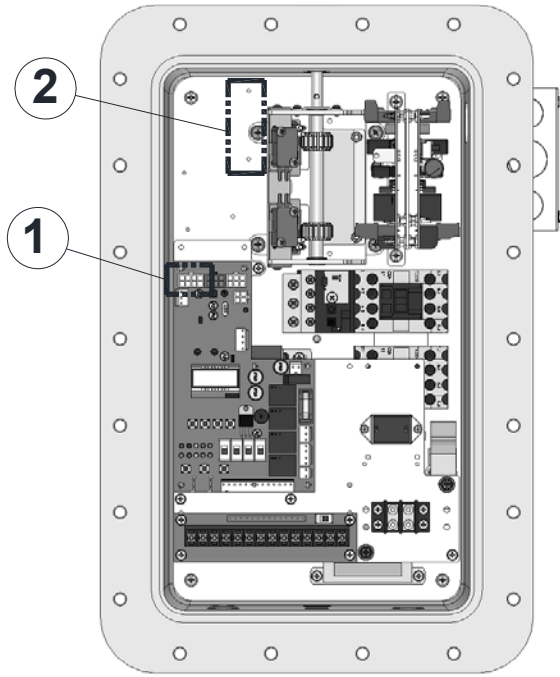

or

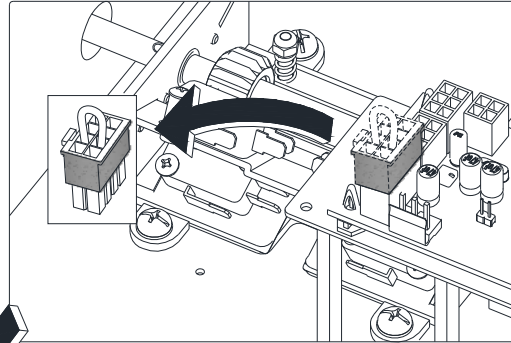

2 Secondary sensing device connects on 1st sensing module.

Unplug the jumper connector to add modules.

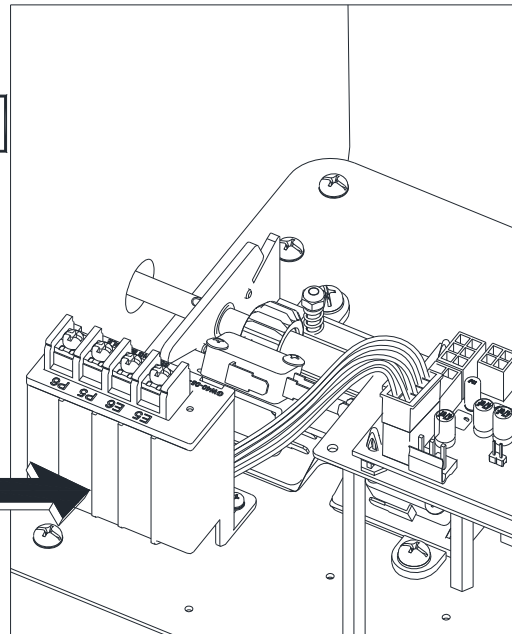
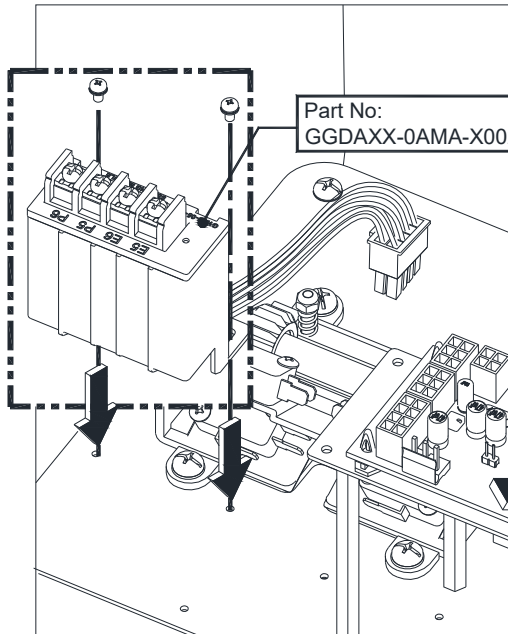

APPENDIX 2

Control Connections Diagrams for NEMA 1 Devices

CCD-N79-V001

Warning !
Remove Jump Pins First - See "A"

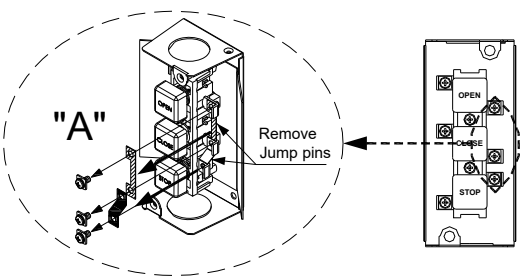

Control Wiring for 3 Button Stations

1 Set of 3 Button Stations

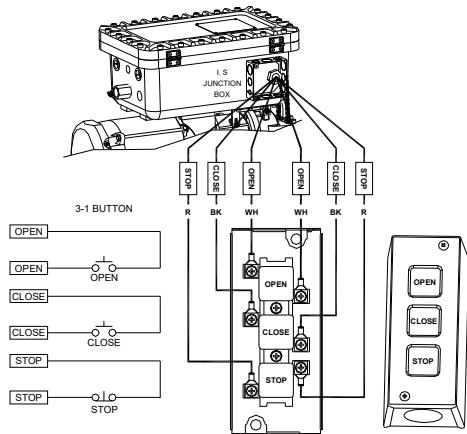

Control Wiring for Key Switch with Stop Button

Key Switch with Stop Button

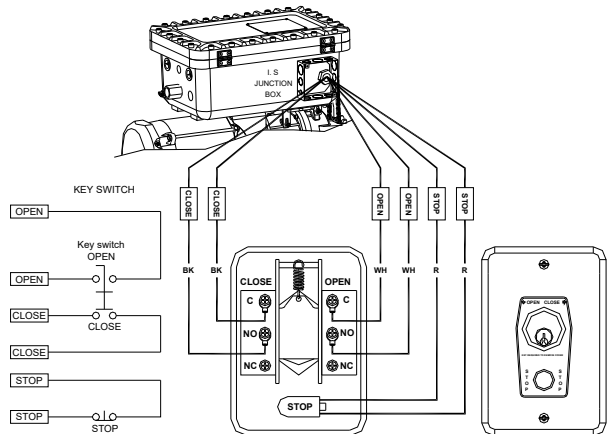

2 Sets of 3 Button Stations

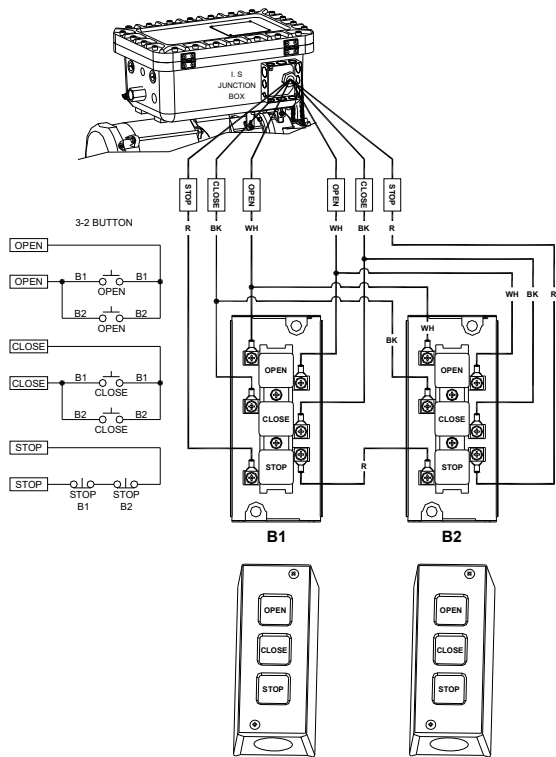

Key Switch (with Stop Button) and 3 Button Stations

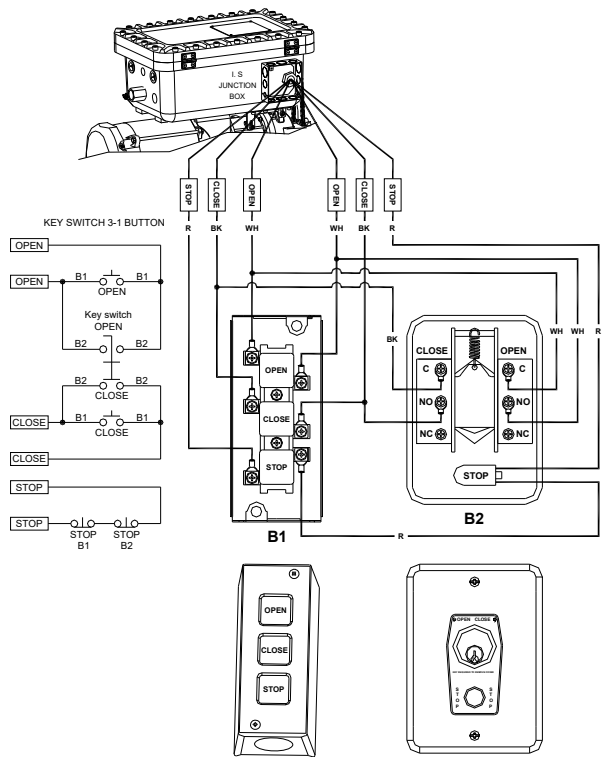

APPENDIX 3

EXTERNAL NEMA 1 TIMER DEFEAT SWITCH CONNECTION

ETDS-N79-V001

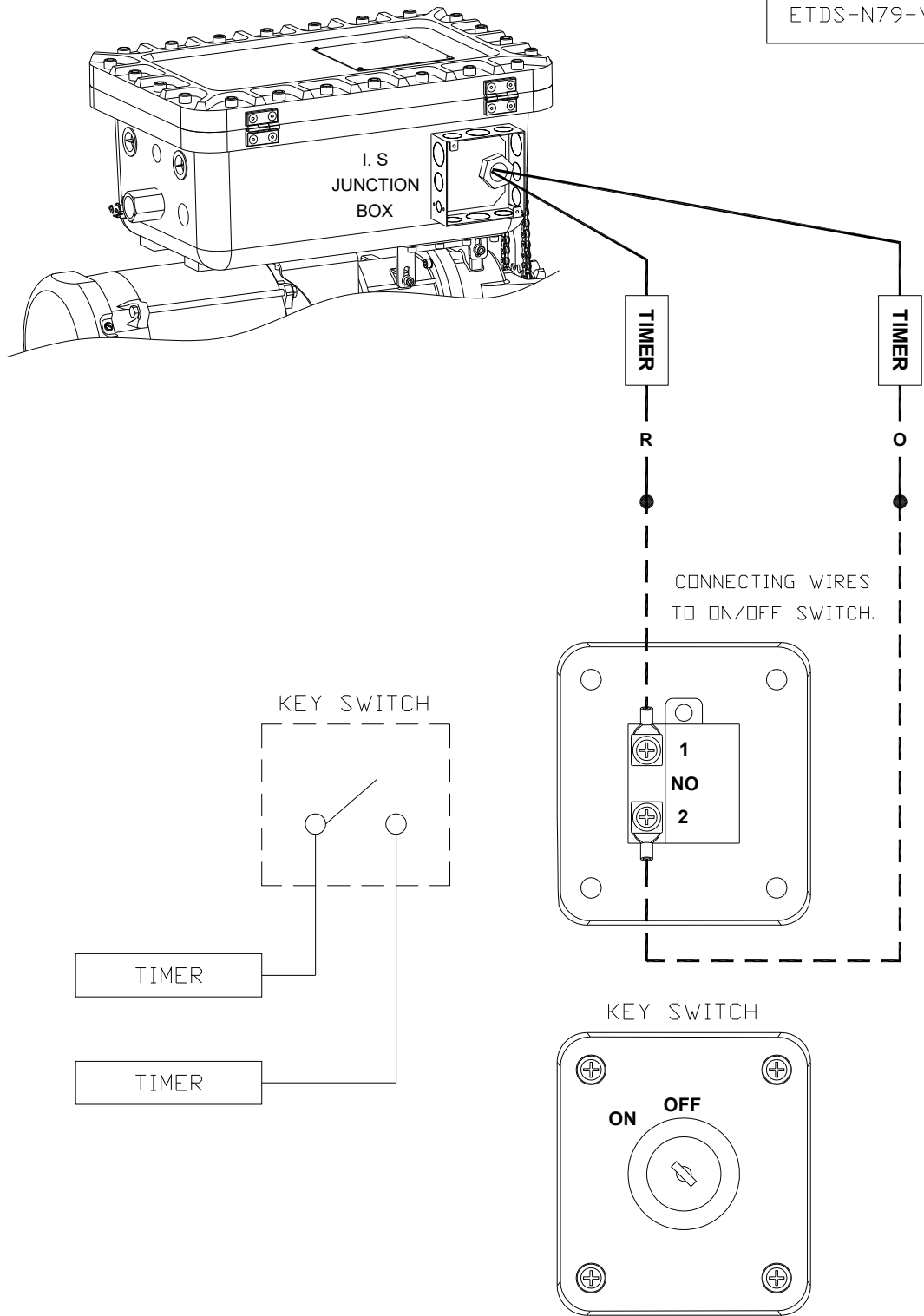

APPENDIX 4

Wiring Change Instruction from 230V to 208V 3 Phase Operator FHN79 Series

FHN79-3P-V02

