



**INSTALLATION INSTRUCTIONS
AND
OPERATION MANUAL**

FSH EP Series

Commercial and Industrial Fire Door Operator

Logic Control

Restricted Duty Fire Door Operators

IMPORTANT INSTALLATION INSTRUCTIONS

WARNING –To reduce the risk of death or serious injury to persons:

1. READ AND FOLLOW ALL INSTALLATION INSTRUCTIONS.



WARNING

WARNING! – Components under **extreme spring tension** can cause death or serious injury.

2. Install only on a properly operating and balanced door. A door that is operating improperly could cause death or serious injury. Have trained door systems technicians make all necessary adjustments and repairs to the door before installing the operator.

Note: Fire door spring tension must be adjusted per the manufacturer's installation instructions to allow for automatic closing during fusible link/alarm activation and drop test. If an operator is connected to an alarm release, the door must also close in a power failure unless closing functions are supported by an approved battery back-up system.)

3. Remove any pull ropes that may be installed on the door.
4. Unless the door operator includes an internal lock sensing system, or external electrical interlocks are installed, remove or make all door locks inoperative, or secure locks in the unlocked position to prevent operation with the locks engaged.
5. Install the door operator at least 8 feet or more above the floor if the operator has exposed moving parts. If the operator must be mounted less 8 ft (2.44 m) above the floor, then exposed moving parts must be protected by covers or guarding. Contact the manufacturer.
6. Install the fusible link cable from the release module on top of the operator per the requirements of NFPA-80.
7. Do not connect the door operator to the source of power until instructed to do so.
8. Locate the control station (open-close-stop push button, key station, or the like):
 - a) within sight of the door, and
 - b) at a minimum height of 5 feet above floors, landings, steps, or any other adjacent walking surface, and
 - c) away from all moving parts of the door
9. Install the Entrapment Warning Placard next to the control station in a prominent location.
10. Make sure the available power supply to be connected to the operator is of the same voltage, frequency, phase and wattage as indicated on the nameplate of the operator.

11. Read and understand the wiring diagram of the operator and the control station and any other equipment to be connected to the operator.
12. Always disconnect power whenever installing or servicing the door operator or door.
13. All wiring must be permanent and comply with National Electrical Code (NEC) and local code requirements.
14. Any change in mounting position may result in a change of operator rotation and consequently in a change of control functions. Consult factory for any changes.
15. If the operator is provided with an auxiliary chain operator, the hand chain must be kept inside the chain bag when operating electrically.
16. For products having a manual release, instruct the end user on the operation of the manual release.

SPECIFICATIONS

MOTOR	
Type:	Restricted cycle duty (30 cycles per hour)
Horsepower:	1/2 hp, 3/4 hp
Speed:	1700 RPM
Voltage:	115, 230 – 1 phase 208/230, 460, 575 – 3 phase 230 volt 3 phase motor is suitable for use with 208 volts (see <i>Wiring Diagrams and Appendix 5 for wiring change instructions</i>)
Current:	See motor nameplate
ELECTRICAL	
Transformer:	24VAC
Wiring Type:	Momentary pressure open, stop, constant pressure close (provided standard), with provision for momentary pressure close*
Limit Adjustment:	Linear driven, fully adjustable screw type cams.
MECHANICAL	
Drive Reduction:	43:1 (1/2 hp), 57:1 (3/4 hp)
Output Shaft Speed:	39 RPM (1/2 hp), 30 RPM (3/4 hp)
Door Speed:	6 - 8" per sec. average (typical)
Brake:	Solenoid actuated brake
Auxiliary Chain Hoist:	Standard
ENTRAPMENT PROTECTION	
Sensing Edge*:	(Optional) Sensing device attached to the bottom edge of the door.
Non-Contact Device*:	(Optional) Photo eye device.
<p>* Per the requirements of UL Standard 325, the door operator is setup for constant pressure to close the door. As an alternative, the door may be provided with at least one <u>monitored</u> sensing device that will reverse the door upon contact with, or upon detecting an obstruction, during closing.</p>	

Notes:

1. A non-contact sensing device (photo eye) can only be used on doors up to 35 ft. wide (or maximum rated range of device if less than 35 ft.). Use a sensing edge to provide entrapment protection on doors over 35 ft. wide.
2. A sensing edge can be used on all doors without size restriction.

TYPES AND SIZES OF DOORS

HP	MAXIMUM AREA - SQ. FT.				
	Doors			Grilles	
	24 ga	22 ga	20 ga	Aluminum	Stainless
1/2	300	300	250	450	250
3/4			300		300

INSTALLATION INSTRUCTIONS

INSTALLATION POSITIONS (for 1/2 hp)

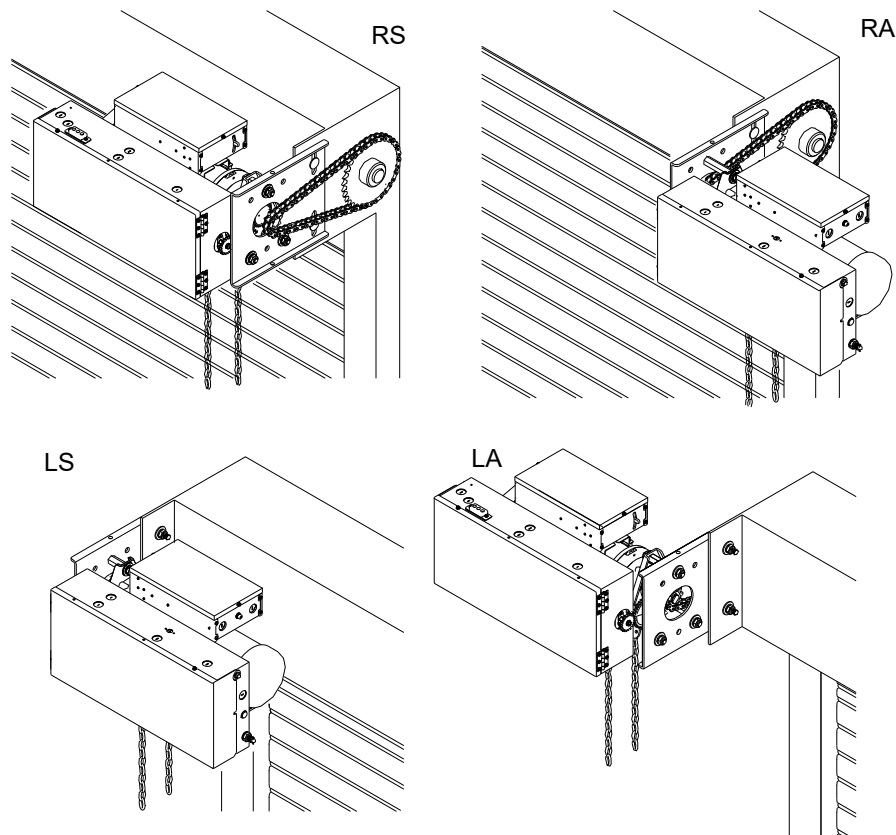

Consult factory for changes in mounting positions.

NOTE: Any change in mounting position may result in a change of operator rotation and consequently in a change of control functions. Consult factory for any changes. (LS and RA mounting positions are LH operators, RS and LA positions are RH operators)

Operators mounted in alternate positions (LA, RA) require the long mounting legs in lieu of the standard short mounting legs.

INSTALLATION POSITIONS (for 3/4 hp)

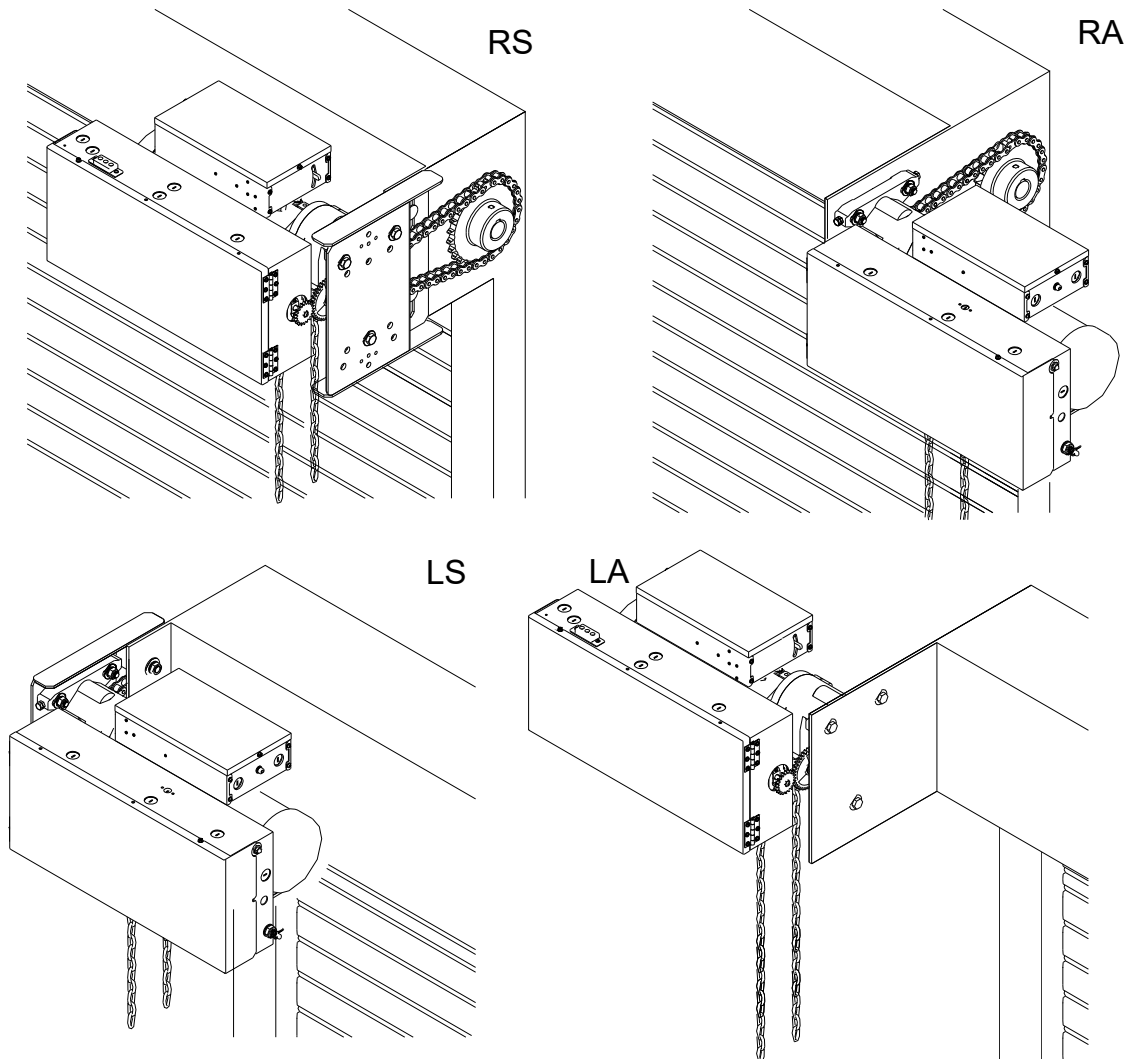

Installation positions for larger horsepower units are similar to as shown above.

Consult factory for changes in mounting positions.

NOTE: Any change in mounting position may result in a change of operator rotation and consequently in a change of control functions. Consult factory for any changes. (LS and RA mounting positions are LH operators, RS and LA positions are RH operators)

Operators mounted in alternate positions (LA, RA) require a straight mounting plate in lieu of the standard bent plate.

OPERATOR MOUNTING

1. Before the operator is installed, verify that the door is properly operating and balanced.
2. Make sure the layout of the mounting holes on the bracket is correct.
3. Bolt the operator mounting plate to the door bracket plate.
4. Attach and tighten the three mounting legs to the mounting plate (for 1/2 hp only).
5. Mount the operator to the three legs and tighten (for 1/2 hp only). For 3/4 hp, mount the operator base to the mounting plate.

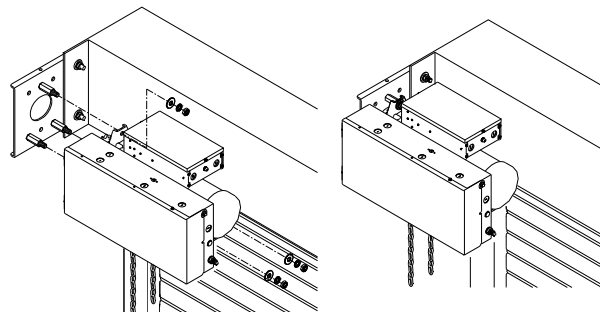
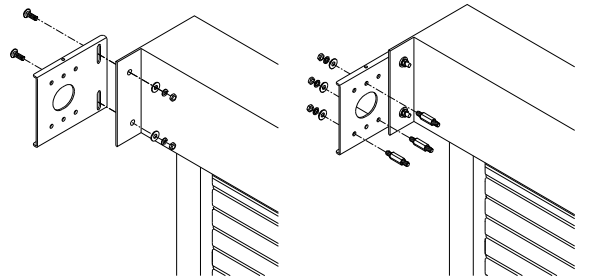

(Figure 1 for 1/2 hp)

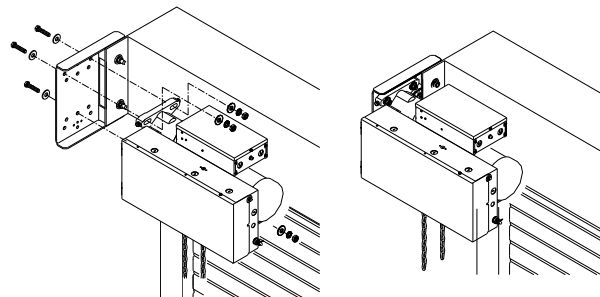
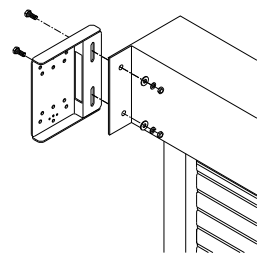

(Figure 2 for 3/4 hp)

6. When the operator assembly is attached to the door bracket, be sure the door driven sprocket is properly aligned with the operator drive sprocket before securing the driven sprocket to the shaft. (See Figure 1 for 1/2 hp; see Figure 2 for the 3/4 hp)
7. The bracket must provide adequate support for the operator. Prevent play between the operator and the door shaft. The operator must be securely attached with the drive shaft parallel to the door shaft. It may be necessary to field brace the operator/bracket.

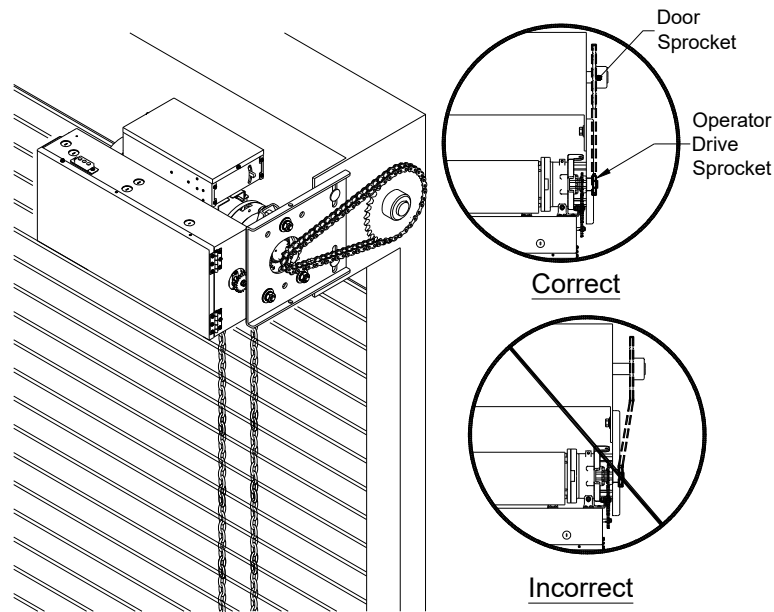

(Figure 1 for 1/2 hp)

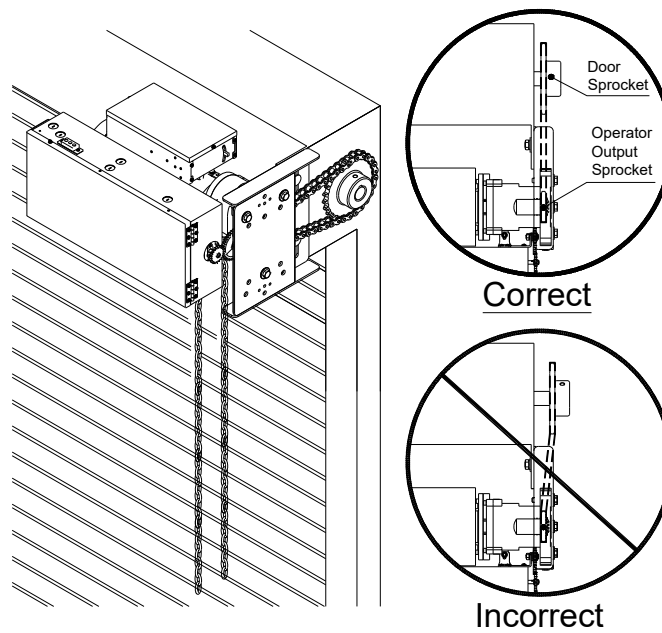

(Figure 2 for 3/4 hp)

DRIVE CHAIN ADJUSTMENT

NOTE: Use correct type, size and proper length of roller chain.

1. Adjust the drive chain by tilting or move the operator so that there is about 1/4" of slack when the chain is depressed.

Note: The set screws on the operator base may be used to make the adjustment. (See Figure 1- S1 location for 1/2 hp), (See Figure 2 - T1, T2 for 3/4 hp).

2. Once the drive chain has been tightened and the base leg screws have been set, then tighten the operator screws.

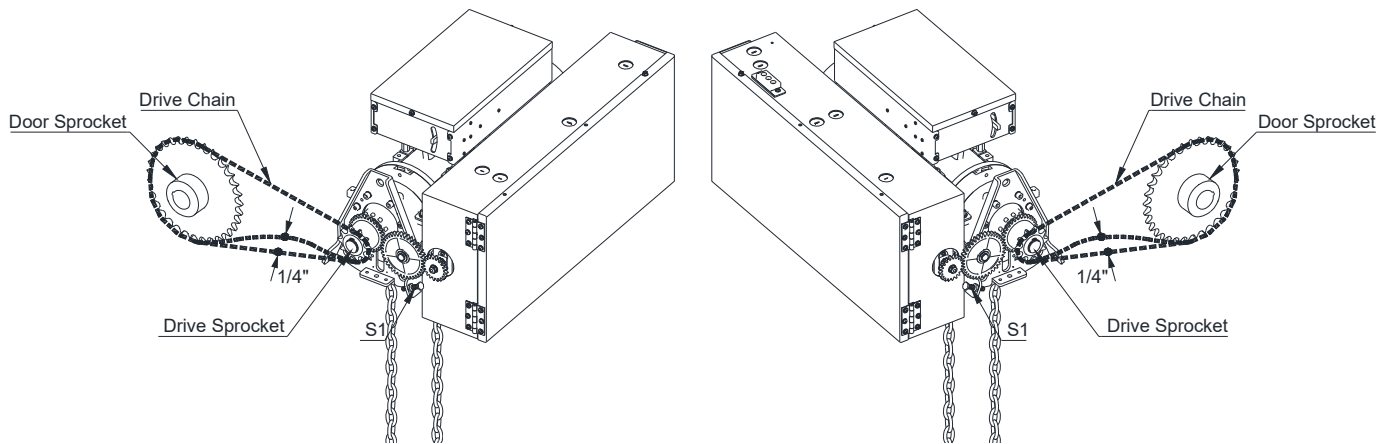

(Figure 1 for 1/2 hp)

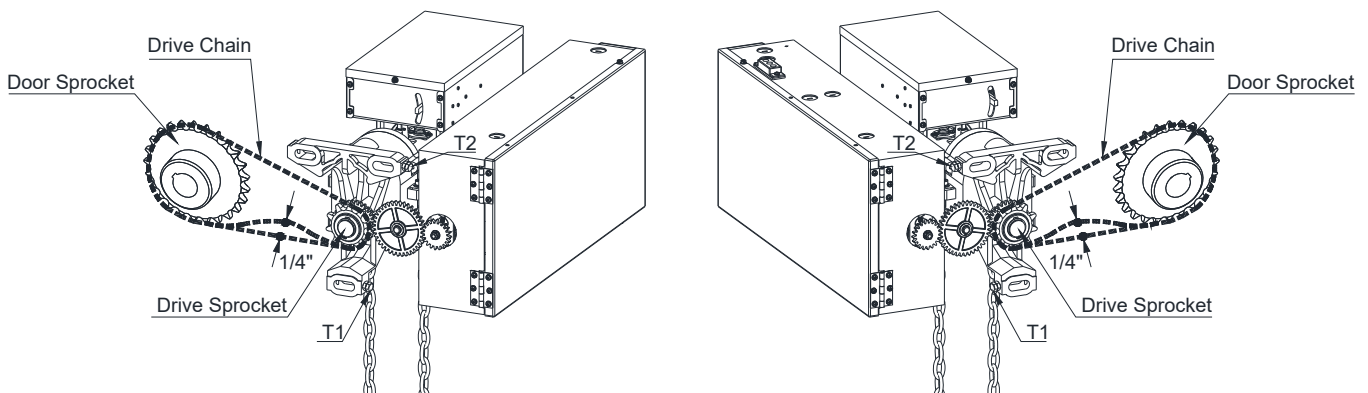

(Figure 2 for 3/4 hp)

HAND CHAIN ADJUSTMENT

If the hand chain is too long, cut and reconnect the chain with the different color connecting link provided. Completely close the connecting link so it is properly aligned.

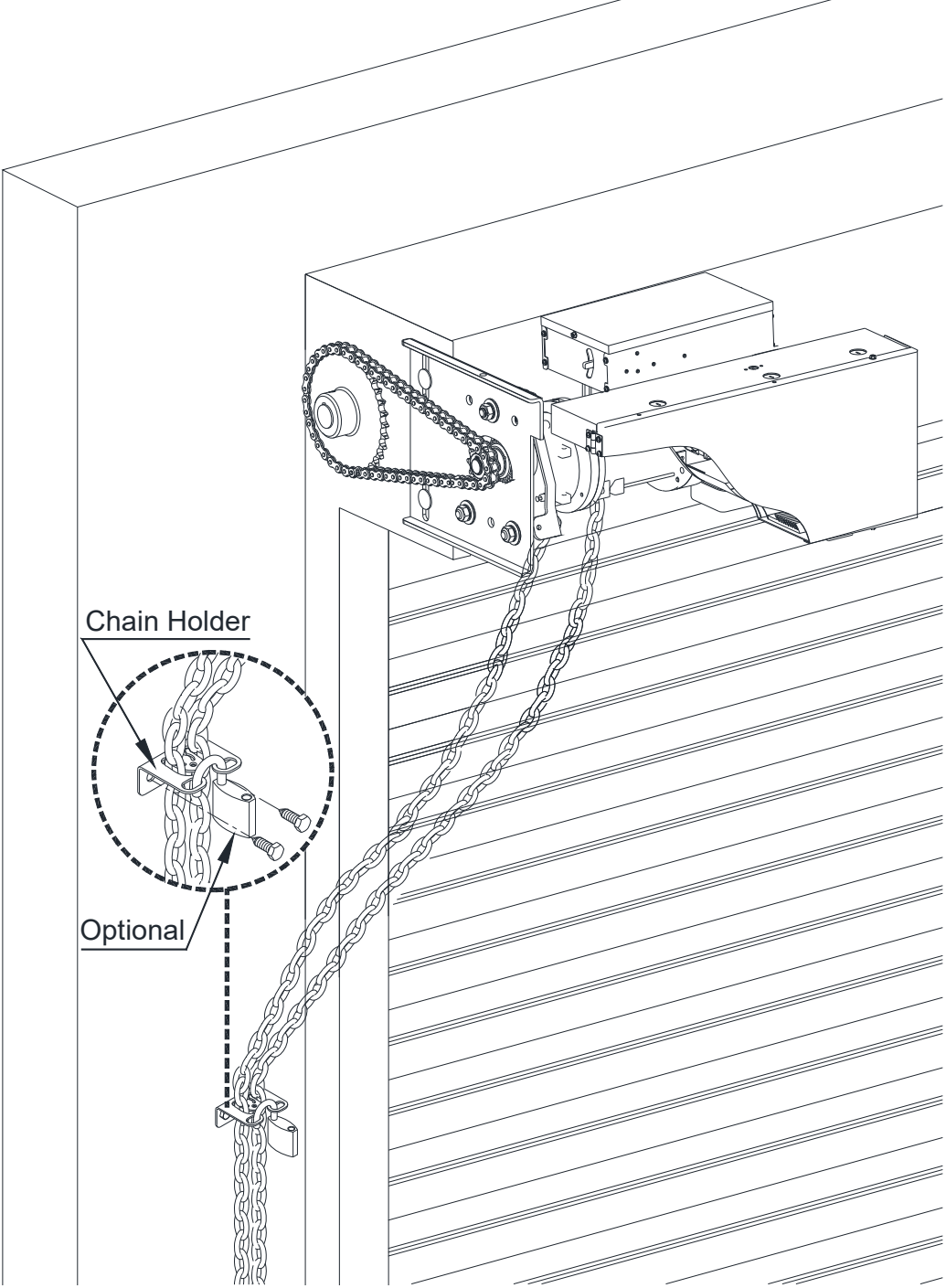

BRAKE RELEASE LEVER

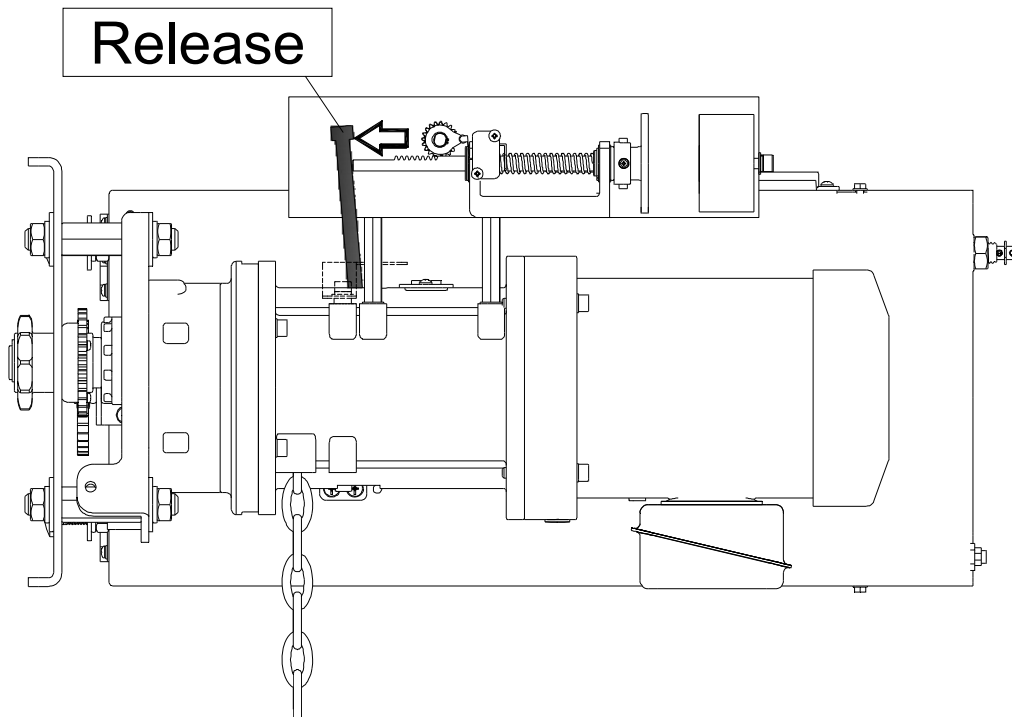

WARNING

Releasing the door operator brake, or loosening or removing any part of the door operator drive system, can cause the door to close and cause death or serious injury. **Do NOT release the brake, or loosen or remove any part of the door operator drive system**, unless the door is closed, or the curtain is secured in the open position to prevent uncoiling.

1. Pressing the brake release lever will release the motor brake and can cause the door to move uncontrolled.
2. Open-close-stop controls do not function while the brake release lever is pressed.
3. Fire doors using this operator have counterbalance springs that are adjusted during installation to allow the door to close automatically upon activation of the door operator release mechanism (brake release) without requiring a loss of spring tension.

LIMIT SWITCH ADJUSTMENT

Make sure the limit cams are positioned between the limit switch actuators before proceeding with adjustments.

1. Open the control panel cover.
2. Open or close the door part way to determine the direction of travel of the limit switch cams.
3. Open or close the door to the desired position.



WARNING Disconnect power before adjusting limit switch cams.

4. While pressing the spring-loaded plate (G), which holds the limit switch cams in place, adjust the limit switch cam (E or F) until the micro switch (C or D) clicking sound is heard.
5. If the limit switch cam cannot be rotated to its desired position, release the plate and move the door away from the desired position, then adjust the limit switch cam to its desired position. It may be necessary to repeat this step until the exact position has been reached.
6. Repeat step 3 and 4 for the opposite direction. Adjust close limit cams so that actuator is engaged as door fully closes to the floor.
7. "B" is usually the sensing edge cut-off switch and can be adjusted to accommodate sensing edge cut-off position. It is recommended that the switch position be adjusted as low as possible without interfering with close limit switch function.

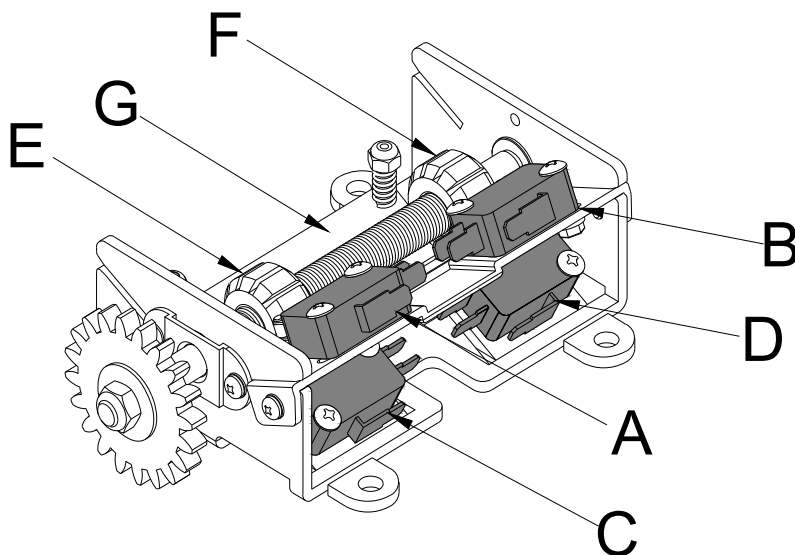

NOTE: "C" is usually the open limit switch and "D" is usually the close limit switch.

WIRING INSTRUCTIONS



Disconnect power at the fuse box before proceeding with any wiring.

WARNING

1. Do not install any wiring or attempt to run this operator without checking the wiring diagram located on the inside of the control box cover.
2. Do not turn on power until you have finished making all power and control wiring connections.
3. Do not run power and control wiring in the same conduit.
4. Any wire connected to the control panel must be protected by conduit or other means to ensure the safety and permanency of the wiring.
5. Use copper wire inside the control panel.
6. A separate fuse line of adequate capacity is needed for the operator.
7. The operator must be properly grounded. The ground screw, painted green, is located inside the control panel.
8. For an operator, system, or external device requiring field installed wiring between a Class 2 output of an operator and an external device, the type of wiring shall be R/C (AVLV2/8), AWM, min. 22 AWG, rated 60°C, with VW-1/FT2.



Failure to properly ground the operator could result in electric shock and death or serious injury.

WARNING



Unless the operator includes an internal lock sensing system, or external electrical interlocks are installed, remove or make all door locks inoperative, or secure locks in the unlocked position. Failure to disable the locks could result in damage to the door or operator.

WARNING

CONTROL WIRING



WARNING

If the door is not visible from the control station, or if any device other than a control station requiring constant pressure to close the door is used, a monitored sensing device must be installed on the door. Failure to do so could result in serious injury or death to person(s) trapped beneath the door.

1. Complete limit switch adjustments before making any sensing edge/non-contact device wiring connections to the operator.

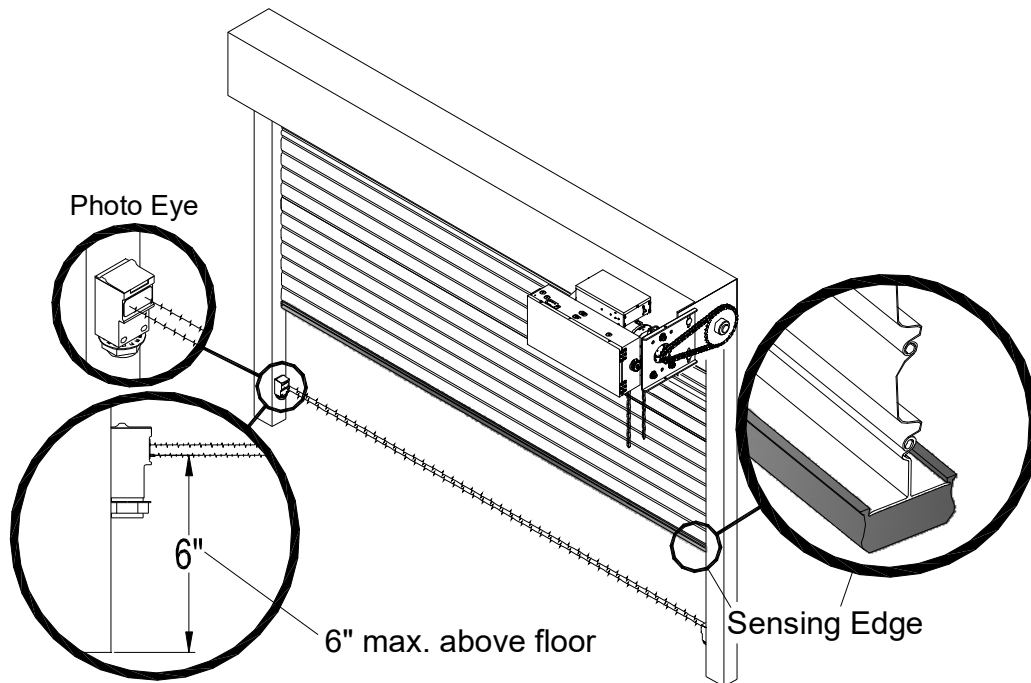

Entrapment Device Options:

Sensing Device Type	Device Manufacturer	Model
ELR 2-wire terminated sensing edge	ASO GmbH	25.30TTLL [A2530L-M], 15.25TTL [A1525-M], 30.70TTLa [A3070L-M], 15.25, 25.30, 25.45, 35.55, 35.85, 45.30, 30.70, 45, 65, 85 up to 115
	Miller Edge Inc. * Must have model number with Suffix T2.	ME110*, ME111*, ME120*, ME123*, ME112*, ME113*, ME116*, ME117*
		MT21*, MU21*, MT22*, MU22*, MC22*, MU33*, MC271*, CPT223*
		MEL-TXYY, MEL-RXYY
IR Emitter/receiver Reflective photo eyes and sensing edge	CEDES AG	Optical photo eyes and optical sensing edge, Models OPTOEYE [FOPE], OPTOEDGE, OSE, RAY-N Reflective Photo Eye, Ray/RT -2004 [FRPE]
	Mars International Inc	1266
	Miller Edge Inc.	IG2, MIRM, MLC-K36, MLC-K72
		RB-D-K10

Other approved devices may also be available – consult manufacturer for compatibility. [denotes Lawrence reference]

Note: Refer to sensing device manufacturer for specific installation and maintenance requirements.

2. If more than one monitored sensing device is to be used, each device must be connected to a separate ELR/IR sensing module to provide separate monitoring functions. Consult factory for a multiple device adapter.

WARNING

Do not install a timer to close the door unless some type of monitored entrapment protection device has been installed. Failure to do so may result in death or serious injury to person(s) trapped beneath the door.

3. If a timer to close (reclose timer) is to be used, a compatible reclose timer module is required that will not interfere with the monitoring of sensing device functions. Consult factory for the correct reclose timer module,

WARNING

Disconnect power at the fuse box before proceeding with any wiring.

4. Locate the control station at a minimum height of 5 feet above the floor, and where the user can clearly see the operation of the door. Mount the enclosed placard adjacent to or near the door.



WARNING

Controls shall be located far enough away from the door, or positioned such that the user is prevented from coming in contact with the door, while operating the controls.

5. Do not run control wiring in the same conduit as power wiring.
6. Any wires connected to the control panel must be protected by conduit or other means to ensure the safety and permanency of the wiring.

WARNING

Do not install radio controls (receiver/transmitter) to operate the door unless some type of monitored entrapment protection device has been installed. Failure to do so may result in death or serious injury to person(s) trapped beneath the door.

WARNING

Changing from left hand to right hand or vice versa could result in change of control wiring. Consult factory for details.

7. After installation, be sure that the operator, controls, and sensing edge or other entrapment protection devices have been tested and function properly.

A. Control Function:

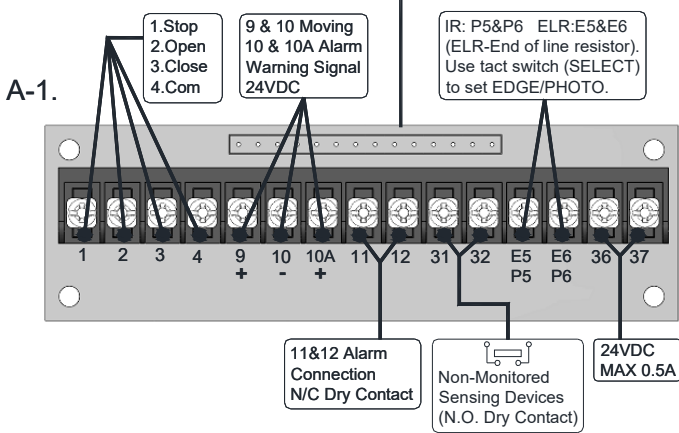
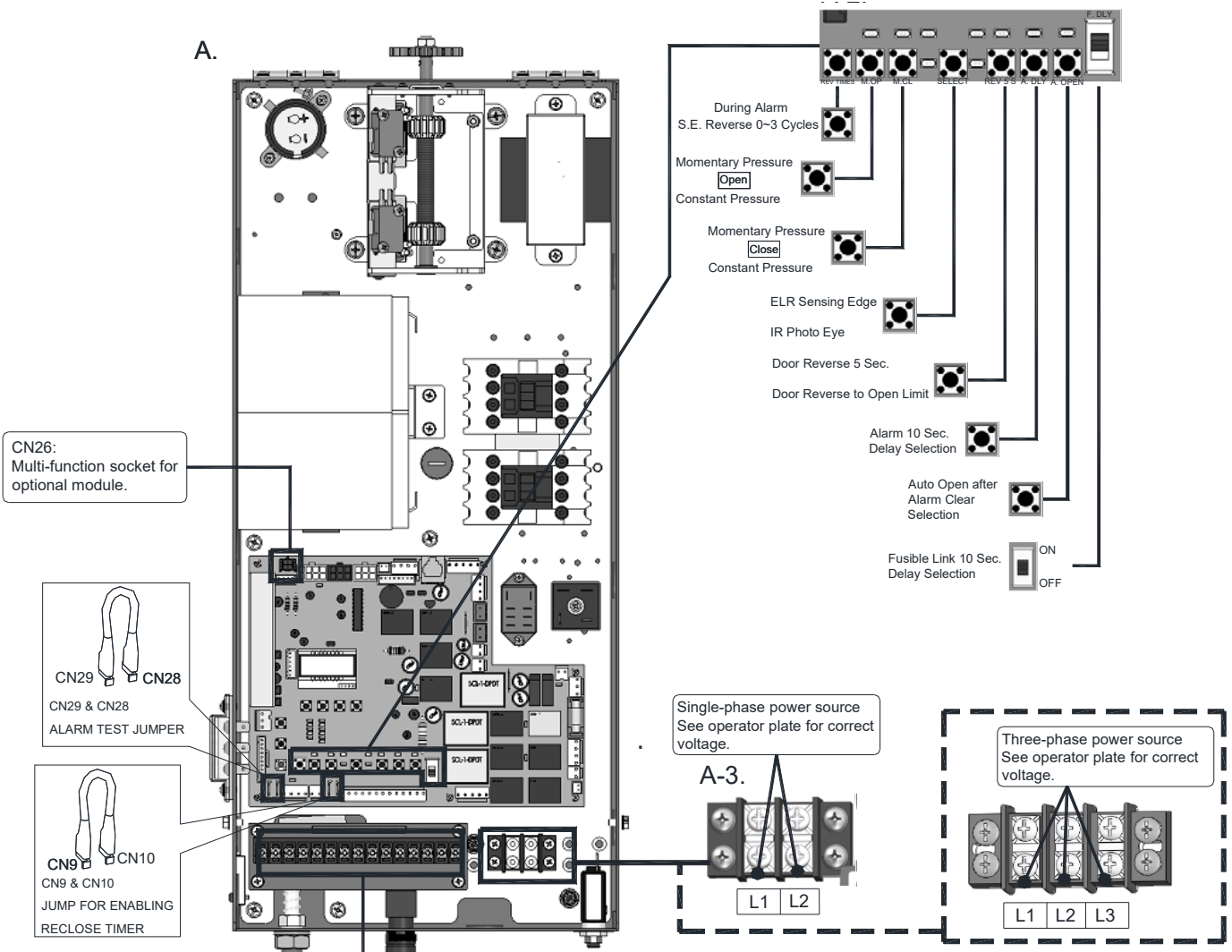

Notes:

- If momentary contact close is desired, an entrapment protection device must be installed and tact switch (M.CL) to ON (LED 12 lits).
- Alarm power close when entrapment device(s) is connected.
- Alarm gravity close when entrapment device(s) is not connected.
- During alarm power closing, stop button is functional for 10 seconds max. per pressing and entrapment device(s) is functional.
- Both AC and DC powers failed, door gravity close and the chain hoist is disabled.
- During AC power presents and alarm gravity closing, safety wiring is functional, including stop button and entrapment device(s).
- During AC/DC power present and alarm gravity closing, the brake will be engaged for 10 seconds when the door reaches close limit.
- Brake engaged, when door reached close limit during alarm and AC power failed, till battery voltage drops below 19VDC.
- Standard 10-second delay during power failure.
- Standard one-second delay on reverse.
- Per NFPA 80, during alarm, if equipped with sensing device, door will stop on an obstruction after attempting to close the number of times selected on the (REV TIMES) tact switch.

B. Auxiliary Function:

B-2. Radio control

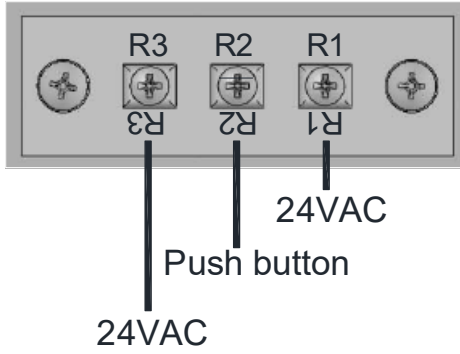

B-1.

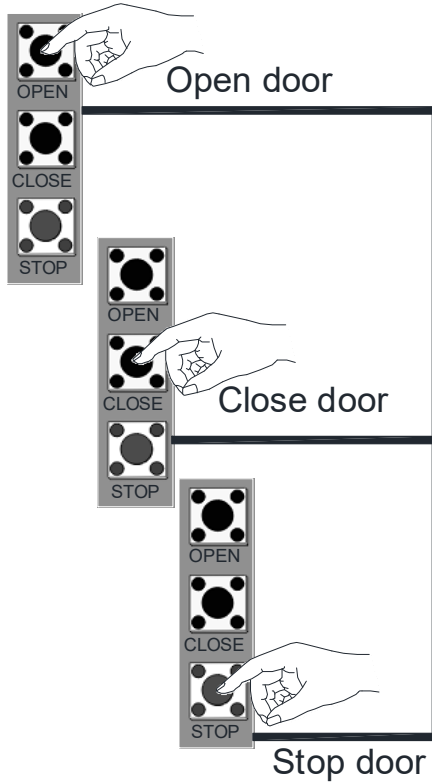

B.

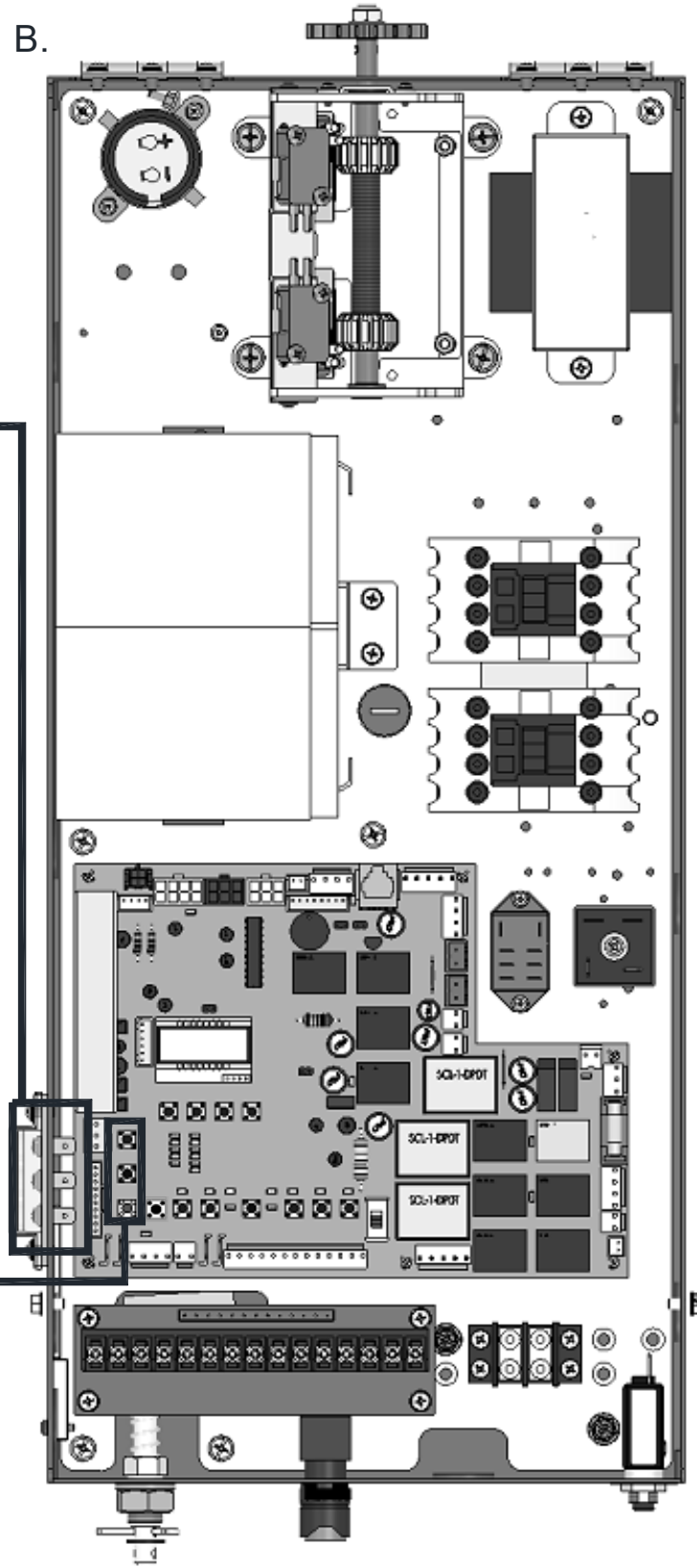

C. Timer Instruction:

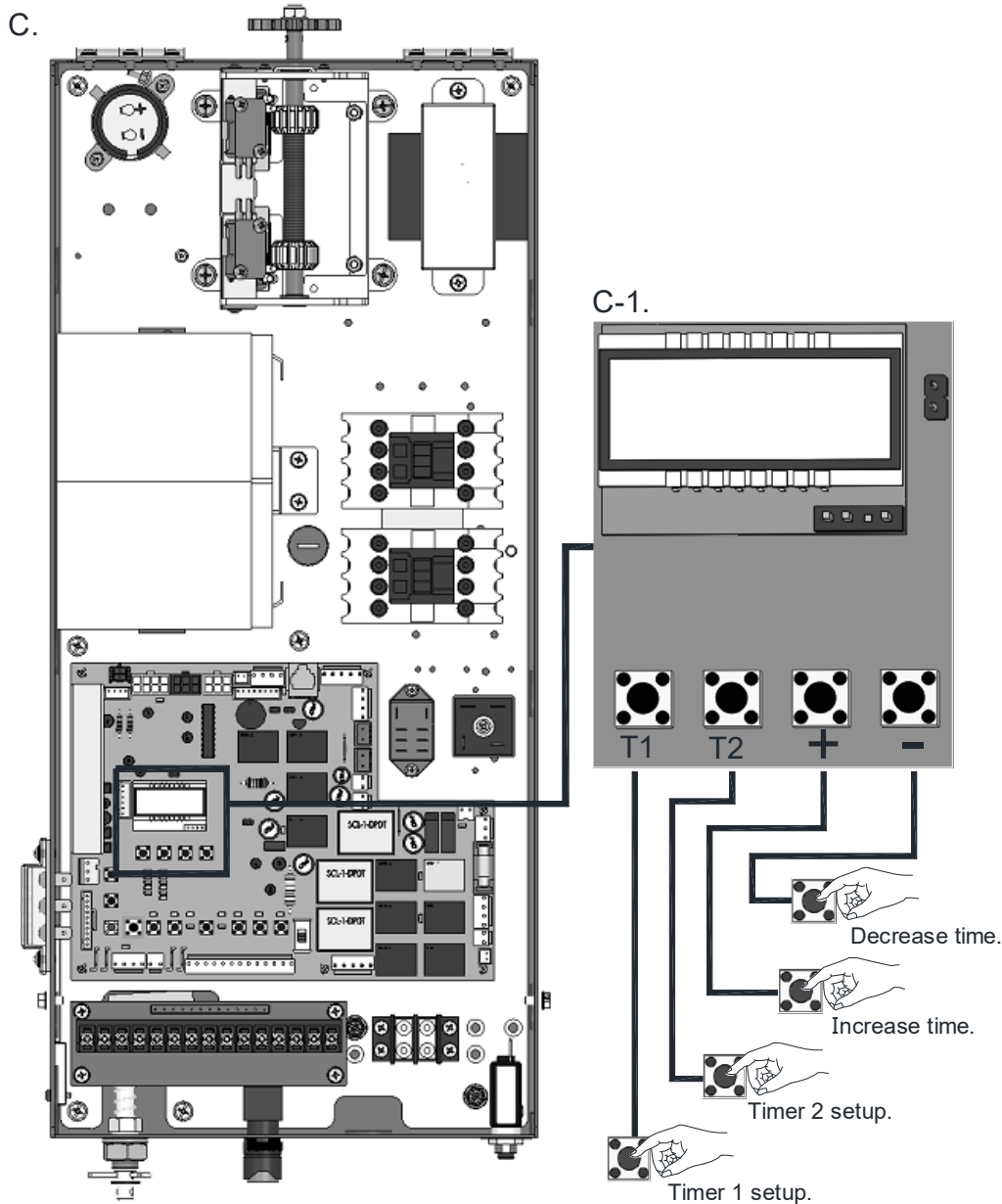





(1) Timer 1 – Mid-open timer: Timer starts counting when door leaves close limit. Door stops after opening for set time. Pressing open again at mid-open position will cause door to open limit.

Timer 2 – Close timer: Timer is active when door stops and is not at close limit.



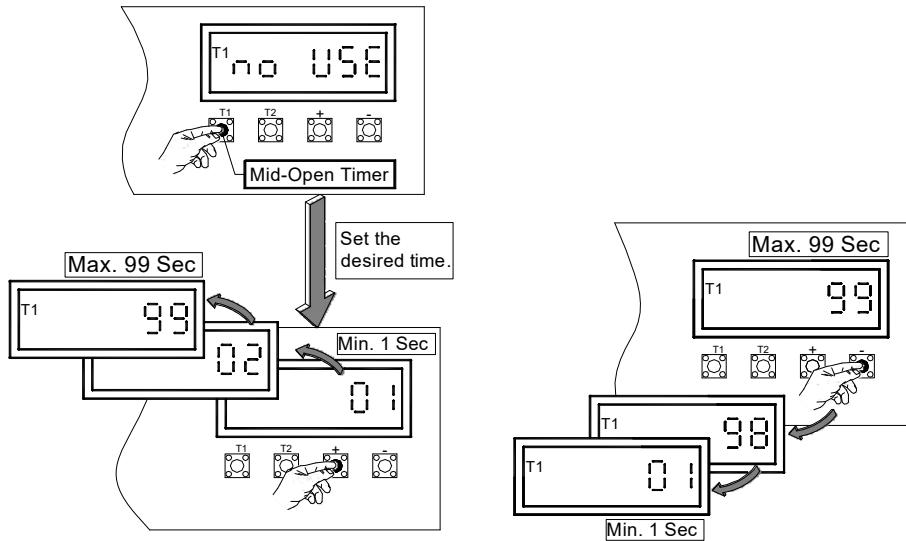

(2) Standard Mode: Cycle counter

(3) To Set Timer 1 (Mid-open Timer):

- Press  and hold for 5 seconds. Display will flash.
- Use  or  to increase or to decrease time.
- Press  to save setting. Without pressing, no adjustment is saved.



(4) To Set Timer 2 (Reclose Timer):

- Press  and hold for 5 seconds. Display will flash.
- Use  or  to increase or to decrease time.
- Press  to save setting. Without pressing, no adjustment is saved.

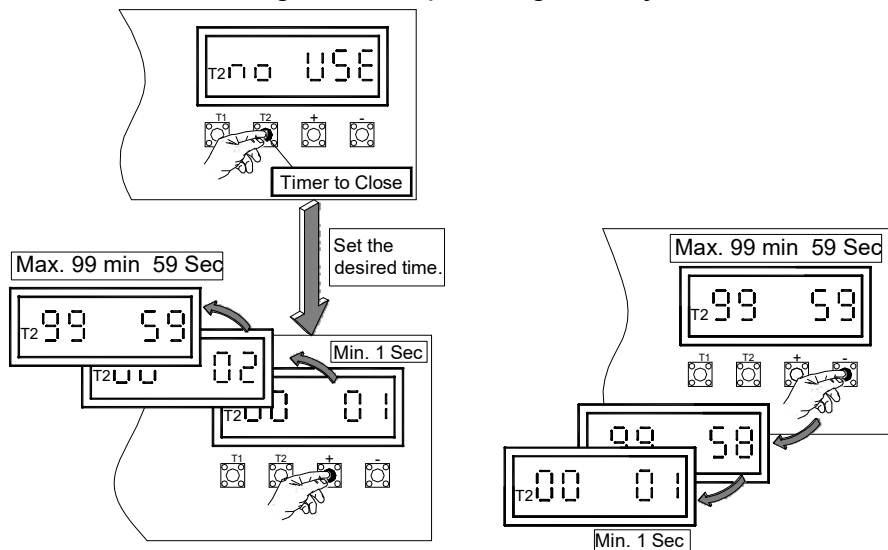

D. LCD Display Instruction:

Display	Status	Display	Status
	T1 setting		Door closing
	T2 setting		Door opening
	T1 or T2 setting completed		Alarm condition
	Limit switches don't response or respond both limits reached in standby or running period.		Two host controllers are setting at the same time.
	Connection interruption		Limit switch on client controller is abnormal.

E. Light Indication:

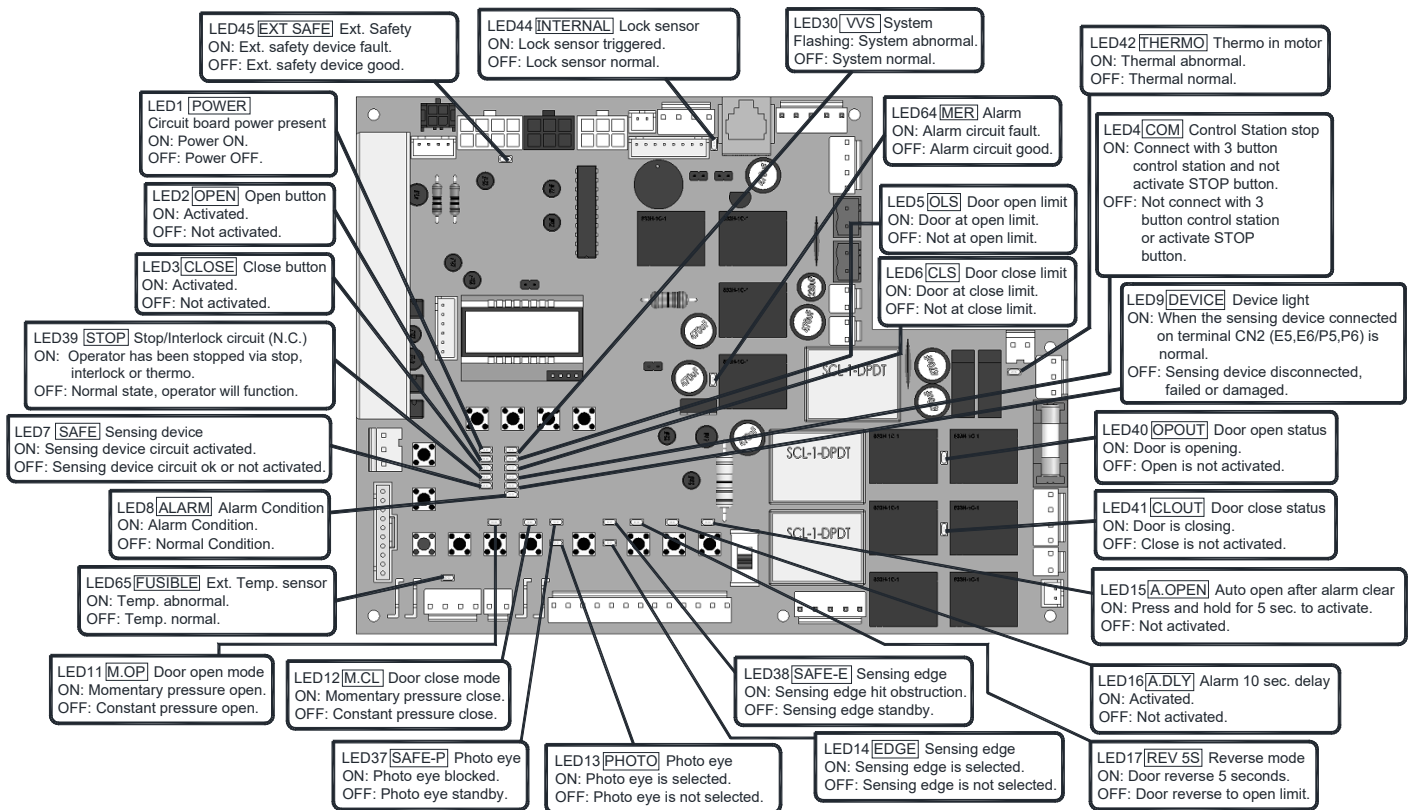

F. Sound Warnings:

Item	Description	Sound
1	Release device lever dis-armed	B_____
2	Alarm warning signal	B____, B____, B____, B____, ...
3	Terminal CN2 (1,4) not connected	B.B.B.B., B.B.B.B., B.B.B.B., B.B.B.B., ...
4	AC power abnormal	B____ B.B., B____ B.B., B____ B.B.,
5	Battery voltage below 22V	B. B. B. B. B. B. B. B. B. B.
6	Battery failed	B____ B.B.B., B____ B.B.B., B____ B.B.B., ..
7	Charge failed	B.B., B.B., B.B., B.B., B.B., B.B., B.B., ...

BATTERY SPECIFICATION & CONNECTION

Specification:

Type	Battery Rating	Battery Expected Standby Operating Time(s)
Sealed Lead Acid Rechargeable Battery	Two (2) 12VDC, Max. 5AH	8 Hours (Fully charged status)



WARNING

This unit has an internal battery that may still be charged and holding the door from releasing even in the event of a loss of line power.

Connection:

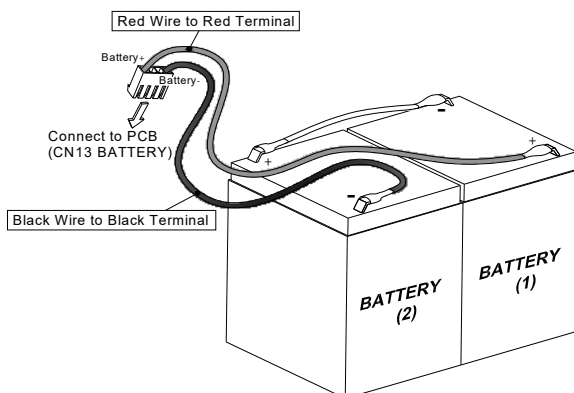

Charging Voltage:	27.6VDC
Charging Current:	Max. 1.0A

- Low battery voltage warning output signal is provided when battery voltage drops below 22VDC.
- In the condition that the battery voltage is lower than 20VDC, the DC power circuit will be shut off.
- After replacing a new battery, the green battery button needs to be reset so that the DC power circuit can be resumed.
- When AC power resumed, the DC power circuit is automatically restored.

FSH 115V 1 PHASE 50/60HZ LH (EP BOARD)
(FOR FSH-51EP, 71EP, 151EP)

EBH 104EP L

- MAINBOARD PCB :
- EXTERNAL MODULE-MULTI FUNCTION SOCKET FOR OPTIONAL MODULE
 - SENSING DEVICE-SENSING MODULE CONNECTOR
 - SEC-CLOSE CONTROL CONNECTOR
 - SEC-OPEN CONTROL CONNECTOR
 - POWER INDICATOR-SOCKET RJ11 FOR POWER INDICATOR CONNECTION
 - BATTERY SWITCH - BATTERY SWITCH CONNECTION
 - LOWBATT-LDW BATTERY STATUS DRY CONTACT OUTPUT SIGNAL
 - 1019-EXTERNAL POWER INPUT 24VAC/DC
 - 12K-24VDC OUTPUT FOR T2000 MAGNETIC POWER.
 - AR-E-SIGNALS TO RELEASING DEVICE
 - TIMER POWER-JUMP FOR ENABLING RECLOSE TIMER
 - TH2-TEMPERATURE SENSOR
 - ALARM TEST-ALARM TEST JUMPER
 - BZ1-SOUND PATTERN REFER TO 'F. SOUND WARNINGS' IN THE MANUAL.
 - F. DLY-FUSIBLE LINK DELAY 10 SEC.
 - A. OPEN-AUTO OPEN AFTER ALARM CLEAR
(PRESS AND HOLD FOR 5 SEC. TO ACTIVATE)
 - A. DLY-ALARM DELAY 10 SEC.
 - REV 5S-REVERSE TO OPEN LIMIT OR REVERSE 5 SEC.
 - SELECT-EDGE/PHOTO EYE SENSING DEVICE SELECTION
 - M. CL-MOMENTARY/CONSTANT PRESSURE CLOSE
 - M. CP-MOMENTARY/CONSTANT PRESSURE OPEN
 - REV TIMES-HIT & REVERSE CYCLES
 - T1 & T2-SEE INSTRUCTION MANUAL FOR DETAIL
 - JPA-DD NOT REMOVE, INTERNAL USE
 - JP2-OPEN AND CLOSE WARNING SIGNAL (JUMPED).
REMOVE JUMPER FOR CLOSE WARNING SIGNAL ONLY.
 - JP4-RESERVED, INTERNAL USE.
 - JP5-DD NOT REMOVE, INTERNAL USE
 - JP10-BRANKE ENGAGE / DIS-ENGAGE AT CLOSE LIMIT POSITION
 - JP11-RESERVED, INTERNAL USE.

- TERMINAL PCB - CN2 :
- CONTROL STATION-STOP
 - CONTROL STATION-OPEN
 - CONTROL STATION-CLOSE
 - CONTROL STATION-COMM
- 9X10-MOVING WARNING SIGNAL 24VDC
10X10-ALARM WARNING SIGNAL 24VDC
11X12-ALARM CONNECTION N/C DRY CONTACT
31X32 NON-MONITORED SENSING DEVICES
(N/D DRY CONTACT)
E5X6/P58P6-EDGE/PHOTO EYES SENSING
DEVICE CONNECTION
36637 24VDC-POWER, MAX. 0.5A

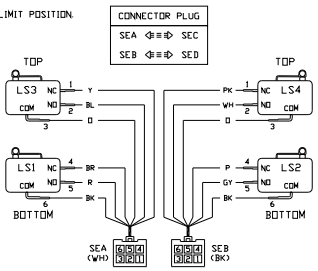

- NOTES :
- SEA-LS1 & LS3 MICROSWITCH CONNECTOR
 - SEB-LS2 & LS4 MICROSWITCH CONNECTOR

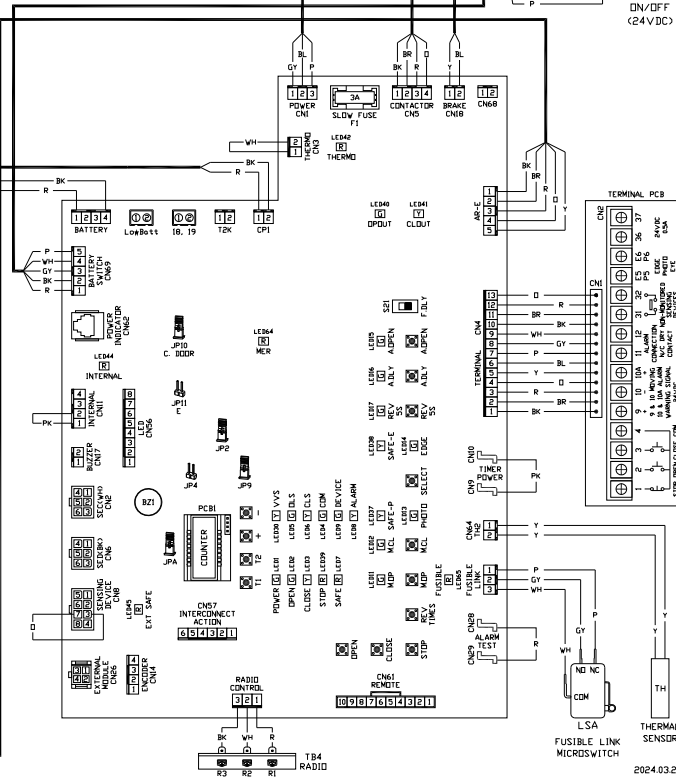
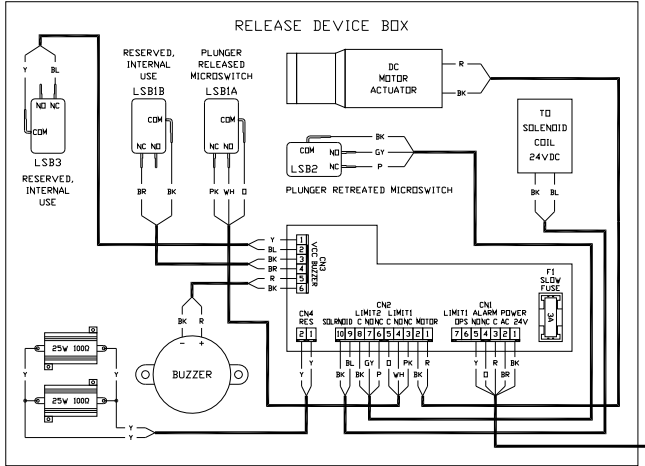
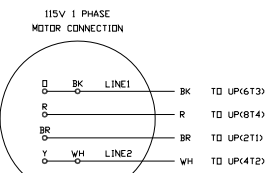
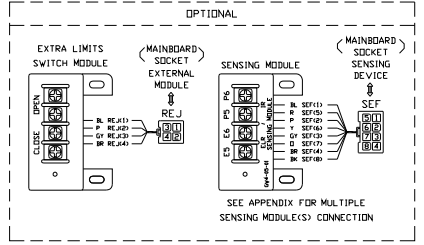
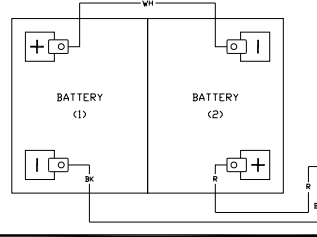
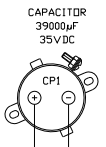
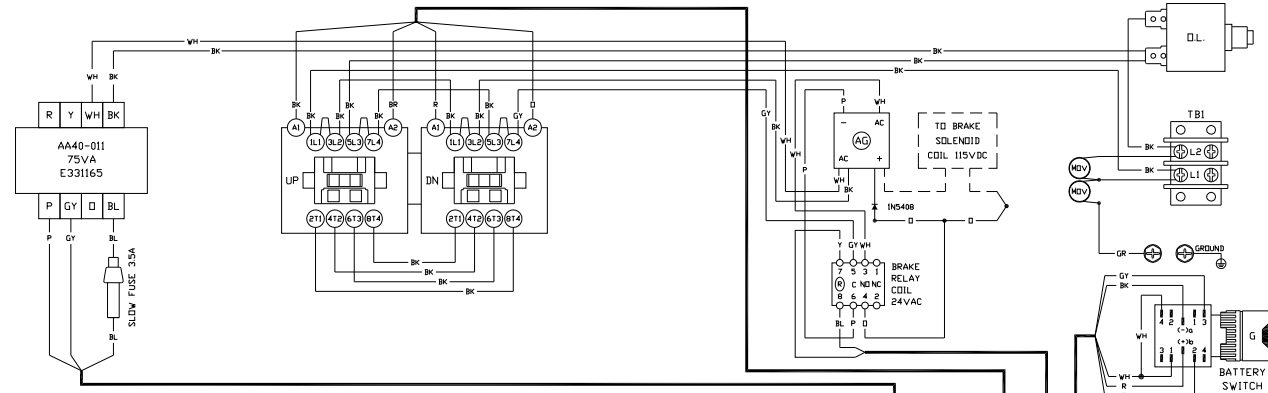

FSH 115V 1 PHASE 50/60HZ RH (EP BOARD)
(FOR FSH-51EP, 71EP, 151EP)

EBH 104EP R

- MAINBOARD PCB -
- EXTERNAL MODULE-MULTI FUNCTION SOCKET FOR OPTIONAL MODULE
 - SENSING DEVICE-SENSING MODULE CONNECTOR
 - SEC-CLOSE CONTROL CONNECTOR
 - SEC-OPEN CONTROL CONNECTOR
 - POWER INDICATOR-SOCKET RJ11 FOR POWER INDICATOR CONNECTION
 - BATTERY SWITCH - BATTERY SWITCH CONNECTION
 - LDWBATT-LOW BATTERY STATUS DRY CONTACT OUTPUT SIGNAL
 - 18.19-EXTERNAL POWER INPUT 24VAC/DC
 - T2K-24VDC OUTPUT FOR T2000 MAGNETIC POWER
 - AR-E-SIGNALS TO RELEASING DEVICE
 - TIMER POWER-JUMP FOR ENABLING RECLOSE TIMER
 - TH2-TEMPERATURE SENSOR
 - ALARM TEST-ALARM TEST JUMPER
 - BZ1-SOUND PATTERN REFER TO "F. SOUND WARNINGS" IN THE MANUAL.
 - F. DLY-FUSIBLE LINK DELAY 10 SEC.
 - A. OPEN-AUTO OPEN AFTER ALARM CLEAR (PRESS AND HOLD FOR 5 SEC. TO ACTIVATE)
 - A. DLY-ALARM DELAY 10 SEC.
 - REV 9S-REVERSE TO OPEN LIMIT OR REVERSE 5 SEC.
 - SELECT-EDGE/PHOTO EYE SENSING DEVICE SELECTION
 - M. CL-MOMENTARY/CONSTANT PRESSURE CLOSE
 - M. OP-MOMENTARY/CONSTANT PRESSURE OPEN
 - REV TIMES-HIT & REVERSE CYCLES
 - T1 & T2-SEE INSTRUCTION MANUAL FOR DETAIL
 - JP4-BD NOT REMOVE, INTERNAL USE
 - JP2-OPEN AND CLOSE WARNING SIGNAL (JUMPED) REMOVE JUMPER FOR CLOSE WARNING SIGNAL ONLY.
 - JP4-RESERVED, INTERNAL USE.
 - JP9-BD NOT REMOVE, INTERNAL USE
 - JP10-BRAKE ENGAGE / DIS-ENGAGE AT CLOSE LIMIT POSITION
 - JP11-RESERVED, INTERNAL USE.

- TERMINAL PCB - CNI -
- CONTROL STATION-STDP
 - CONTROL STATION-OPEN
 - CONTROL STATION-CLOSE
 - CONTROL STATION-COMDN
 - MOVING WARNING SIGNAL 24VDC
 - 10&10A-ALARM WARNING SIGNAL 24VDC
 - 11&12-ALARM CONNECTION N/C DRY CONTACT
 - 31&32 NON-MONITORED SENSING DEVICES (N/D DRY CONTACT)
- ES8E6/P5&P6-EDGE/PHOTO EYES SENSING DEVICE CONNECTION
3&6/37 24VDC-POWER, MAX. 0.5A

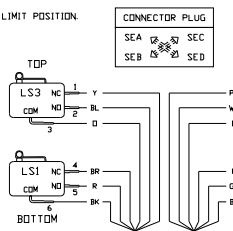

- NOTES :
- SEA-LS1 & LS3 MICROSWITCH CONNECTOR
 - SEB-LS2 & LS4 MICROSWITCH CONNECTOR

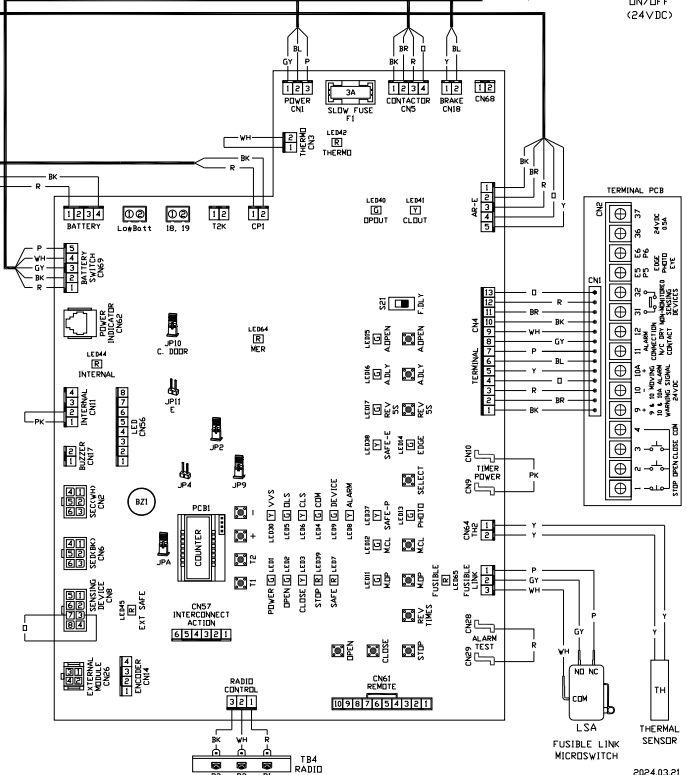
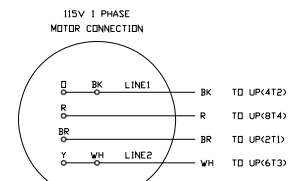
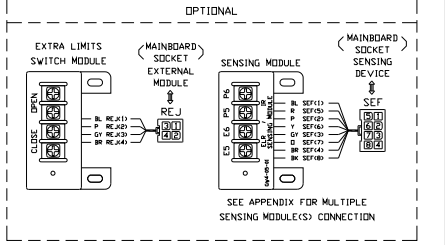
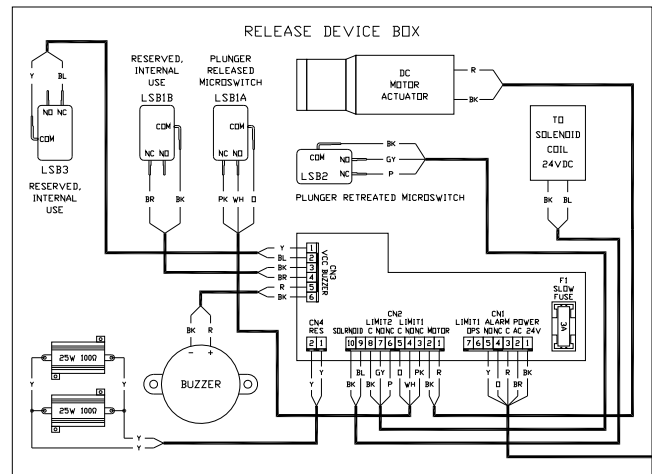
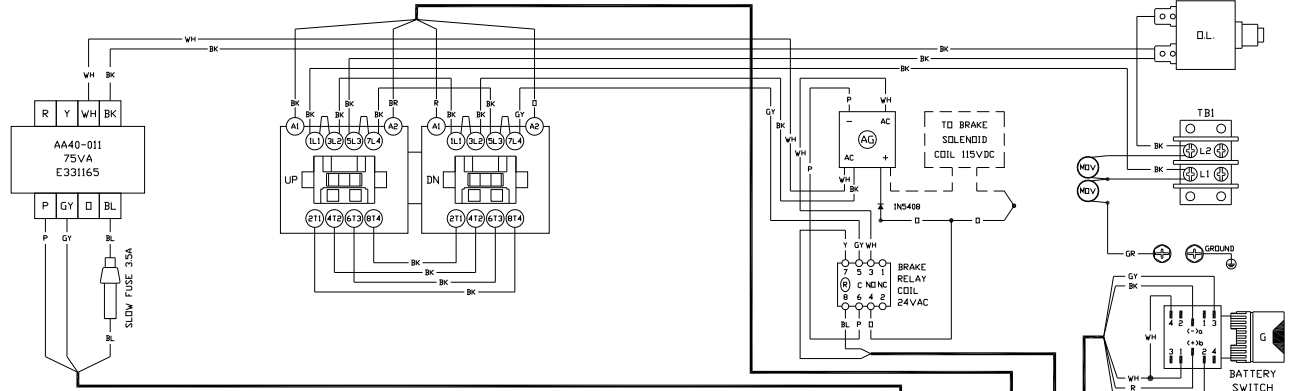

FSH 230V 1 PHASE 50/60HZ LH (EP BOARD)
 (60HZ FOR FSH-52EP, 72EP, 152EP)
 (50HZ FOR FSH-55EP, 75EP, 155EP)

EBH 204EP L

- MAINBOARD PCB :
- EXTERNAL MODULE-MULTI FUNCTION SOCKET FOR OPTIONAL MODULE
 - SENSING DEVICE-SENSING MODULE CONNECTOR
 - SEC-CLOSE CONTROL CONNECTOR
 - SEC-OPEN CONTROL CONNECTOR
 - POWER INDICATOR-SOCKET R-111 FOR POWER INDICATOR CONNECTION
 - BATTERY SWITCH - BATTERY SWITCH CONNECTION
 - LDWBATT-LDW BATTERY STATUS DRY CONTACT OUTPUT SIGNAL
 - 18J19-EXTERNAL POWER INPUT 24VAC/DC
 - T2K-24VDC OUTPUT FOR T2000 MAGNETIC POWER
 - AR-E-SIGNALS TO RELEASING DEVICE
 - TIMER POWER-JUMP FOR ENABLING RECLOSE TIMER
 - TH2-TEMPERATURE SENSOR
 - ALARM TEST-ALARM TEST JUMPER
 - BZ1-SOUND PATTERN REFER TO 'F. SOUND WARNINGS' IN THE MANUAL
 - F. DL1-FUSIBLE LINK DELAY 10 SEC.
 - A. OPEN-AUTO OPEN AFTER ALARM CLEAR
 - (PRESS AND HOLD FOR 5 SEC. TO ACTIVATED)
 - A. DLY-ALARM DELAY 10 SEC.
 - REV 5S-REVERSE TO OPEN LIMIT OR REVERSE 5 SEC.
 - SELECT-EDGE/PHOTO EYE SENSING DEVICE SELECTION
 - M. CL-MOMENTARY/CONSTANT PRESSURE CLOSE
 - M. DP-MOMENTARY/CONSTANT PRESSURE OPEN
 - REV TIMES-HIT & REVERSE CYCLES
 - T1 & T2-SEE INSTRUCTION MANUAL FOR DETAIL
 - JP4-DO NOT REMOVE, INTERNAL USE
 - JP2-OPEN AND CLOSE WARNING SIGNAL (JUMPED)
 - REMOVE JUMPER FOR CLOSE WARNING SIGNAL ONLY.
 - JP4-RESERVED, INTERNAL USE.
 - JP9-DO NOT REMOVE, INTERNAL USE
 - JP10-BRAKE ENGAGE / DIS-ENGAGE AT CLOSE LIMIT POSITION
 - JP11-RESERVED, INTERNAL USE.

- TERMINAL PCB - CN2 :
- CONTROL STAT1DN-STOP
 - CONTROL STAT1DN-OPEN
 - CONTROL STAT1DN-CLOSE
 - CONTROL STAT1DN-COMMON
 - MOVING WARNING SIGNAL 24VDC
 - 10610A-ALARM WARNING SIGNAL 24VDC
 - 11612-ALARM CONNECTION N/C DRY CONTACT
 - 31632 NON-MONITORED SENSING DEVICES (N/O DRY CONTACT)
 - ES86E/PS8P6-EDGE/PHOTO EYES SENSING DEVICE CONNECTION
 - 368.27 24VDC-POWER, MAX. 0.5A

- NOTES :
- SEA-LS1 & LS3 MICROSWITCH CONNECTOR
 - SEB-LS2 & LS4 MICROSWITCH CONNECTOR

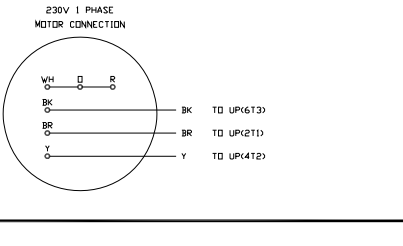
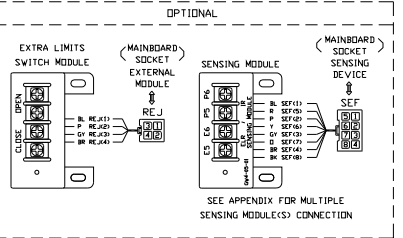
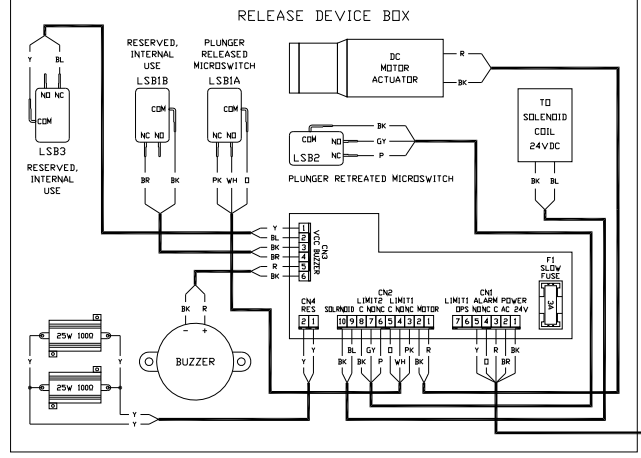
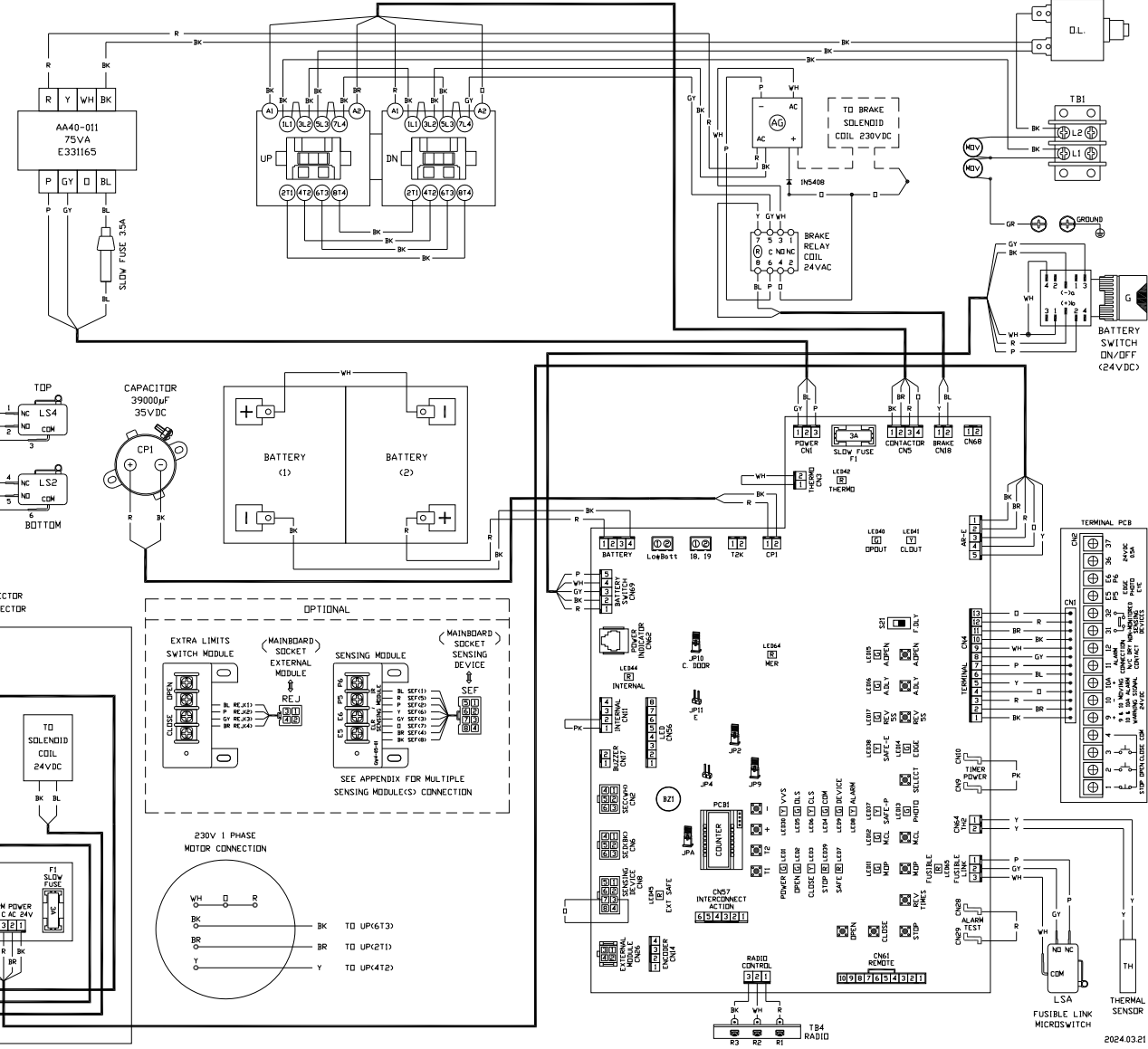

FSH 230V 1 PHASE 50/60HZ RH (EP BOARD)
 (60HZ FOR FSH-52EP, 72EP, 152EP)
 (50HZ FOR FSH-55EP, 75EP, 155EP)

EBH 204EP R

- MAINBOARD PCB :
- EXTERNAL MODULE-MULTI FUNCTION SOCKET FOR OPTIONAL MODULE
 - SENSING DEVICE-SENSING MODULE CONNECTOR
 - SEC-CLOSE CONTROL CONNECTOR
 - SEC-OPEN CONTROL CONNECTOR
 - POWER INDICATOR-SOCKET RJ11 FOR POWER INDICATOR CONNECTION
 - BATTERY SWITCH - BATTERY SWITCH CONNECTION
 - LOWBATT-LOW BATTERY STATUS DRY CONTACT OUTPUT SIGNAL
 - 1819-EXTERNAL POWER INPUT 24VAC/DC
 - 12K-24VDC OUTPUT FOR 12000 MAGNETIC POWER
 - AR-E-SIGNALS TO RELEASING DEVICE
 - TIMER POWER-JUMP FOR ENABLING RECLOSE TIMER
 - TH2-TEMPERATURE SENSOR
 - ALARM TEST-ALARM TEST JUMPER
 - BZ1-SOUND PATTERN REFER TO 'F. SOUND WARNINGS' IN THE MANUAL.
 - F. DLY-FUSIBLE LINK DELAY 10 SEC.
 - A. OPEN-AUTO OPEN AFTER ALARM CLEAR (PRESS AND HOLD FOR 5 SEC TO ACTIVATE)
 - A. DLY-ALARM RELAY 10 SEC.
 - REV 55-REVERSE TO OPEN LIMIT OR REVERSE 5 SEC
 - SELECT-EDGE/PHOTO EYE SENSING DEVICE SELECTION
 - M. CL-MOMENTARY/CONSTANT PRESSURE CLOSE
 - M. DP-MOMENTARY/CONSTANT PRESSURE OPEN
 - REV TIMES-HIT & REVERSE CYCLES
 - T1 & T2-SEC INSTRUCTION MANUAL FOR DETAIL
 - JPA-DD NOT REMOVE, INTERNAL USE
 - JP2-OPEN AND CLOSE WARNING SIGNAL (JUMPED). REMOVE JUMPER FOR CLOSE WARNING SIGNAL ONLY.
 - JP4-RESERVED, INTERNAL USE
 - JP9-DD NOT REMOVE, INTERNAL USE
 - JP10-BRAKE ENGAGE / DIS-ENGAGE AT CLOSE LIMIT POSITION
 - JP11-RESERVED, INTERNAL USE.

- TERMINAL PCB - CN2 :
- CONTROL STATION-STOP
 - CONTROL STATION-OPEN
 - CONTROL STATION-CLOSE
 - CONTROL STATION-COMMON
 - MOVING WARNING SIGNAL 24VDC
 - 1810A-ALARM WARNING SIGNAL 24VDC
 - 11812-ALARM CONNECTION N/C DRY CONTACT
 - 13832-NDN-MONITORED SENSING DEVICES (N/D DRY CONTACT)
 - E58E6/P58P6-EDGE/PHOTO EYES SENSING DEVICE CONNECTION
 - 36437 24VDC-POWER, MAX. 0.5A

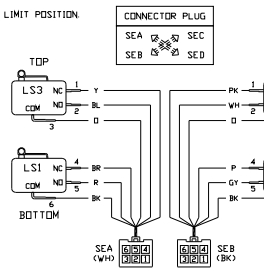

- NOTES :
- SEA-LS1 & LS3 MICROSWITCH CONNECTOR
 - SEB-LS2 & LS4 MICROSWITCH CONNECTOR

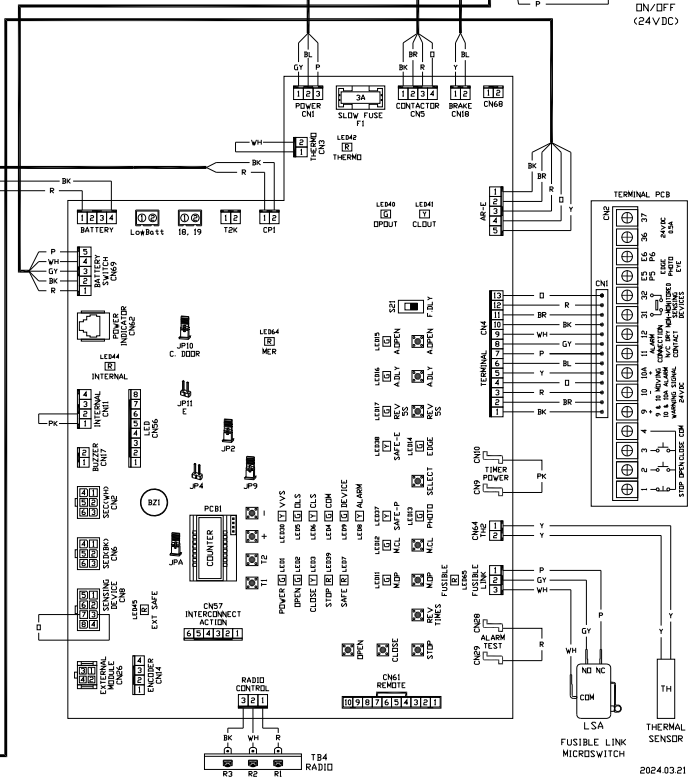
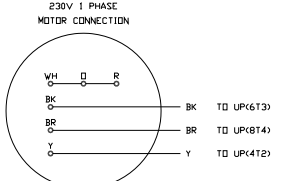
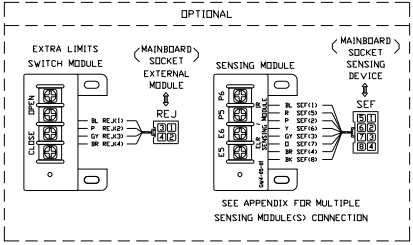
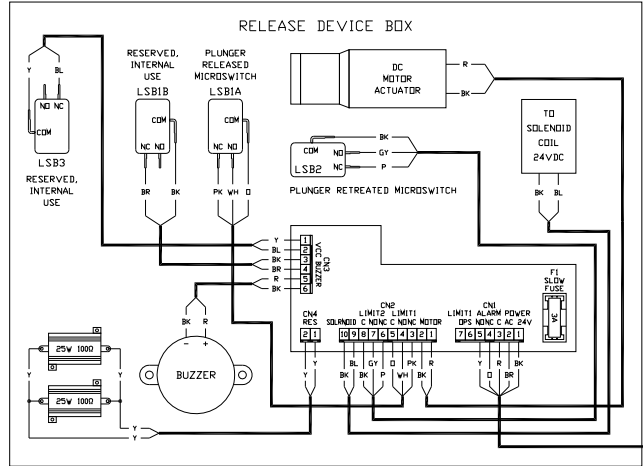
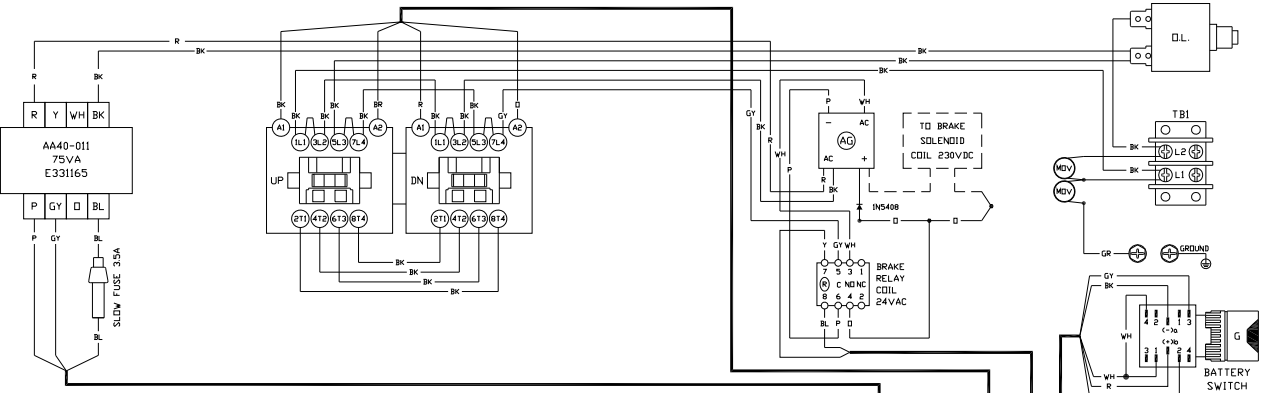

FSH 208V/230V 3 PHASE 50/60HZ LH (EP BOARD)
(FOR FSH-53EP, 73EP, 153EP)

EBH 304EP L
LW

- MAINBOARD PCB :
- EXTERNAL MODULE-MULTI FUNCTION SOCKET FOR OPTIONAL MODULE
 - SENSING DEVICE-SENSING MODULE CONNECTOR
 - SED-CLOSE CONTROL CONNECTOR
 - SEC-OPEN CONTROL CONNECTOR
 - POWER INDICATOR-SOCKET RJ11 FOR POWER INDICATOR CONNECTION
 - BATTERY SWITCH - BATTERY SWITCH CONNECTION
 - LOWBATT-LOW BATTERY STATUS DRY CONTACT OUTPUT SIGNAL
 - 18,19-EXTERNAL POWER INPUT 24VAC/DC
 - T2K-24VDC OUTPUT FOR T2000 MAGNETIC POWER.
 - AR-E-SIGNALS TO RELEASING DEVICE
 - TIMER POWER-JUMP FOR ENABLING RECLOSE TIMER
 - TH2-TEMPERATURE SENSOR
 - ALARM TEST-ALARM TEST JUMPER
 - BZ1-SOUND PATTERN REFER TO "F. SOUND WARNINGS" IN THE MANUAL.
 - F. DLY-FUSIBLE LINK DELAY 10 SEC.
 - A OPEN-AUTO OPEN AFTER ALARM CLEAR
 - (PRESS AND HOLD FOR 5 SEC. TO ACTIVATE)
 - A DLY-ALARM DELAY 10 SEC.
 - REV SS-REVERSE TO OPEN LIMIT OR REVERSE 5 SEC.
 - SELECT-EDGE/PHOTO EYE SENSING DEVICE SELECTION.
 - M CL-MOMENTARY/CONSTANT PRESSURE CLOSE
 - M DP-MOMENTARY/CONSTANT PRESSURE OPEN
 - REV TIMES-HIT & REVERSE CYCLES
 - T1 & T2-SEE INSTRUCTION MANUAL FOR DETAIL
 - JPA-DI NOT REMOVE, INTERNAL USE
 - JPB-OPEN AND CLOSE WARNING SIGNAL (JUMPED). REMOVE JUMPER FOR CLOSE WARNING SIGNAL ONLY.
 - JPC-RESERVED, INTERNAL USE
 - JPD-DI NOT REMOVE, INTERNAL USE
 - JPI0-BRAKE ENGAGE / DIS-ENGAGE AT CLOSE LIMIT POSITION.
 - JPI1-RESERVED, INTERNAL USE.

NOTE:
MEASURE THE LINE VOLTAGE TO BE USED AND CONNECT THE CORRESPONDING TRANSFORMER WIRE.
• IF 208V LINE VOLTAGE IS USED, CONNECT THE YELLOW TRANS WIRE
• IF 230V LINE VOLTAGE IS USED, CONNECT THE RED PWR WIRE TO THE RED TRANS WIRE.
• THE UNUSED WIRE SHOULD REMAIN INSULATED WITH THE CAP PROVIDED.
WARNING - FAILURE TO MAKE THE CORRECT TRANSFORMER CONNECTION FOR THE SUPPLIED LINE VOLTAGE WILL LEAD TO DAMAGE OF THE SYSTEM.

CONNECTOR PLUG
SEA ◀▶▶▶ SEC
SEB ◀▶▶▶ SED

- TERMINAL PCB - CN2 :
- CONTROL STATION-STOP
 - CONTROL STATION-OPEN
 - CONTROL STATION-CLOSE
 - CONTROL STATION-COMMN
 - MOVING WARNING SIGNAL 24VDC
 - 10810A-ALARM WARNING SIGNAL 24VDC
 - 11812-ALARM CONNECTION N/C DRY CONTACT
 - 31832 NON-MONITORED SENSING DEVICES (N/D DRY CONTACT)
 - E58E6/PSM6-EDGE/PHOTO EYES SENSING DEVICE CONNECTION
 - 36837 24VDC-POWER, MAX. 0.5A

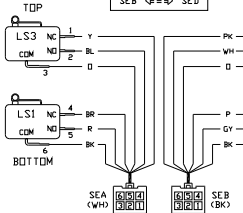

- NOTES :
- SEA-LS1 & LS3 MICROSWITCH CONNECTOR
 - SEB-LS2 & LS4 MICROSWITCH CONNECTOR

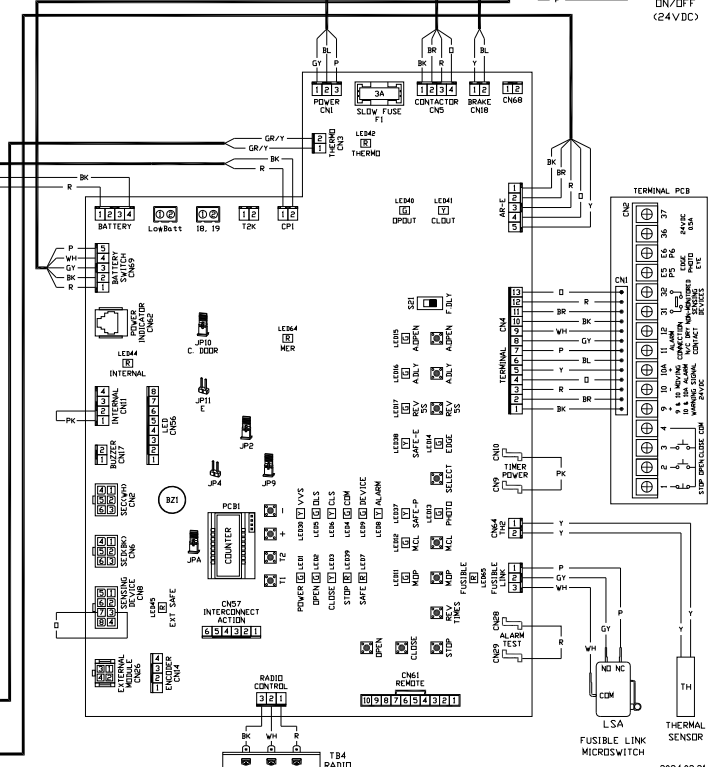
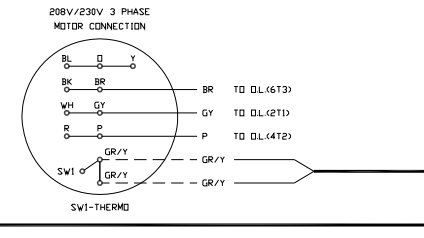
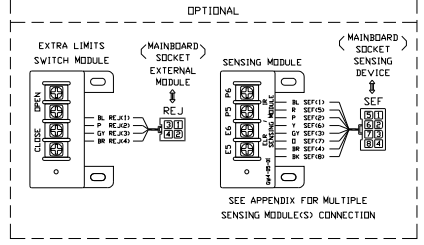
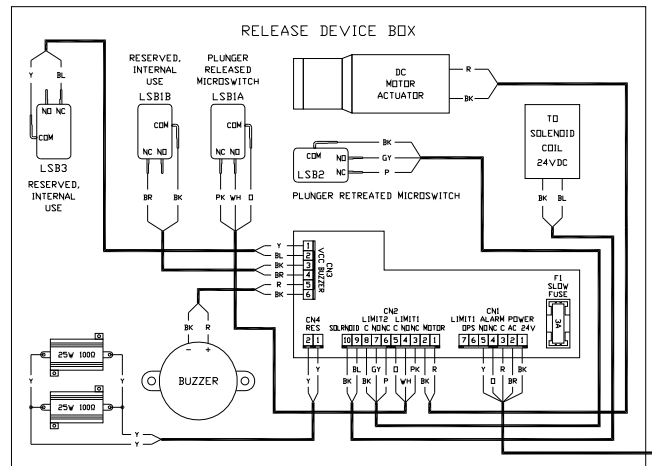
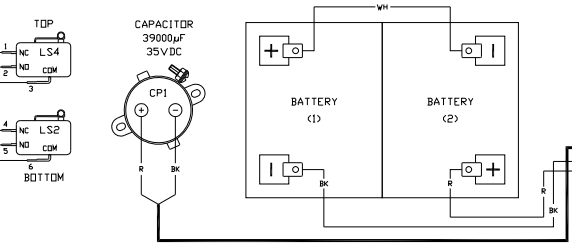
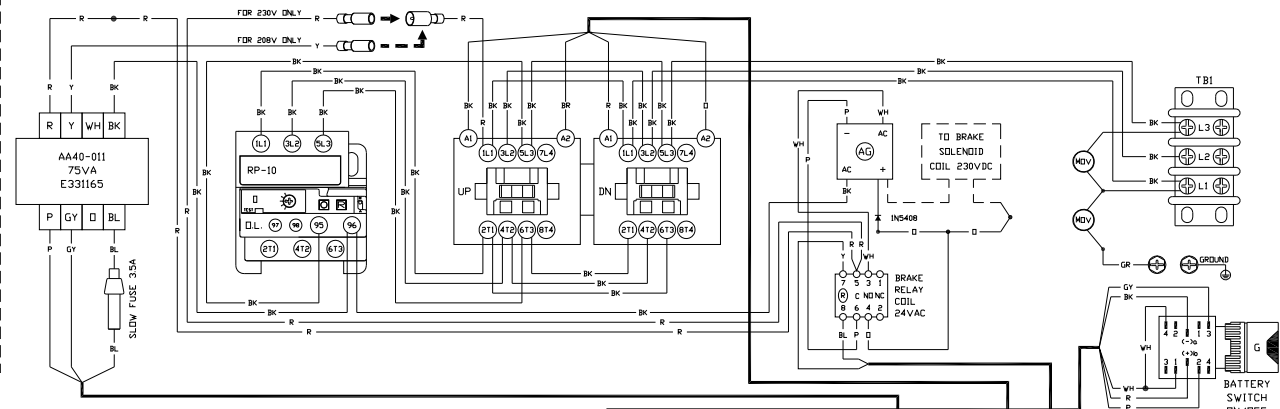

FSH 208V/230V 3 PHASE 50/60HZ RH (EP BOARD)
(FOR FSH-53EP, 73EP, 153EP)

EBH 304EP R
LW

MAINBOARD PCB

1. EXTERNAL MODULE-MULTI FUNCTION SOCKET FOR OPTIONAL MODULE
2. SENSING DEVICE-SENSING MODULE CONNECTOR
3. SEC-CLOSE CONTROL CONNECTOR
4. SEC-OPEN CONTROL CONNECTOR
5. POWER INDICATOR-SOCKET RJ11 FOR POWER INDICATOR CONNECTION
6. BATTERY SWITCH - BATTERY SWITCH CONNECTION
7. LOWBATT-LDW BATTERY STATUS DRY CONTACT OUTPUT SIGNAL
8. 18,19-EXTERNAL POWER INPUT 24VAC/DC
9. 12K-24VDC OUTPUT FOR T2000 MAGNETIC POWER
10. AR-E-SIGNALS TO RELEASING DEVICE
11. TIMER POWER-JUMP FOR ENABLING RECLOSE TIMER
12. TH2-TEMPERATURE SENSOR
13. ALARM TEST-ALARM TEST JUMPER
14. SZ1-SOUND PATTERN REFER TO "SOUND WARNINGS" IN THE MANUAL
15. F. DLY-FUSIBLE LINK DELAY 10 SEC
16. A. OPEN-AUTO OPEN AFTER ALARM CLEAR
(PRESS AND HOLD FOR 5 SEC. TO ACTIVATED)
17. A. DLY-ALARM DELAY 10 SEC
18. REV 5S-REVERSE TO OPEN LIMIT OR REVERSE 5 SEC.
19. SELECT-EDGE/PHOTO EYE SENSING DEVICE SELECTION
20. M. CL-MOMENTARY/CONSTANT PRESSURE CLOSE
21. M. OP-MOMENTARY/CONSTANT PRESSURE OPEN
22. REV TIMES-HIT & REVERSE CYCLES
23. T1 & T2-SEE INSTRUCTION MANUAL FOR DETAIL
24. JPA-DI NOT REMOVE, INTERNAL USE
25. JPB-OPEN AND CLOSE WARNING SIGNAL (JUMPED)
REMOVE JUMPER FOR CLOSE WARNING SIGNAL ONLY.
26. JPA-RESERVED, INTERNAL USE
27. JP9-DI NOT REMOVE, INTERNAL USE
28. JPI0-BRAKE ENGAGE / DIS-ENGAGE AT CLOSE LIMIT POSITION
29. JPI1-RESERVED, INTERNAL USE.

NOTE:
MEASURE THE LINE VOLTAGE TO BE USED AND CONNECT THE CORRESPONDING TRANSFORMER WIRE.
• IF 208V LINE VOLTAGE IS USED, CONNECT THE YELLOW TRANS WIRE.
• IF 230V LINE VOLTAGE IS USED, CONNECT THE RED PWR WIRE TO THE RED TRANS WIRE.
• THE UNUSED WIRE SHOULD REMAIN INSULATED WITH THE CAP PROVIDED.
WARNING! - FAILURE TO MAKE THE CORRECT TRANSFORMER CONNECTION FOR THE SUPPLIED LINE VOLTAGE WILL LEAD TO DAMAGE OF THE SYSTEM.

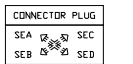

TERMINAL PCB - CN2

- 1-CONTROL STATION-STOP
 - 2-CONTROL STATION-OPEN
 - 3-CONTROL STATION-CLOSE
 - 4-CONTROL STATION-COMMON
 - 9&10-MOVING WARNING SIGNAL 24VDC
 - 10&10A-ALARM WARNING SIGNAL 24VDC
 - 11&12-ALARM CONNECTION N/C DRY CONTACT
 - 31&32 NON-MONITORED SENSING DEVICES
(N/C DRY CONTACT)
- ES&E6/P5&P6-EDGE/PHOTO EYES SENSING DEVICE CONNECTION
36&37 24VDC-POWER, MAX. 0.5A

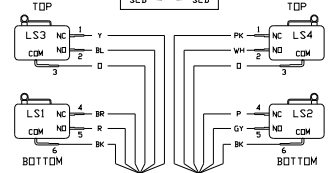

- NOTES:
1. SEA-LS1 & LS3 MICROSWITCH CONNECTOR
2. SEB-LS2 & LS4 MICROSWITCH CONNECTOR

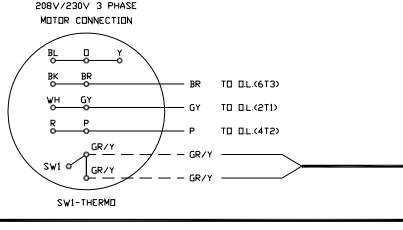
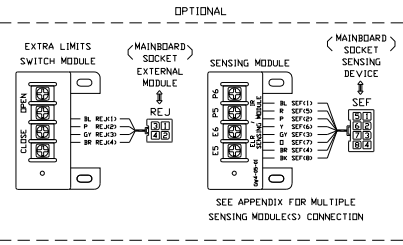
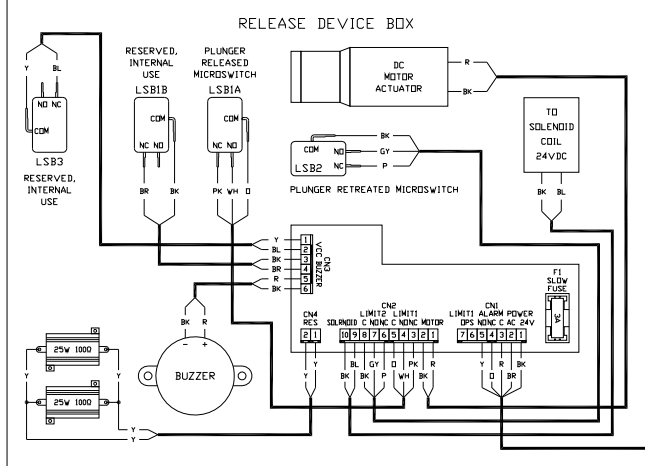
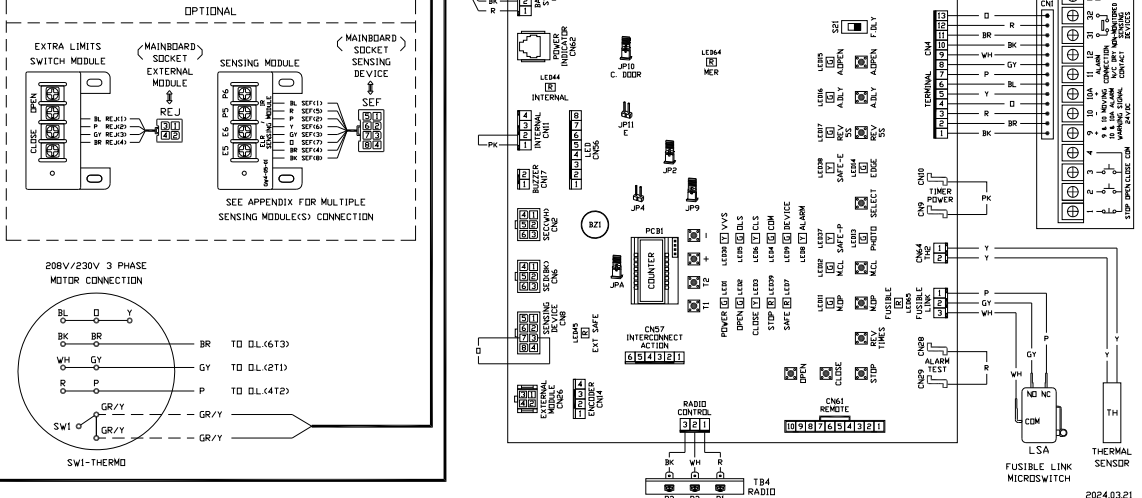
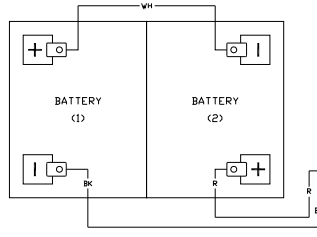
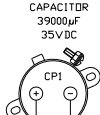
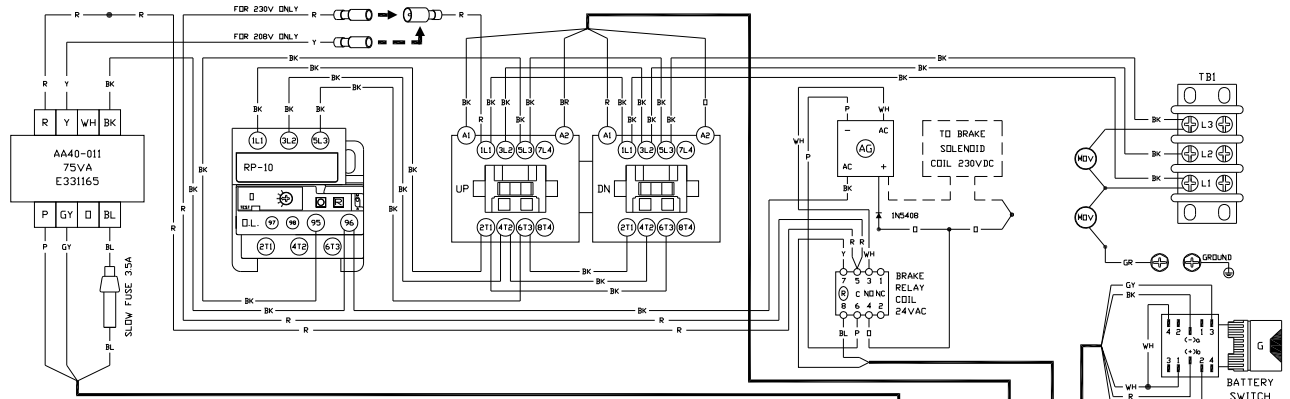

FSH 460V 3 PHASE 50/60HZ RH (EP BOARD)
(FOR FSH-54EP, 74EP, 154EP)

EBH 404EP R

MAINBOARD PCB :

1. EXTERNAL MODULE-MULTI FUNCTION SOCKET FOR OPTIONAL MODULE
2. SENSING DEVICE-SENSING MODULE CONNECTOR
3. SEB-CLOSE CONTROL CONNECTOR
4. SEC-OPEN CONTROL CONNECTOR
5. POWER INDICATOR-SOCKET RJ11 FOR POWER INDICATOR CONNECTION.
6. BATTERY SWITCH - BATTERY SWITCH CONNECTION.
7. LOWBATT-LOW BATTERY STATUS DRY CONTACT OUTPUT SIGNAL.
8. 18.19-EXTERNAL POWER INPUT 24VAC/DC
9. 12K-24VDC OUTPUT FOR T2000 MAGNETIC POWER.
10. AR-E-SIGNALS TO RELEASING DEVICE
11. TIMER POWER-JUMP FOR ENABLING RECLOSE TIMER
12. TH2-TEMPERATURE SENSOR
13. ALARM TEST-ALARM TEST JUMPER
14. BZ1-SDIAD PATTERN REFER TO "SOUND WARNINGS" IN THE MANUAL.
15. F. DLY-FUSIBLE LINK DELAY 10 SEC.
16. A. OPEN-AUTO OPEN AFTER ALARM CLEAR
(PRESS AND HOLD FOR 5 SEC. TO ACTIVATED)
17. A. DLY-ALARM DELAY 10 SEC.
18. REV 5S-REVERSE TO OPEN LIMIT OR REVERSE 5 SEC.
19. SELECT-EDGE/PHOTO EYE SENSING DEVICE SELECTION.
20. M. CL-MOMENTARY/CONSTANT PRESSURE CLOSE
21. M. OP-MOMENTARY/CONSTANT PRESSURE OPEN
22. REV. TIMES-HIT & REVERSE CYCLES
23. T1 & T2-SEC INSTRUCTION MANUAL FOR DETAIL
24. JPA-DO NOT REMOVE, INTERNAL USE
25. JP2-OPEN AND CLOSE WARNING SIGNAL (JUMPED).
REMOVE JUMPER FOR CLOSE WARNING SIGNAL ONLY.
26. JP4-RESERVED, INTERNAL USE.
27. JP9-DO NOT REMOVE, INTERNAL USE
28. JP10-BRAKE ENGAGE / DIS-ENGAGE AT CLOSE LIMIT POSITION.
29. JP11-RESERVED, INTERNAL USE.

TERMINAL PCB - CN2 :

- 1-CONTROL STATION-STOP
- 2-CONTROL STATION-OPEN
- 3-CONTROL STATION-CLOSE
- 4-CONTROL STATION-COMMON
- 9B10-MOVING WARNING SIGNAL 24VDC
- 10K10A-ALARM WARNING SIGNAL 24VDC
- 11K12-ALARM CONNECTION N/C DRY CONTACT
- 31K32 NON-MONITORED SENSING DEVICES
(N/D DRY CONTACT)
- E5K6/P5K6-EDGE/PHOTO EYES SENSING
DEVICE CONNECTION
- 36K37 24VDC-POWER, MAX. 0.5A

- NOTES :
1. SEA-LS1 & LS3 MICROSWITCH CONNECTOR
 2. SEB-LS2 & LS4 MICROSWITCH CONNECTOR

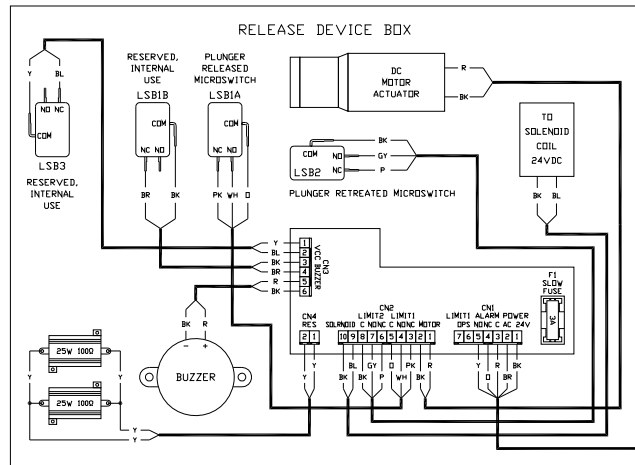

CAPACITOR
39000µF
35VDC
CPI

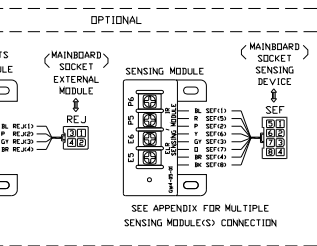

460V 3 PHASE
MOTOR CONNECTION

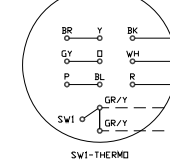

SW1-THERMID

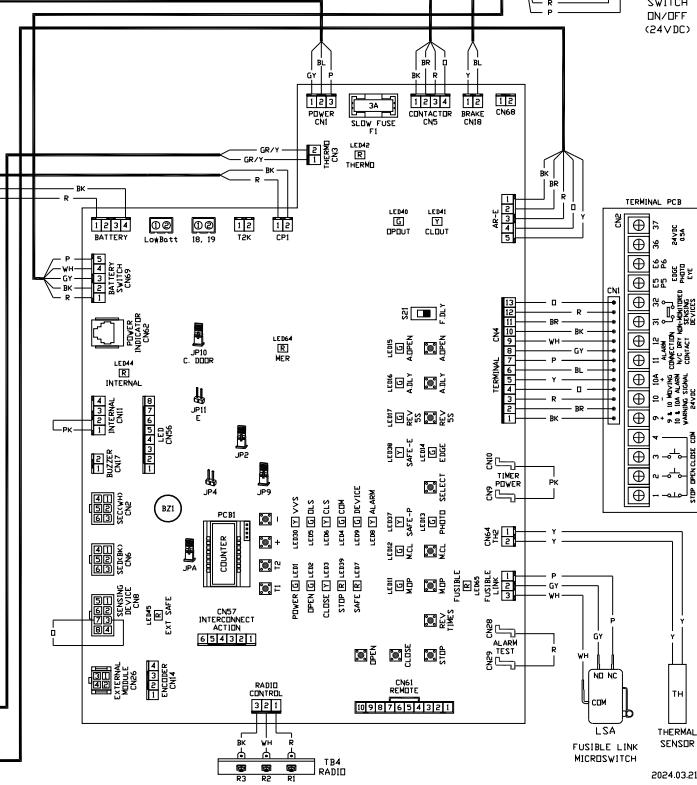
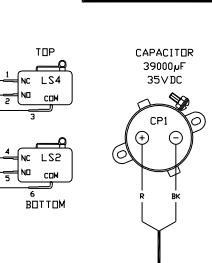
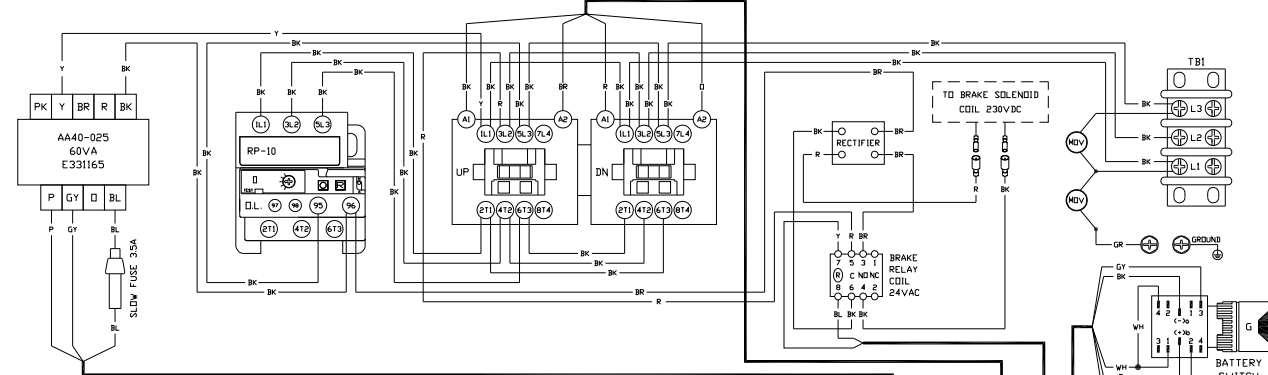

FSH 575V 3 PHASE 60HZ LH (EP BOARD)
(FOR FSH-58EP, 78EP, 158EP)

EBH 604EP L

MAINBOARD PCB :

- EXTERNAL MODULE-MULTI FUNCTION SOCKET FOR OPTIONAL MODULE
 - SENSING DEVICE-SENSING MODULE CONNECTOR
 - SEC-CLOSE CONTROL CONNECTOR
 - SEC-OPEN CONTROL CONNECTOR
 - POWER INDICATOR-SOCKET RJ11 FOR POWER INDICATOR CONNECTION
 - BATTERY SWITCH - BATTERY SWITCH CONNECTION
 - LOWBATT-LOW BATTERY STATUS DRY CONTACT OUTPUT SIGNAL
 - 1919-EXTERNAL POWER INPUT 24VAC/DC
 - T2K-24VDC OUTPUT FOR 12000 MAGNETIC POWDER
 - AR-E-SIGNALS TO RELEASING DEVICE
 - TIMER POWER-JUMP FOR ENABLING RECLOSE TIMER
 - TH2-TEMPERATURE SENSOR
 - ALARM TEST-ALARM TEST JUMPER
 - BZ1-SOUND PATTERN REFER TO 'F. SOUND WARNINGS' IN THE MANUAL
 - F. DLY-FUSIBLE LINK DELAY 10 SEC.
 - A. OPEN-AUTO OPEN AFTER ALARM CLEAR
- (PRESS AND HOLD FOR 5 SEC. TO ACTIVATE)
- A. DLY-ALARM DELAY 10 SEC.
 - REV SS-REVERSE TO OPEN LIMIT OR REVERSE 5 SEC.
 - SELECT-EDGE/PHOTO EYE SENSING DEVICE SELECTION
 - M. CL-MOMENTARY/CONSTANT PRESSURE CLOSE
 - M. OP-MOMENTARY/CONSTANT PRESSURE OPEN
 - REV TIMES-HIT & REVERSE CYCLES
 - T1 & T2-SEE INSTRUCTION MANUAL FOR DETAIL
 - JP4-DD NOT REMOVE, INTERNAL USE
 - JP2-OPEN AND CLOSE WARNING SIGNAL (JUMPED): REMOVE JUMPER FOR CLOSE WARNING SIGNAL ONLY.
 - JP4-RESERVED, INTERNAL USE.
 - JP9-DD NOT REMOVE, INTERNAL USE
 - JP10-BRAKE ENGAGE / DIS-ENGAGE AT CLOSE LIMIT POSITION
 - JP11-RESERVED, INTERNAL USE.

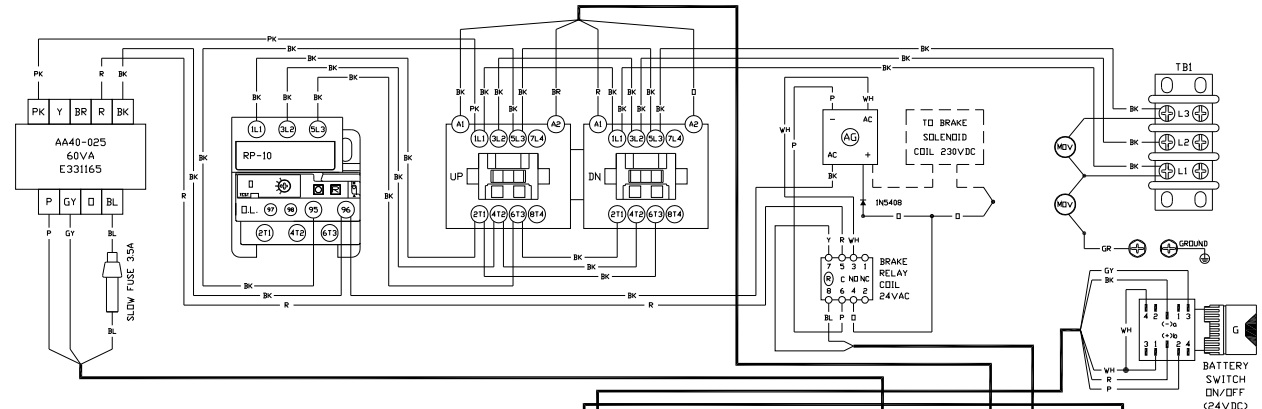

TERMINAL PCB - CN2 :

- CONTROL STATION-STOP
 - CONTROL STATION-OPEN
 - CONTROL STATION-CLOSE
 - CONTROL STATION-COMMON
 - MOVING WARNING SIGNAL 24VDC
 - ALARM WARNING SIGNAL 24VDC
 - ALARM CONNECTION N/C DRY CONTACT
 - NON-MONITORED SENSING DEVICES (N/O DRY CONTACT)
- E5K6/PS6P6-EDGE/PHOTO EYES SENSING DEVICE CONNECTION
- 36837 24VDC-POWER, MAX. 0.5A

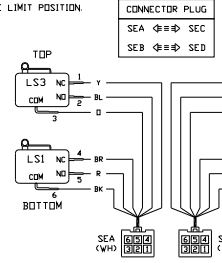

- NOTES :
- SEA-LS1 & LS3 MICROSWITCH CONNECTOR
 - SEB-LS2 & LS4 MICROSWITCH CONNECTOR

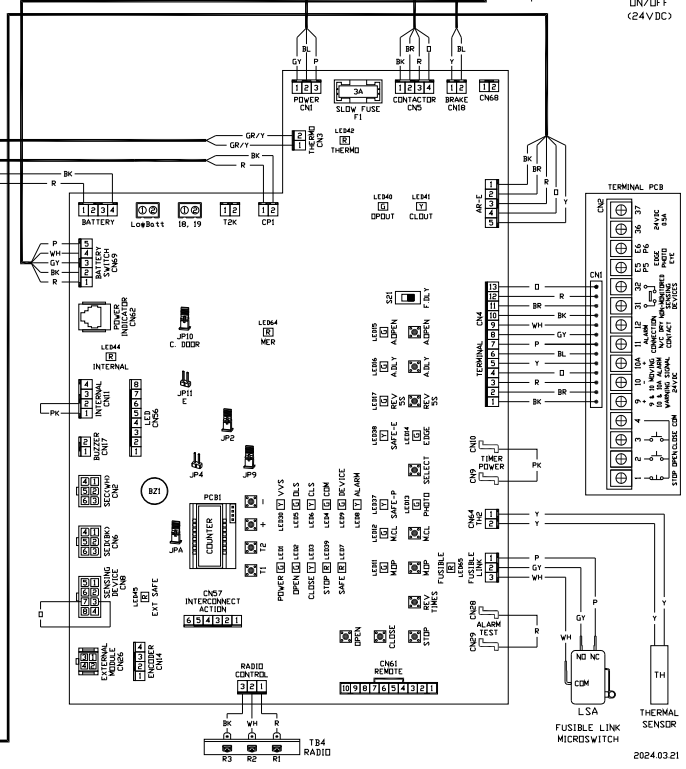
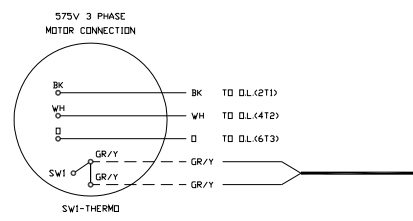
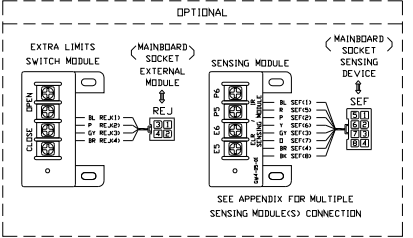
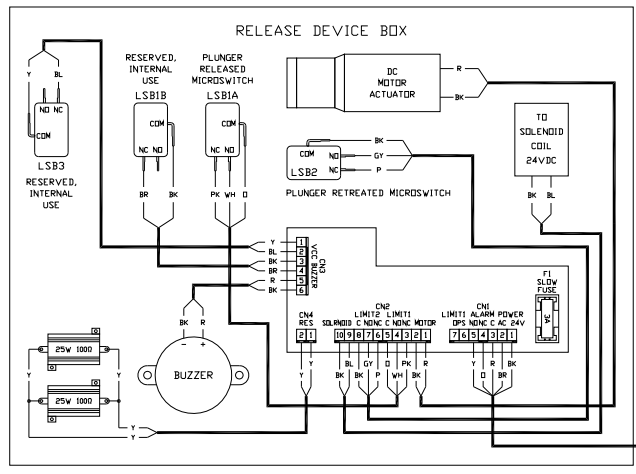

2024.03.21

FSH 575V 3 PHASE 60HZ RH (EP BOARD)
(FOR FSH-58EP, 78EP, 158EP)

EBH 604EP R

MAINBOARD PCB :

- EXTERNAL MODULE-MULTI FUNCTION SOCKET FOR OPTIONAL MODULE
- SENSING DEVICE-SENSING MODULE CONNECTOR
- SEC-CLOSE CONTROL CONNECTOR
- SEC-OPEN CONTROL CONNECTOR
- POWER INDICATOR-SOCKET RJ11 FOR POWER INDICATOR CONNECTION
- BATTERY SWITCH - BATTERY CONNECTION
- LOW-BATT-LOW BATTERY STATUS DRY CONTACT OUTPUT SIGNAL
- 18.19-EXTERNAL POWER INPUT 24VAC/DC
- TK2-24VDC OUTPUT FOR T2000 MAGNETIC POWER
- AR-E-SIGNALS TO RELEASING DEVICE
- TIMER POWER-JUMP FOR ENABLING RECLOSE TIMER
- TH2-TEMPERATURE SENSOR
- ALARM TEST-ALARM TEST JUMPER
- BZ1-SOUND PATTERN REFER TO "F. SOUND WARNINGS" IN THE MANUAL
- F. DLY-FUSIBLE LINK DELAY 10 SEC.
- A. OPEN-AUTO OPEN AFTER ALARM CLEAR (PRESS AND HOLD FOR 5 SEC. TO ACTIVATE)
- A. DLY-ALARM DELAY 10 SEC.
- REV 5S-REVERSE TO OPEN LIMIT DR REVERSE 5 SEC.
- SELECT-EDGE/PHOTO EYE SENSING DEVICE SELECTION
- M. CL-MOMENTARY/CONSTANT PRESSURE CLOSE
- M. DP-MOMENTARY/CONSTANT PRESSURE OPEN
- REV TIMES-HIT & REVERSE CYCLES
- T1 & T2-SEC INSTRUCTION MANUAL FOR DETAIL
- JPA-DI NOT REMOVE, INTERNAL USE
- JP2-OPEN AND CLOSE WARNING SIGNAL (JUMPED). REMOVE JUMPER FOR CLOSE WARNING SIGNAL ONLY.
- JP4-RESERVED, INTERNAL USE
- JP9-DI NOT REMOVE, INTERNAL USE
- JP10-BRAKE ENGAGE / DIS-ENGAGE AT CLOSE LIMIT POSITION
- JP11-RESERVED, INTERNAL USE

TERMINAL PCB - CN2 :

- CONTROL STATION-STOP
 - CONTROL STATION-OPEN
 - CONTROL STATION-CLOSE
 - CONTROL STATION-COMMON
 - 9810-MOVING WARNING SIGNAL 24VDC
 - 10810A-ALARM WARNING SIGNAL 24VDC
 - 11812-ALARM CONNECTION N/C DRY CONTACT
 - 31832 NDN-MONITORED SENSING DEVICES (N/D DRY CONTACT)
- ES8E6/PS8P6-EDGE/PHOTO EYES SENSING DEVICE CONNECTION
36637 24VDC-POWER, MAX. 0.5A

- NOTES :
- SEA-LS1 & LS3 MICROSWITCH CONNECTOR
 - SEB-LS2 & LS4 MICROSWITCH CONNECTOR

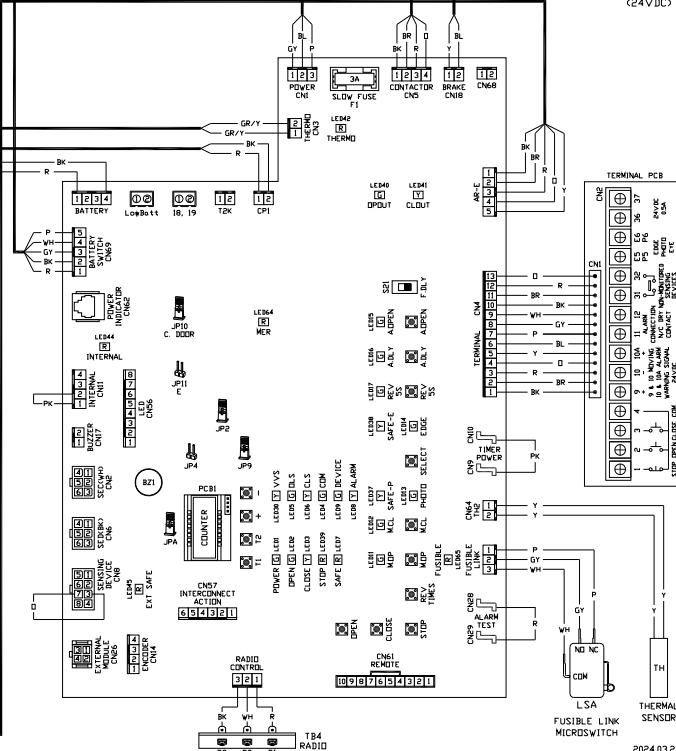
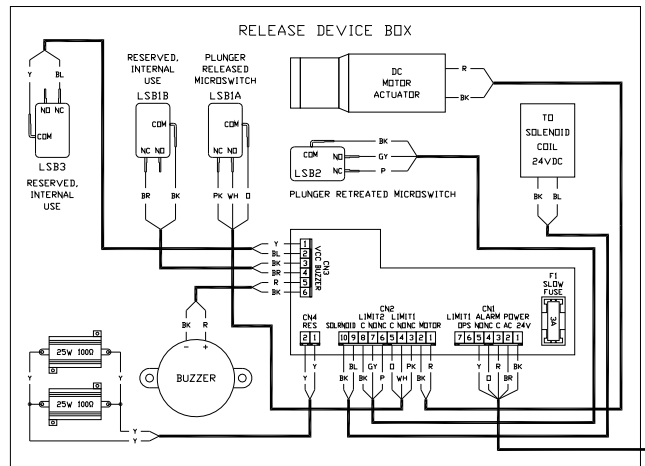
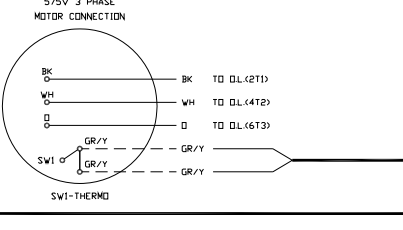
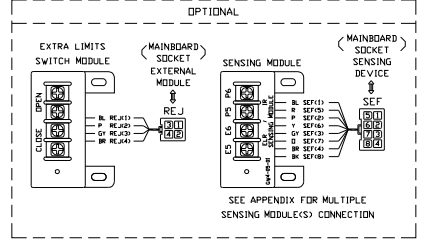
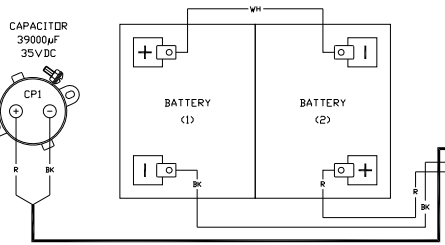
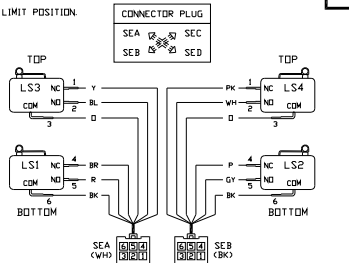
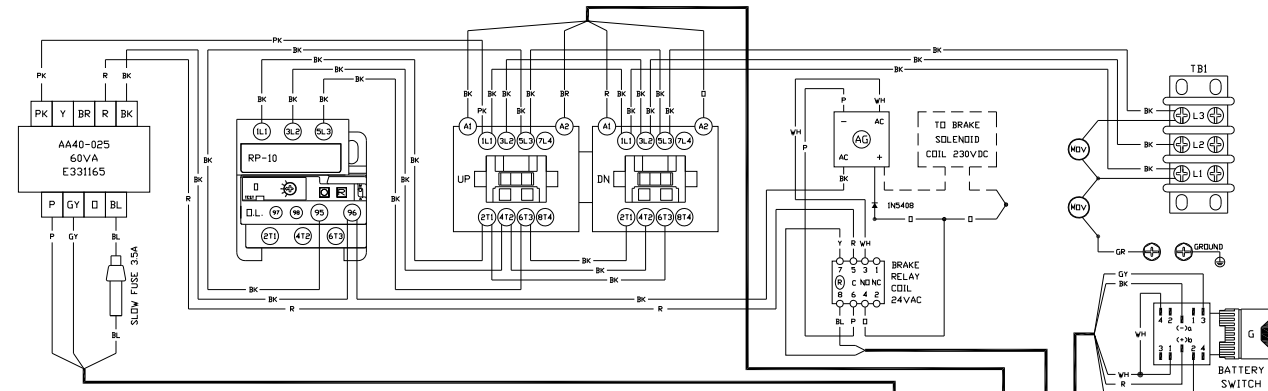

IMPORTANT SAFETY INSTRUCTIONS

WARNING –To reduce the risk of death or serious injury:

1. READ AND FOLLOW ALL INSTRUCTIONS.
2. Never let children operate or play with door controls. Keep the remote control (when provided) away from children.
3. Personnel should keep away from a door in motion and keep the moving door in sight until it is completely closed or opened. NO ONE SHOULD CROSS THE PATH OF A MOVING DOOR.



Fire doors could close rapidly at any time and cause death or serious injury.

WARNING

Do NOT stand in the doorway.

4. Test sensing devices at least once a month. Also test sensing devices after making any adjustments to the close limit. Failure to adjust the operator properly may cause death or serious injury.
5. For operators having an auxiliary release, use caution when using the release if the door is open. Weak or broken springs may cause the door to fall rapidly, causing death or serious injury.
6. KEEP DOORS PROPERLY OPERATING AND BALANCED. See door manufacturer's Operation and Maintenance Instructions. An improperly operating or unbalanced door could cause death or serious injury. Have trained door systems technicians make all necessary adjustments and repairs.
7. **SAVE THESE INSTRUCTIONS.**

FUSIBLE LINK CONNECTIONS

- ❖ **REMOVE COTTER PIN FROM RELEASE ASSEMBLY AFTER INSTALLATION IS COMPLETE.**

Refer to the fire door installation instructions for connection of the release assembly or consult NFPA-80 and the authority having jurisdiction for fusible link location(s) and method.

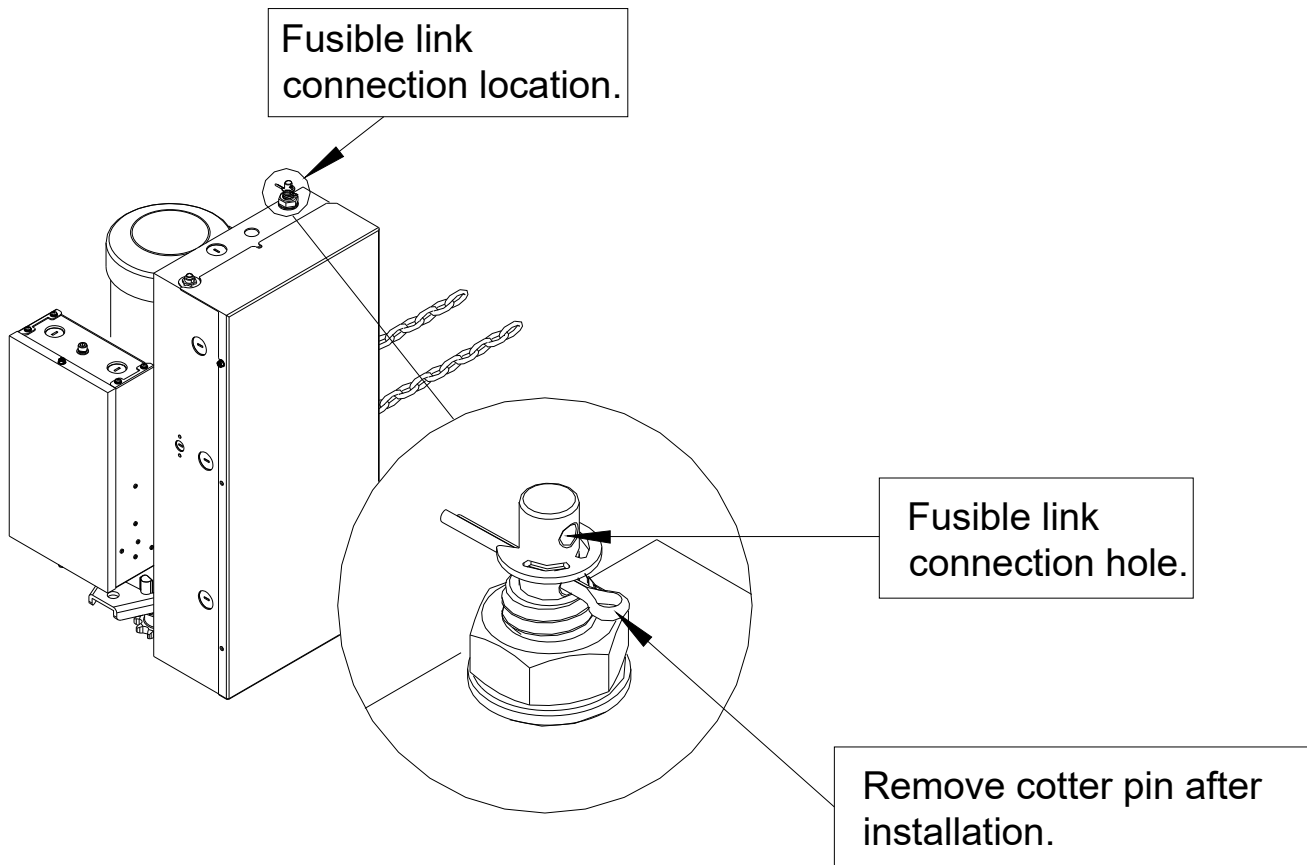

* Illustration only, not drawn to scale. See product for actual details.

OPERATING INSTRUCTIONS

1. If a 3-button control station is used to operate the door, push the “OPEN” button to open the door, push the “CLOSE” button to close the door, push the “STOP” button to stop movement of the door while opening or closing. With constant pressure close operation, removing pressure from the “CLOSE” button will also cause the door to stop.
2. If a key switch control station is used to operate the door, turn the key to the “OPEN” position to open the door, turn the key to the “CLOSE” position to close the door, push the “STOP” button to stop movement of the door while opening or closing. With constant pressure close operation, removing pressure from the “CLOSE” key position will cause the door to stop.
3. Door may also be operated by remote devices.

IMPORTANT NOTE: If one or more monitored sensing devices are installed, and determined by the operator to be not functioning properly, the door will either stay open, or re-open if closing. If this occurs, contact a trained door systems technician to make repairs. Until repairs can be made, the door can be opened and closed from the 3-button or key switch control station, but will require constant pressure on the close control to close the door.

EMERGENCY MANUAL OPERATION

This operator has provisions for manually operating the door in case of emergency or power failure. This operator is equipped with an auxiliary chain hoist.

To operate the auxiliary chain hoist:

1. Remove the hand chain from the chain bag.
 2. Pull the hand chain to operate the door in the desired direction. (No clutch to engage)
- Put the hand chain back into the chain bag, before operating the door again electrically.



WARNING

Turn off power to the operator before manually operating your door.



WARNING

Hand chain must be kept inside chain bag when operating electrically.

MAINTENANCE INSTRUCTIONS

The brake is a self-adjusting brake. It is maintenance free. The brake assembly requires no additional adjustments for its lifetime.

If an entrapment protection device is used, i.e. sensing edge or photoelectric sensors, please consult the manufacturer for maintenance instruction.



Disconnect power supply to the operator before servicing.

WARNING

Check the following items at the intervals listed:

CHECK LIST	DESCRIPTION	EVERY 3 MONTHS	EVERY 6 MONTHS	EVERY 12 MONTHS
Drive Chain	Check for excessive slack. Check & adjust as required Lubricate.	●		
Sprockets	Check set screw tightness	●		
Fasteners	Check & tighten as required		●	
Bearings & Shafts	Check for wear & lubricate	●		
Drop-test	Inspect door, drop-test for proper operation and full closure per NFPA-80			●
Battery	Check battery voltage must higher than 11.5VDC		●	

- ❖ Do not lubricate motor. Motor bearings are rated for continuous operation.
- ❖ Inspect and service whenever a malfunction either door or operator is observed or suspected.
- ❖ Before servicing, always disconnect power supply to the operator.
- ❖ Replace fuses only with those of the same type and rating.
- ❖ All replacement parts must be obtained from the door manufacturer per NFPA-80.
- ❖ Battery changes every 2 years or fail to charge whichever comes first. The change procedure describe in battery specification and connection



WARNING

Do not place hands or tools in or near the operator when the power is connected or when testing control or sensing devices. Always disconnect power before servicing or adjusting the operator.

APPENDIX 1

ELR / IR Combo Module Kit Instruction for FSH EP

Warning : Power OFF When Connecting.

INST-GDAAT-0AMA-X001 -V02

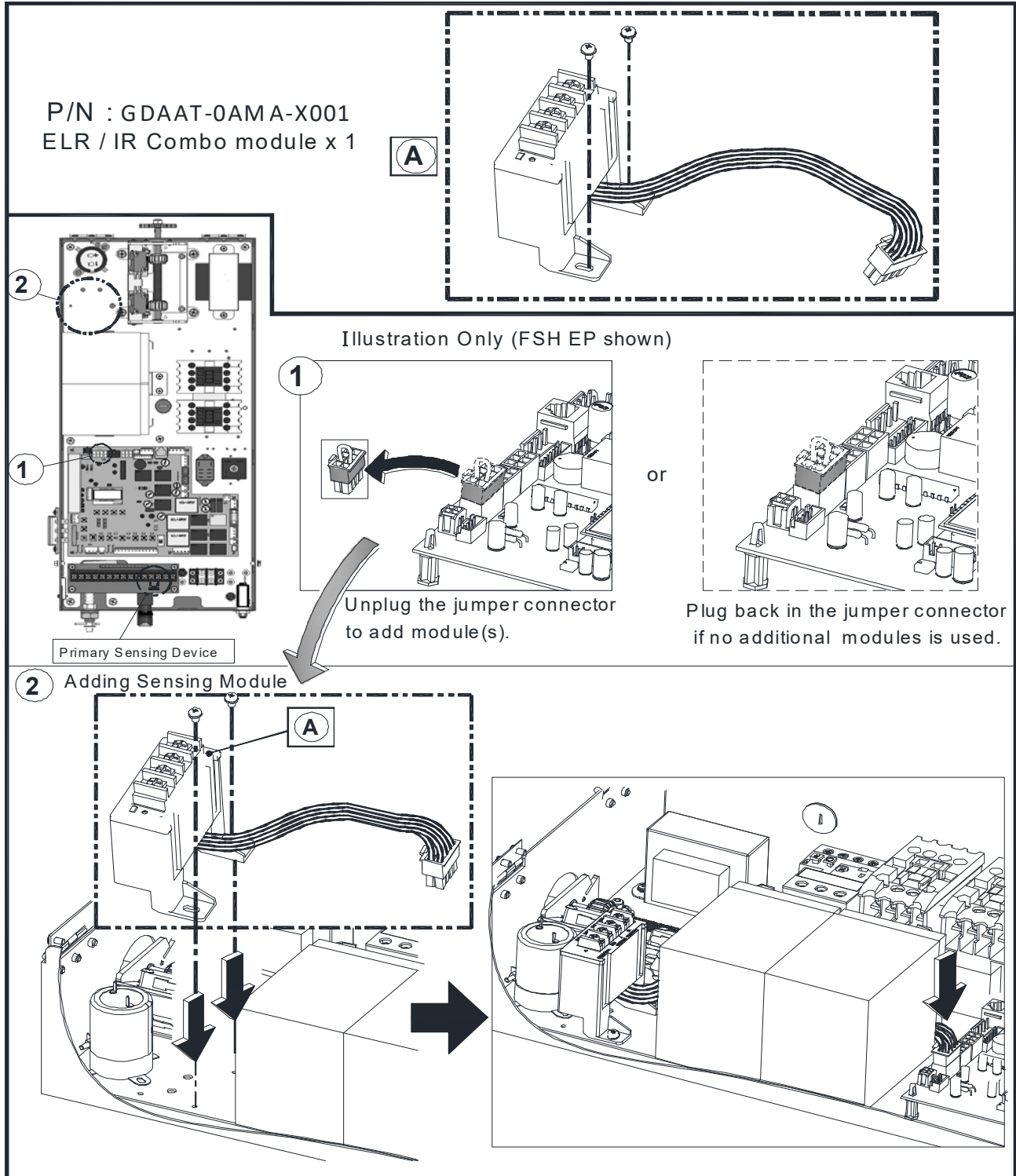

APPENDIX 2

Control Connections Diagrams

CCD-PCB-A01

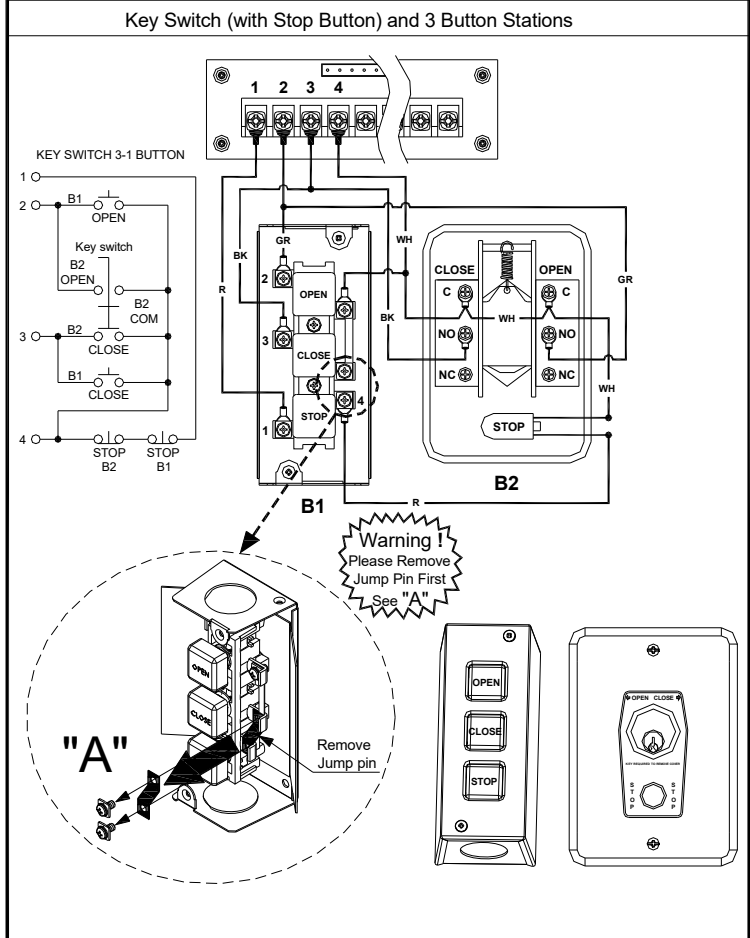
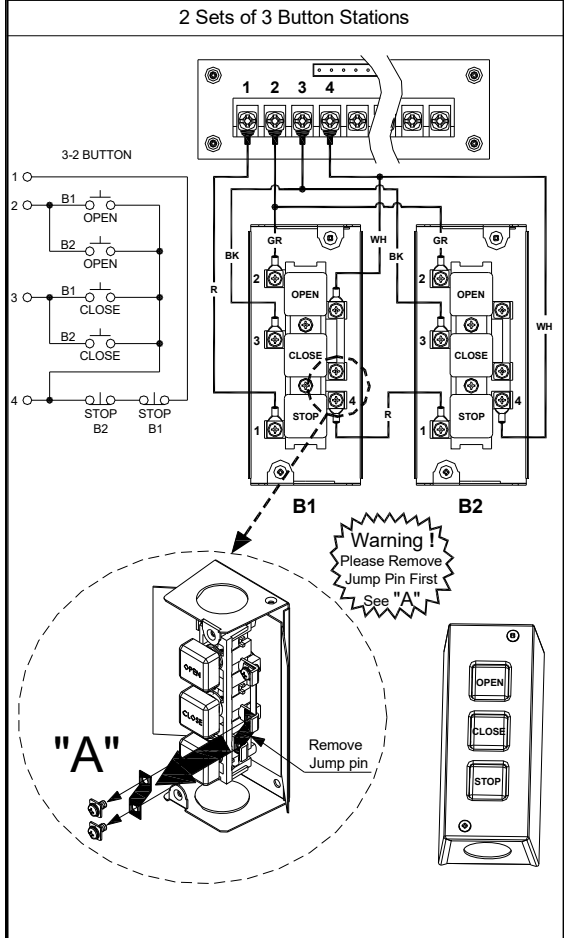
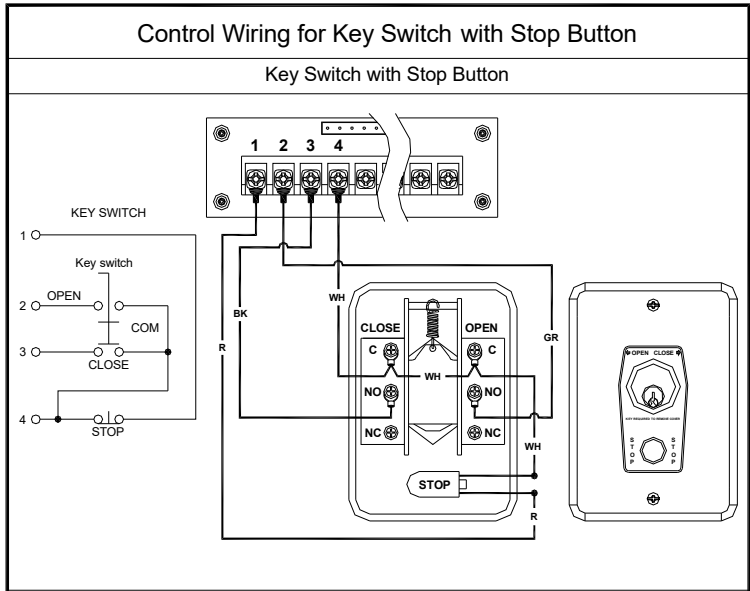
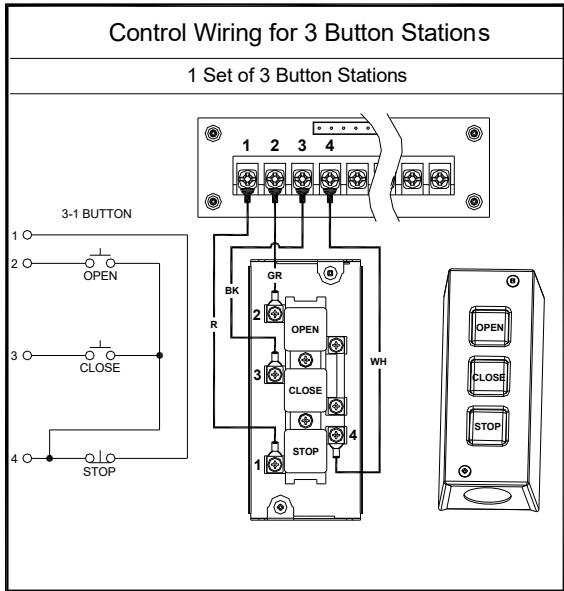

APPENDIX 3

Control Connections Diagrams

CCD-PCB-B02

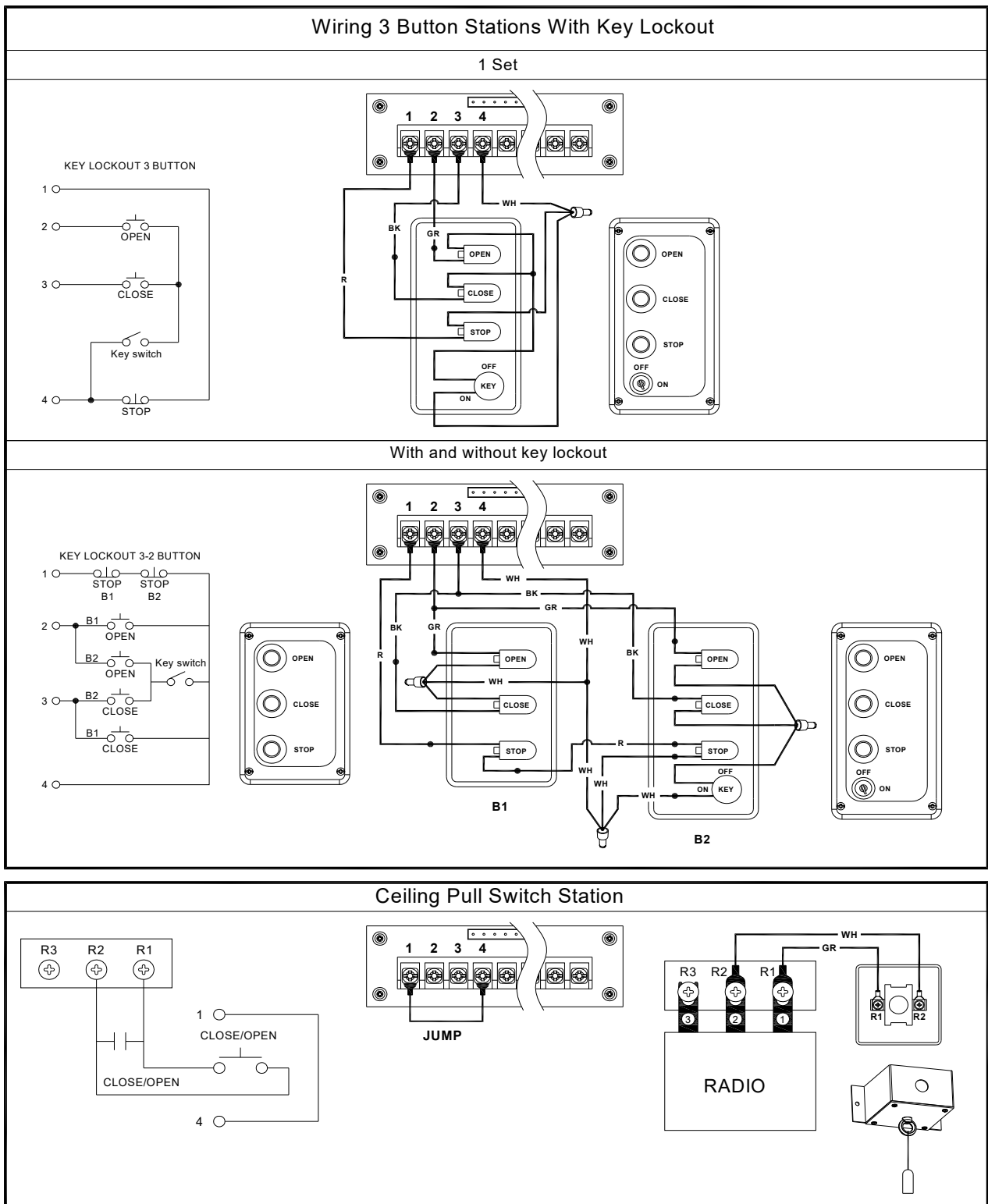

APPENDIX 4

EXTERNAL TIMER DEFEAT SWITCH CONNECTION-EP BOARD

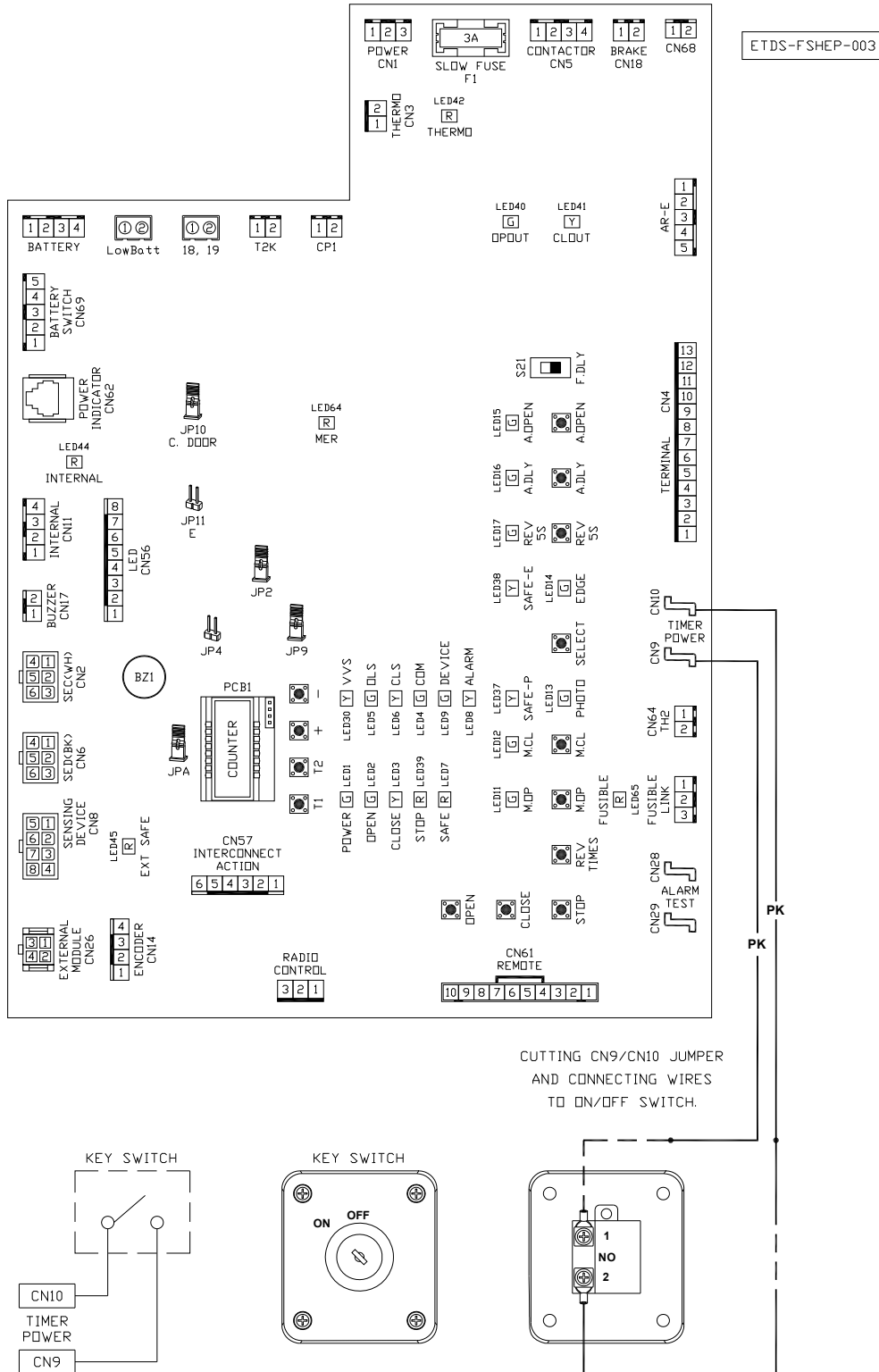

APPENDIX 5

Transformer Wiring Instruction for 208V/230V 3 Phase Operator EGH & FSH EP Series

EGH-EP-3P-LW-V01

Measure the line voltage to be used and connect the corresponding transformer wire.

- If 208V line voltage is used, connect the Red PWR Wire to the Yellow TRANS Wire.
- If 230V line voltage is used, connect the Red PWR Wire to the Red TRANS Wire.
- The unused wire should remain insulated with the cap provided.

WARNING! - Failure to make the correct transformer connection for the supplied line voltage will lead to damage of the system.

