

NOTES:

1. Left hand operation as shown. Right hand operation is opposite.
2. Elevation and section shown are for typical face mount doors.
3. Control panel can be moved to suit field conditions.

GUIDE DETAILS

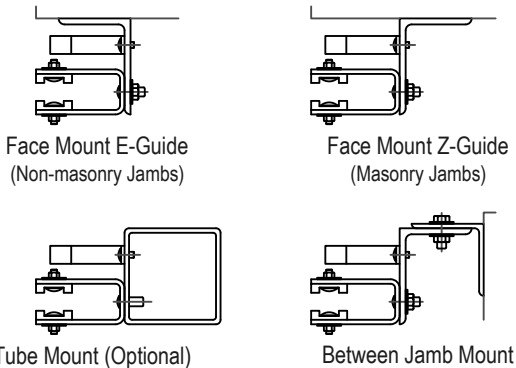

CURTAIN & BOTTOM BAR DETAILS

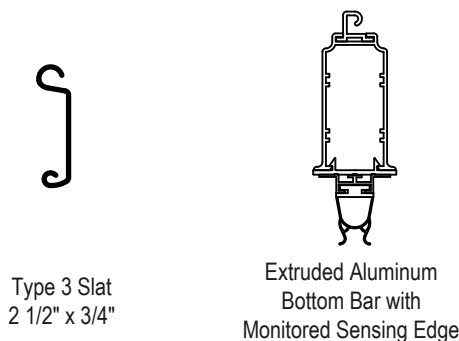

CLEARANCES

	TS	MS	B	L
Non-shaded area	8"	8"	18"	24"
Shaded area	8"	12"	22"	36"

Consult factory for Tube Mount dimensions.

TYPE 3 ALUMINUM SLAT

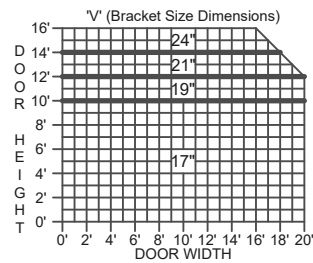

TYPE 3 STEEL SLAT

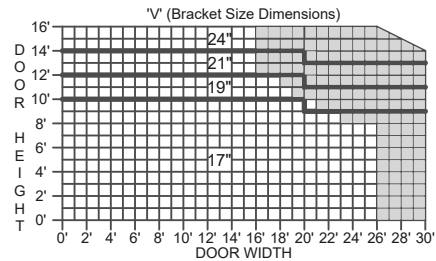

GENERAL NOTES:

Clearances are based upon standard door construction. Some options may require additional clearance. Shop drawings for specific applications are available. Consult factory for larger doors and any information not shown.