

EXPE

Explosion-Proof Photoeye

Installation Instructions



Designed for explosive environments, the rugged EXPE thru beam photoeye is used as a safety, reversing or opening device with automatic gate and door operators. The photoeye provides a signal to the operator that the beam is or is not obstructed. The EXPE operates up to 115 feet in a cast aluminum housing. A red alignment indicator on the receiver provides status information at a glance, making set-up and alignment easy.

Cautions and Warnings



This product is an accessory or part of a system. Install the EXPE according to instructions from the door operator manufacturer. Comply with all applicable codes and safety regulations.

Specifications

Operating Range	Up to 115 ft. (35 m)
Power	12-24 VDC/AC
Current Draw of Transmitter	37 mA
Current Draw of Receiver	23 mA standby, 17 mA detect
Surge Protection	Thermal fuse
Relay Output Configuration	Form C contacts (NO, COM, NC)
Relay Contact Rating	1 A at 24 VDC / 120 VAC
Operating Temperature	-40° to 170°F (-40° to 77°C)
Housing Material	Cast aluminum
Dimensions (L x W x H)	3.4" (87 mm) x 4.5" (114 mm) x 4.7" (119 mm)
Environmental Rating	NEMA 4 & 7, NEC Class 1 Groups B, C, & D, NEC Class II Groups E, F & G, CSA CENELEC, EExd IIC

Board Diagram

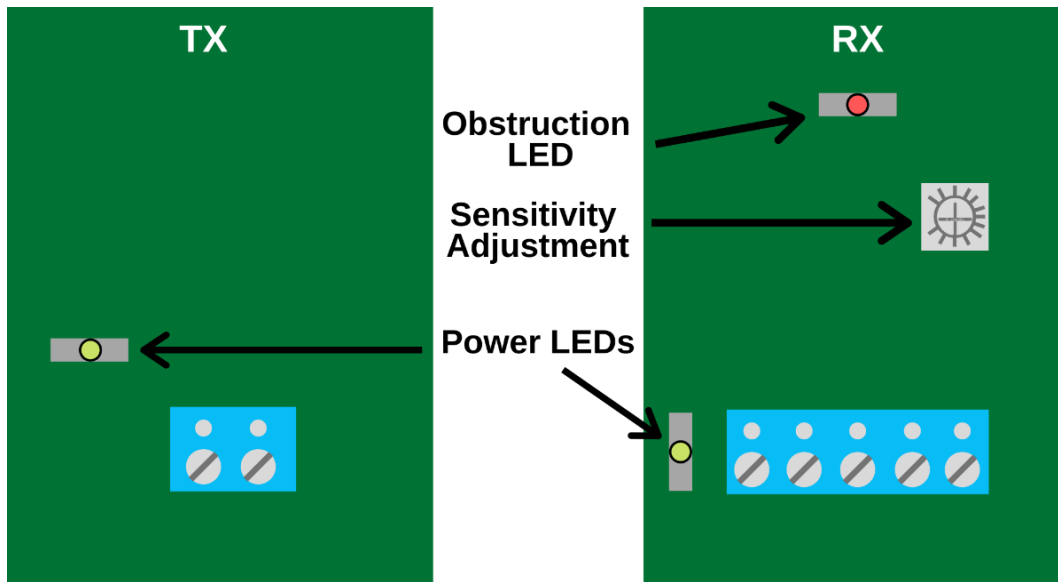

Installation

1. Remove the plastic and threaded plugs from both sides of the housing. Determine which direction the conduit will enter the housing and insert the threaded plug on the opposite side.
2. Connect 12-24 VDC/AC power to the "Power Input" terminals on the transmitter (marked "TX") and receiver (marked "RX"). The power input terminals are not polarity sensitive.
3. Connect the Common (COM) to the control input terminal per the operator manufacturer.
4. Connect either the Normally Open (NO) or Normally Closed (NC) as needed to the control input terminal per the operator manufacturer.
5. Adjust the sensitivity potentiometer as needed by turning counter clockwise to increase gain. Use the minimum sensitivity setting needed to achieve reliable detection.
6. Verify that the EXPE transmitter and receiver are aligned and apply power.

LED Indicators	
Green transmitter LED on	Power
Green receiver LED on	Power
Red receiver LED on	Beam blocked or not aligned

7. Place an obstruction (ex. hand) between the EXPE transmitter and receiver. The red LED on the receiver will turn on. Check the operator control board and verify that the safety input is recognized by the operator. Test the beam with an obstruction between the transmitter and receiver at multiple distances to confirm proper operation.
8. Remove the obstruction and red LED will turn off.



- If EXPE is aligned but not detecting an obstruction, consider slowly reducing the sensitivity (clockwise) on the receiver until the obstruction is detected. This may be applicable for installations with a detection zone of less than 20 ft.

Troubleshooting

Symptom	Possible Cause	Solution
Does not detect obstruction	Sensitivity is too high Signal is reflecting off another surface	Decrease sensitivity potentiometer clockwise. Check area for highly reflective surfaces.
Receiver red LED on continuously, indicating an obstruction when one is not present	Sensitivity is too low Transmitter does not have power Receiver does not "see" transmitter	Increase sensitivity potentiometer counter-clockwise. Check power source of transmitter. Make sure transmitter and receiver are aligned.
Receiver activates but does not transmit signal to operator	Faulty connection between receiver and operator control input	Verify all wires and terminal connections.